



Scottish Health Technical Memorandum 2010

(Part 2 of 6)

Design considerations

Sterilization

Disclaimer

The contents of this document are provided by way of guidance only. Any party making any use thereof or placing any reliance thereon shall do so only upon exercise of that party's own judgement as to the adequacy of the contents in the particular circumstances of its use and application. No warranty is given as to the accuracy of the contents and the Property and Environment Forum Executive, which produced this document on behalf of NHSScotland Property and Environment Forum, will have no responsibility for any errors in or omissions therefrom.

The production of this document was jointly funded by the Scottish Executive Health Department and the NHSScotland Property and Environment Forum.

NHSScotland, P&EEx, June 2001

Preface

SHTM 2010 gives guidance on the choice, specification, purchase, installation, validation, periodic testing, operation and maintenance of the following types of sterilizer in use in the National Health Service:

- a. clinical sterilizers:
 - (i) high-temperature steam sterilizers used for processing porous loads (including instruments and utensils wrapped in porous materials);
 - (ii) high-temperature steam sterilizers used for processing aqueous fluids in sealed containers;
 - (iii) high-temperature steam sterilizers used for processing unwrapped solid instruments and utensils;
 - (iv) dry-heat sterilizers (hot-air sterilizers);
 - (v) low-temperature steam (LTS) disinfectors and low-temperature steam and formaldehyde (LTSF) sterilizers;

NOTE: Despite their name LTSF sterilizers are disinfectors.

- (vi) ethylene oxide (EO) sterilizers;
- b. laboratory sterilizers:
 - (i) high-temperature steam sterilizers used with one or more specialised operating cycles;
 - (ii) culture media preparators.

No guidance is given on sterilization by irradiation, hydrogen peroxide, gas plasma or filtration. Users who wish to employ these processes bear the responsibility of ensuring that the validation procedures comply with the principles outlined in Part 3 of this SHTM, 'Validation and Verification', and that the intended operating procedures will ensure an efficacious process for the different types of load.

This SHTM is intended primarily as a guide for technical personnel, whether specialists in sterilizers and sterilization procedures or those responsible for maintenance and testing. It is also intended for those responsible for the day-to-day running of sterilizers, and will also be of interest to supplies officers, architects, estates managers and others in both the public and private sectors.

Detailed information on the planning and design of a sterile services department, including the level of provision of sterilizers, is given in Scottish Hospital Planning Note 13, *Sterile services department*. Guidance for



laboratory installations can be found in Scottish Hospital Planning Note 15, *Accommodation for pathology services*.

Although this edition of SHTM 2010 reflects established sterilizer technology, it is recognised that considerable scope exists for the utilisation of emerging technology in the management of sterilizers. This will be kept under review with the aim of introducing recommendations for such technology at the earliest opportunity so that the procedures essential for the efficient, safe and effective operation of sterilizers can be optimised.

The sterilizers described in this SHTM may not be suitable, without modification, for safely processing articles infected either with Hazard Group 4 pathogens or with agents, such as those associated with transmissible spongiform encephalopathies, which are unusually resistant to sterilization. Design considerations for sterilizers intended to process articles infected with such organisms are discussed in Chapter 14.

NOTE: Information about Hazard Groups may be found in the HSC document, *Categorisation of pathogens according to hazard and categories of containment* (4th edition 1995) compiled by the Advisory Committee on Dangerous Pathogens.



Contents

Preface	<i>page 2</i>
1. General	<i>page 9</i>
1.1 Introduction	
1.4 Legal frameworks for sterilization	
1.8 Medicinal products	
1.12 Medical devices	
1.18 Personnel	
1.36 Safety	
2. Procurement of a sterilizer - an overview	<i>page 14</i>
2.1 Introduction	
2.2 Purchasing a sterilizer	
2.3 What type of load needs to be processed?	
2.4 What type of sterilizer is required?	
2.5 What models are available?	
2.6 Where will the sterilizer be sited?	
2.7 What services are available?	
2.8 How big and how many?	
2.9 What other equipment will be needed?	
2.10 What specification?	
2.11 What sort of contract?	
2.12 Which manufacturer?	
2.13 What happens after delivery?	
3. Choice of sterilizer	<i>page 16</i>
3.1 Introduction	
3.2 Types of sterilizer	
3.4 Sterilants	
3.11 Choice of sterilizer	
3.16 Sterilization conditions	
3.25 Sizes and numbers	
3.27 Cycle time and performance class	
3.29 Chamber size	
3.32 Sizing calculation	
4. Specification and contract	<i>page 26</i>
4.1 Introduction	
4.2 Preparing a specification	
4.9 General design considerations	



4.14	Safety features	
4.20	Instrumentation	
4.28	Programmable electronic systems	
4.31	Overpressure protection	
4.33	Access to chamber drain	
4.34	Doors	
4.38	Materials of construction	
4.40	Fatigue life of pressure vessel	
4.43	Integral air compressors	
4.44	Integral steam generators	
4.45	Loading systems	
4.46	Invitation to tender	
4.51	Contract	
4.55	Delivery	
5.	Siting	<i>page 35</i>
5.1	Introduction	
5.5	Accommodation	
5.9	Plant room	
5.13	Loading area	
5.14	Free-standing sterilizers	
5.16	Transportable sterilizers	
5.21	Noise and vibration	
5.27	Lighting	
5.28	Electromagnetic compatibility	
6.	Engineering services	<i>page 40</i>
6.1	Introduction	
6.5	Electricity	
6.10	Water	
6.18	Compressed air	
6.20	Mains supply	
6.22	Local compressors	
6.25	Air quality	
6.26	Drainage	
6.29	Non-hazardous effluents	
6.34	Hazardous effluents	
6.39	Ventilation	
6.44	General room ventilation	
6.49	Room ventilation for LTSF and EO sterilizers	
6.54	Local exhaust ventilation	
6.62	Chamber exhaust ventilation	
6.68	Ethylene oxide gas	
6.69	Supply from cartridges	



6.70 Supply from cylinders

- 7. Steam supply** *page 54*
- 7.1 Introduction
- 7.6 Engineering considerations
 - 7.8 Capacity
 - 7.9 Pipework
 - 7.16 Materials
- 7.18 Dryness
 - 7.22 Excessive moisture
 - 7.24 Superheating
- 7.28 Non-condensable gases

- 8. Porous-load sterilizers** *page 63*
- 8.1 Introduction
- 8.5 Standard specifications
- 8.6 Additional specifications
 - 8.7 Air detector
 - 8.10 Port for air-flow metering device
 - 8.11 Absolute pressure indicator
 - 8.12 Bowie-Dick test cycle
 - 8.13 Extended drying

- 9. Fluid sterilizers** *page 65*
- 9.1 Introduction
- 9.5 Standard specifications
- 9.7 Additional specifications
 - 9.8 Cycle for plastic containers
 - 9.10 Heat exchanger
- 9.12 Monitoring and control by F_0

- 10. Sterilizers for unwrapped instruments and utensils** *page 69*
- 10.1 Introduction
 - 10.7 Transportable sterilizers
 - 10.10 Fixed sterilizers
- 10.11 Standard specifications
- 10.13 Additional specifications
 - 10.14 Operating cycle
 - 10.15 Temperature recorder



11.	Dry-heat sterilizers	<i>page 72</i>
11.1	Introduction	
11.6	Standard specifications	
11.7	Additional specifications	
12.	Low-temperature steam disinfectors and low-temperature steam and formaldehyde sterilizers	<i>page 74</i>
12.1	Introduction	
12.8	Standard specifications	
12.10	Additional specifications	
12.11	Room ventilation	
12.12	Local exhaust ventilation	
12.13	Formalin supply	
12.15	Degassing facilities	
12.16	Gas monitoring system	
13.	Ethylene oxide sterilizers	<i>page 77</i>
13.1	Introduction	
13.10	Types of sterilizer	
13.11	Low-pressure sterilizers	
13.13	High-pressure sterilizers	
13.16	Standard specifications	
13.18	Additional specifications	
13.19	Room ventilation	
13.20	Local exhaust ventilation	
13.21	Preconditioning facilities	
13.26	Preconditioning chamber	
13.30	Preconditioning room	
13.35	Degassing facilities	
13.39	Disposal of EO	
13.45	Gas monitoring system	
14.	Laboratory sterilizers	<i>page 83</i>
14.1	Introduction	
14.4	Provision of laboratory sterilizers	
14.13	Design considerations	
14.15	Air removal	
14.16	Cooling and drying	
14.17	Thermal door locks	
14.18	Standard specifications	
14.23	Additional specifications	
14.24	Instruments and controls	
14.26	Thermal door-lock override	



- 14.29 Load-temperature probe
- 14.30 Steam generators
- 14.33 Chamber drain
- 14.35 Top-loading sterilizers
- 14.36 Operating cycles
 - 14.38 Make-safe of small plastic discard
 - 14.42 Make-safe of contained fluid discard
 - 14.45 Sterilization of culture media
 - 14.49 Disinfection of fabrics
 - 14.53 Sterilization of glassware and equipment
 - 14.55 Free steaming
- 14.56 Culture media preparators
- 14.60 Discard boxes

Glossary *page 96*

Abbreviations *page 107*

References *page 109*

Appendix 1: Useful addresses *page 122*

Appendix 2: Information to be supplied by the manufacturer *page 123*

1. General

Introduction

- 1.1 This Part of SHTM 2010 covers the specification, purchase and installation of the various types of sterilizer used in hospitals, laboratories and other healthcare facilities.
- 1.2 Terminology used in sterilization has long been inconsistent and occasionally ambiguous. This SHTM introduces a set of terms consistent with European Standards (see paragraph 1.14) which, it is hoped, will in time be adopted by sterilization workers in the NHS. The Glossary contains definitions referred to in this Part.
- 1.3 The References contains full references for all the documents referred to in this Part and for selected documents of which the reader should be aware.

Legal frameworks for sterilization

- 1.4 There are now two legal frameworks applying to products from sterilizers. The long-standing legislation on medicinal products has now been joined by EU Directives on medical devices.
- 1.5 Purchasers must be clear as to whether the load items they intend to process in a sterilizer are classified as medicinal products or medical devices. While the practical requirements have much in common, their implementation is very different.
- 1.6 For the guidance given in this SHTM, the various types of sterilizer are presumed to be used primarily as follows:
 - a. for **medicinal products**: fluid sterilizers, dry-heat sterilizers;
 - b. for **medical devices**: porous load sterilizers, sterilizers for unwrapped instruments and utensils, dry-heat sterilizers, low-temperature steam (LTS) disinfectors, low-temperature steam and formaldehyde (LTSF) sterilizers, ethylene oxide (EO) sterilizers.
- 1.7 Where a sterilizer is purchased with the intention of processing both medicinal products and medical devices, purchasers should ensure that the requirements for both types of load are met.

Medicinal products

- 1.8 The manufacture and supply of medicinal products are controlled by a large body of legislation stemming from the EU Directives on medicinal products and enacted by the UK Medicines Acts and numerous Regulations. Further

details can be found in Part 1 of this SHTM, 'Overview and management responsibilities'.

- 1.9 The requirements for the manufacture of medicinal products are set out in the *Guide to good manufacturing practice for medicinal products* published in Volume IV of *The rules governing medicinal products in the European Community* (see References). This document is referred to as the 'GGMP' in this SHTM.
- 1.10 The GGMP contains an Annex on the *Manufacture of sterile medicinal products* which has considerable implications for the design of sterilizers and the premises in which they are used. Where purchasers are considering installing a sterilizer for the processing of medicinal products, the GGMP should be consulted at an early stage. Attention is drawn to these requirements in the relevant chapters of this SHTM.
- 1.11 Guidance on the application of medicines legislation to particular cases is beyond the scope of this SHTM and advice should be sought from the Medicines Control Agency (MCA).

Medical devices

- 1.12 Part 1 of this SHTM discusses the three EU Directives on the manufacture and supply of medical devices, active implantable medical devices and in-vitro diagnostic medical devices, which are being implemented by UK Regulations in stages from 1993 onwards. While the full implications of the legislation for the NHS are not yet clear, it is likely that all or most products for clinical use that are not classified as medicinal products will be classified as medical devices. Whether such medical devices will be subject to the Regulations is a complex issue turning on the relationship between the producer and the user of the devices and is beyond the scope of this SHTM.
- 1.13 One of the essential requirements of the directives is that "devices delivered in a sterile state must have been manufactured and sterilized by an appropriate, validated method". There is no equivalent of the GGMP for medical devices. Instead, the European Committee for Standardisation (Comité Européen de Normalisation, CEN) has prepared a number of draft European Standards on the manufacture of medical devices. These are known as "mandated" standards. Compliance with a mandated standard is considered to be a legal presumption of compliance with the essential requirements of the Directive it supports. Official notification of mandated European Standards supporting EU Directives is published in the Official Journal of the European Communities and in the London, Edinburgh and Belfast Gazettes.



- 1.14 Although compliance with a mandated standard is not the only way of complying with the directives, it is the simplest. Purchasers intending to process sterile medical devices in compliance with the directives should therefore ensure that their processes conform with one of the mandated standards. The following British Standards on the validation and control of sterilization processes have been mandated and are discussed in Part 3, 'Validation and verification', and Part 4, 'Operational management', of this SHTM:
- a. BS EN 556 covering the requirements for a device to be labelled "STERILE";
 - b. BS EN 554 covering sterilization by "moist heat" (that is, steam);
 - c. BS EN 550 covering sterilization by ethylene oxide.
- 1.15 These standards are themselves supported by the following standards for the specification of sterilizers which are discussed in this Part of this SHTM:
- a. BS EN 285 covering "large" porous load sterilizers;
 - b. BS EN 1422 covering EO sterilizers.
- 1.16 While the guidance given here is designed to be broadly consistent with the standards, SHTM 2010 should not be regarded as a substitute for the standards themselves when ascertaining compliance with EU Directives and the UK Regulations that implement them.
- 1.17 Guidance on the application of medical devices legislation to particular cases is beyond the scope of this SHTM and advice should be sought from the Medical Devices Agency (MDA).

Personnel

- 1.18 The following personnel are referred to in this Part of SHTM 2010. Further information, including qualifications and areas of responsibility, can be found in Part 1.
- 1.19 **Management** is defined as the owner, occupier, employer, general manager, chief executive or other person of similar authority who is ultimately accountable for the sole operation of the premises.
- 1.20 Depending on the nature of the organisation, this role may be filled by the general manager, chief executive, laboratory director or other person of similar authority. In small, autonomous installations the user may take on this function.
- 1.21 The **User** is defined as the person designated by management to be responsible for the management of the sterilizer.
- 1.22 In a hospital the user could be a sterile services department manager, laboratory manager or theatre manager; in primary care he or she could be

a general practitioner, dentist, or other health professional. Where a sterilizer is used to process medicinal products, the user is normally the production manager (see paragraph 1.30) in charge of the entire manufacturing process.

- 1.23 The **Competent Person (Pressure Vessels)** is defined as a person or organisation designated by management to exercise certain legal responsibilities with regard to the written scheme of examination of any pressure vessel associated with a sterilizer described in the Pressure Systems Safety Regulations 2000. The shorter term “competent person” is used in this SHTM.
- 1.24 The **Authorised Person (Sterilizers)** is defined as a person designated by management to provide independent auditing and advice on sterilizers and sterilization and to review and witness documentation on validation. The shorter term “authorised person” is used in this SHTM.
- 1.25 A list of suitably qualified authorised persons is maintained by the Institute of Healthcare Engineering and Estate Management (see Appendix 1).
- 1.26 The **Test Person (Sterilizers)** is defined as a person designated by management to carry out validation and periodic testing of sterilizers. The shorter term “test person” is used in this SHTM.
- 1.27 The **Maintenance Person (Sterilizers)** is defined as a person designated by management to carry out maintenance duties on sterilizers. The shorter term “maintenance person” is used in this SHTM.
- 1.28 The **Microbiologist (Sterilizers)** is defined as a person designated by management to be responsible for advising the user on microbiological aspects of the sterilization of non-medicinal products. The shorter term “microbiologist” is used in this SHTM.
- 1.29 The **Production Manager** is defined as a person designated by management to be responsible for the production of medicinal products.
- 1.30 The **Quality Controller** is defined as a person designated by management to be responsible for quality control of medicinal products with authority to establish, verify and implement all quality control and quality assurance procedures.
- 1.31 The **Laboratory Safety Officer** is defined as a person designated by management to be responsible for all aspects of laboratory safety including equipment, personnel and training relating to safety issues, and ensuring compliance with safety legislation and guidelines.
- 1.32 An **Operator** is defined as any person with the authority to operate a sterilizer, including the noting of sterilizer instrument readings and simple housekeeping duties.

- 1.33 The **Manufacturer** is defined as a person or organisation responsible for the manufacture of a sterilizer.
- 1.34 The **Contractor** is defined as a person or organisation designated by Management to be responsible for the supply and installation of the sterilizer, and for the conduct of the installation checks and tests. The contractor is commonly the manufacturer of the sterilizer.
- 1.35 The **Purchaser** is defined as the person or organisation who orders the sterilizer and is responsible for paying for it.

Safety

- 1.36 Extensive guidance on the safe operation of the various types of sterilizer is given in Part 4 of this SHTM. Guidance on safe practices in the testing of sterilizers is given in Part 3.
- 1.37 LTSF sterilizers and EO sterilizers both use toxic gases in the sterilization process. Occupational exposure to formaldehyde and EO is controlled by the Control of Substances Hazardous to Health Regulations 1999. Maximum exposure limits are set out in the annual Guidance Note EH40, *Occupational exposure limits*, published by the Health and Safety Executive. The limits shown in Table 1 (are as at 2001). These limits are statutory maxima but should not be regarded as representing a safe working exposure; employers have a legal obligation to ensure that the level of exposure is reduced so far as is reasonably practicable and in any case below the maximum exposure limit.
- 1.38 The COSHH Regulations 1999 also introduce new controls on biological agents which are of relevance to purchasers of laboratory sterilizers.

Table 1: Maximum exposure limits for atmospheric formaldehyde and ethylene oxide

Gas	Short-term maximum exposure limit		Long-term maximum exposure limit	
	[ppm]	[mg m ⁻³]	[ppm]	[mg m ⁻³]
Formaldehyde	2	2.5	2	2.5
Ethylene oxide	–	–	5	9.2

Note:

The short-term maximum exposure limit (STMEL) is the average exposure over any 15 min period.

The long-term maximum exposure limit (LTMEL) is the exposure over any 24 h period expressed as a single uniform exposure over an 8 h period.

COSHH does not specify a STMEL for EO. In the above table the STMEL is deemed to be three times the LTMEL in accordance with the recommendations of the Health and Safety Executive.

Source: COSHH Regulations 1999, HSE Guidance Note EH40 (2001).

2. Procurement of a sterilizer – an overview

Introduction

- 2.1 This chapter gives a short overview of the process of purchasing a sterilizer. It refers to more detailed information in subsequent chapters, including information specific to each type of sterilizer given in Chapters 8 to 14.

Purchasing a sterilizer

- 2.2 The purchase of a sterilizer can be broken down into the following sequence of steps.

What type of load needs to be processed?

- 2.3 Knowing the load is the first step in making the correct decision about which sterilizer to purchase. Different loads require different processes. Some loads are degraded by prolonged exposure to heat, others cannot withstand moisture or chemical sterilants, while others, owing to their materials or construction, cannot reliably be sterilized by conventional techniques.

What type of sterilizer is required?

- 2.4 In this SHTM sterilizers are classified as either clinical or laboratory sterilizers. Clinical sterilizers can use one of four different sterilizing agents (“sterilants”): high-temperature steam, hot air (dry heat), low-temperature steam and formaldehyde (LTSF) or ethylene oxide (EO). High-temperature steam sterilizers are specialised for processing porous loads, fluids or unwrapped instruments and utensils. They are also used in laboratory applications. Guidance on the selection of a sterilizer is given in Chapter 3.

What models are available?

- 2.5 Once the type of sterilizer has been settled, brochures and data sheets should be obtained from a number of manufacturers. The internal market in the European Union, supported by European Standards on sterilization, has considerably widened the choice open to purchasers. Guidance on what information to look for is given in Chapter 4.

Where will the sterilizer be sited?

- 2.6 Decide on the location of the sterilizer. Some sterilizers will require considerable building work. Guidance on siting is given in Chapter 5.

What services are available?

- 2.7 A sterilizer will require one or more of the following services: steam, electricity, water, compressed air, drainage, ventilation and sterilant gas supply. The manufacturers' data will show which services are required for each model. Determine which of these are available at the proposed site and the capacities of each service. It may be necessary to plan for a new service which would add greatly to the cost of the installation. Further information about services may be found in Chapter 6. Steam supply is crucial and is discussed in detail in Chapter 7.

How big and how many?

- 2.8 Establish the likely weekly workload that the sterilizer will have to process. Calculate the size and number of sterilizers required to process the workload. A judgement has to be made on the trade-off between size and number. Guidance on how to do this is given in Chapter 3.

What other equipment will be needed?

- 2.9 A sterilizer installation may require auxiliary equipment such as steam generators, air compressors, preconditioning facilities, degassing facilities and gas disposal plants. If required, these are discussed in Chapters 8 to 14.

What specification?

- 2.10 Most sterilizers will be constructed to either a European Standard or a British Standard. In some cases additional specifications will be required and these are detailed in Chapters 8 to 14. Advice on preparing a detailed specification for the sterilizer is given in Chapter 4.

What sort of contract?

- 2.11 Once the specification has been completed, a contract should be drawn up for the supply and installation of the sterilizer. Guidance on suitable forms of contract is given in Chapter 4.

Which manufacturer?

- 3.12 Invite a number of manufacturers to tender for the supply of the sterilizer. Guidance on tendering is given in Chapter 4.

What happens after delivery?

- 2.13 Chapter 4 contains advice on the documentation that the manufacturer should include with the sterilizer. After delivery the sterilizer is subject to a programme of validation. This is discussed in detail in Part 3 of this SHTM.

3. Choice of sterilizer

Introduction

- 3.1 This chapter contains information relevant to the choice of a new sterilizer. It discusses the types of sterilizer and the loads for which they are suitable, and gives guidance on selecting the size and number of sterilizers required for a given application.

Types of sterilizer

- 3.2 This SHTM groups sterilizers into two broad categories according to the use to which they are put:
- a. **clinical sterilizers** are designed to process medical devices or medicinal products;
 - b. **laboratory sterilizers** are designed to process laboratory goods and materials that are neither medical devices nor medicinal products and are not intended for use in the clinical care of patients.
- 3.3 The operation of sterilizers in the two categories should be kept strictly separate. Loads intended for processing in a clinical sterilizer should not be put into a laboratory sterilizer and vice versa.

Sterilants

- 3.4 Sterilizers can also be classified according to the agent (the sterilant) used to effect sterilization. The following sterilants are in common use in the NHS:
- a. high-temperature steam;
 - b. dry heat (hot air);
 - c. low-temperature steam and formaldehyde (LTSF);
 - d. ethylene oxide (EO).
- 3.5 Because of its superior sterilizing qualities, high-temperature steam is the sterilant of choice. Machines using other sterilants should be reserved either for loads which would be damaged by exposure to high-temperature steam (such as certain surgical devices) or for loads that would not be sterilized by exposure to high-temperature steam (such as non-aqueous fluids).
- 3.6 Low-temperature steam used without formaldehyde is not considered to be a sterilant but is commonly used for disinfection.



- 3.7 Clinical sterilizers may employ any one of the four sterilants. The laboratory sterilizers described in this SHTM use only high-temperature steam.
- 3.8 High-temperature steam sterilizers are by far the most common sterilizers used in the NHS, and are manufactured in three basic types according to the nature of load they are designed to process: porous loads, fluids, or unwrapped instruments and utensils. The operating cycles are designed to cope with the differing properties of the various types of load, and it is essential that a sterilizer is used only for the type of load for which it is designed.
- 3.9 High-temperature steam inactivates pathogens by a combination of moisture and heat; water molecules combine with proteins and genetic material, which are then susceptible to thermal disruption. The process is well understood and the attainment of sterilization conditions can normally be confirmed by simple physical measurements. (This is not so for sterilizers using gaseous sterilants, where microbiological test procedures are necessary.)
- 3.10 Many high-temperature steam sterilizers are large machines requiring permanently installed engineering services (including good-quality steam) and purpose-built accommodation. Smaller models are transportable and generate steam from an internal water reservoir.

Choice of sterilizer

- 3.11 The choice of sterilizer will be governed by the nature of the loads required to be sterilized. Table 2 summarizes the type of load that can and cannot be processed in each type of machine. More detailed guidance on appropriate processes for different load items can be found in *Sterilization, disinfection and cleaning of medical equipment: Part 1: Principles*, published by the Medical Devices Agency, *Sterilization and disinfection of heat-labile equipment* published by the Central Sterilising Club, and in Part 4 of this SHTM.

**Table 2: Suitable and unsuitable loads for different types of sterilizer**

Type of sterilizer	Suitable loads	Unsuitable loads
Porous load (high-temperature steam)	Porous items; items with narrow lumens that may trap air and inhibit the penetration of steam. <i>Examples:</i> any item with porous wrapping, dressings, clothing, towels	Items which would be damaged by exposure to steam at 121 - 137°C
Fluid (high-temperature steam)	Aqueous fluids in sealed glass or plastic containers. <i>Examples:</i> intravenous fluids	Non-aqueous fluids
Unwrapped instruments and utensils (high-temperature steam)	Solid metal items. <i>Examples:</i> surgical or dental instruments, bowls	Items with narrow lumens that may trap air and inhibit the penetration of steam. <i>Examples:</i> ENT suction tubes, laparoscopic instruments, orthopaedic reamers
Dry heat	Items which would not be sterilized by high-temperature steam, or would be damaged by doing so. <i>Examples:</i> solids, powders, non-aqueous fluids, ointments, ophthalmic instruments, items in closed containers	Aqueous fluids and items which would be damaged by prolonged exposure to dry heat at 160-200°C. <i>Examples:</i> fibre optics, rubber, plastics
Low-temperature steam and formaldehyde (LTSF)	Wrapped or unwrapped items which would be damaged or not sterilized by high-temperature steam or dry heat. <i>Examples:</i> certain items containing plastic components, electromedical equipment	Items which would be damaged by exposure to steam or formaldehyde gas at 71-80°C; sealed, oily or greasy items; items contaminated with body fluids
Ethylene oxide (EO)	Wrapped or unwrapped items which would not be sterilized by steam or dry heat or would be damaged by doing so. <i>Examples:</i> heat-labile plastic items, heart valves, electromedical equipment	Items which can be sterilized by other means; soiled items; items previously sterilized by irradiation. <i>Examples:</i> ventilatory and respiratory equipment
Laboratory (high-temperature steam)	Laboratory materials and equipment. <i>Examples:</i> infected materials to be made safe, culture media, glassware and other equipment	Medical devices, medicinal products and other items to be used in the clinical care of patients



- 3.12 Purchasers should be aware that items suitable for a particular type of sterilizer may still require different operating cycles, which need to be specified before purchase. For example, a porous-load sterilizer is required for wrapped instruments and microbiological filters. However, a cycle suitable for instruments may be harmful to the filters unless the rate of change of pressure is reduced to prevent rupture of the membrane. Similarly, a container with a small orifice will also require a porous-load sterilizer but the duration of each air removal pulse will need to be extended to allow for pressure equilibration; otherwise the air will remain in the container and sterilization will not be achieved. Guidance on the modification of operating cycles to suit particular loads (process development) is given in Part 4 of this SHTM.
- 3.13 More information about the different types of sterilizer is given in Chapters 8 to 14.

Table 3: Suggested information to be obtained from manufacturers before inviting tenders

Information required	Objective
The standards (BS or EN) to which the sterilizer is designed and constructed and a statement of compliance	To confirm that the sterilizer meets recognised specifications for design, construction, performance and safety
Installation data , including the overall dimensions and mass of the sterilizer; the number of supports and the maximum floor loading at each support; the clearance required for access and the masses of the principal heavy components	To enable the user to establish whether the proposed location is suitable for the sterilizer and the extent of any building work required (see Chapter 5)
The volume of the usable chamber space expressed both in litres and an integral number of sterilization modules, and its principal dimensions in metres	To enable the user to determine the capacity of the sterilizer and hence the number of sterilizers required to process the workload
Specifications for each of the engineering services required by the sterilizer	To enable the user to establish that the demands of the sterilizer are within the capacity of the services in the proposed location (see Chapters 6 and 7)
A description of the operating cycles offered with the sterilizer, including numerical and graphical representations of typical values of cycle variables throughout each cycle and the extent to which pre-set variables may be adjusted	To enable the user to confirm that the cycles are appropriate for the anticipated loads
For each operating cycle and sterilization temperature the cycle time and corresponding performance class for the relevant full load tests specified in Part 3 of this SHTM	To enable the user to determine the capacity of the sterilizer and hence the number of sterilizers required to process the workload
The mean and peak sound power levels generated by the sterilizer, expressed as an A-weighted sound power level measured as described in Appendix D of BS 3970: Part 1 or in Part 5 of this SHTM, 'Good practice guide'	To enable the contractor to confirm that the sound pressure level after installation, as measured by the method given in Part 3 of this SHTM, will not exceed that specified for the location (see Chapter 5)
The fatigue life of the pressure vessel	To enable the user to estimate the working life of the sterilizer (see Chapter 4)
The type of doors and information on the necessary space required for the movement of the doors (see Chapter 4)	To enable the user to make the necessary provisions in the design of the loading area (see Chapter 5)

3.14 Advice on individual cases should be sought from the authorised person before any decision is made. Where an LTSF or EO sterilizer is being considered the microbiologist should also be consulted.

3.15 Once the type of sterilizer has been decided, preliminary enquires should be made with a number of manufacturers to obtain specifications and price lists. Table 3 indicates some of the information that will be useful for planning purposes and which should be obtained at this stage.



Sterilization conditions

- 3.16 For the purposes of this SHTM the following definitions have been adopted.
- 3.17 The **cycle variables** are the physical properties, such as time, temperature, pressure, humidity and sterilant gas concentration, that influence the efficacy of the sterilization process.
- 3.18 Most operating cycles have a stage in which the load is exposed to the sterilization (or disinfection) conditions for a specified length of time. This period is known as the **holding time**.
- 3.19 The **sterilization conditions** are the ranges of the cycle variables which may prevail throughout the chamber and load during the holding time.
- 3.20 The holding time is preceded by a period in which the sterilization conditions are present in the chamber but not yet present throughout the load. This is known as the **equilibration time**.
- 3.21 Together, the equilibration time and the holding time constitute the **plateau period**. While the plateau period can always be determined from the recorded chamber temperature, the equilibration and holding times cannot be distinguished unless the temperature in the part of the load that is slowest to reach the sterilization temperature is also being recorded or measured.
- 3.22 Certain LTSF sterilizers may achieve sterilization by exposing the load to a series of pulses of formaldehyde rather than a single holding time.
- 3.23 For EO sterilizers the plateau period is equivalent to the **gas exposure time**. The holding time cannot be determined by thermometry and is therefore of no practical interest.
- 3.24 For steam and dry heat sterilizers, the sterilization conditions are specified by a **sterilization temperature band**, defined by a minimum acceptable temperature, known as the **sterilization temperature**, and a maximum allowable temperature. The higher the sterilization temperature, the shorter the holding time and the more rapidly the cycle is completed. A sterilization temperature band can also be quoted for LTSF and EO sterilizers, but since these processes depend primarily upon chemical action such a band is not a complete specification of the sterilization conditions. Bands for the different types of sterilizer are listed in Table 4.

Table 4: Sterilization temperature bands

	High-temperature steam				Dry heat			LTS	LTSF	EO
Sterilization temperature (°C) ^a	115	121	126	134	160	170	180	71 ^b	71	30-56
Maximum allowable temperature (°C)	118	124	129	137 ^c	170	180	190	80	80	^d
Minimum holding time (min)	30	15	10	3	120	60	30	10	180 ^e	^f

Note:

- a. The temperature setting on the automatic controller will not generally be the sterilization temperature, but a higher temperature within the sterilization temperature band.
- b. Disinfection temperature.
- c. British Standards permit 138°C.
- d. For EO, the maximum allowable temperature will normally be 4°C above the sterilization temperature.
- e. For LTSF, the sterilization conditions may specify either a continuous holding time or the number of pulses for formaldehyde required to achieve sterilization.
- f. For EO, the “gas exposure time” is determined for each sterilizer by microbiological methods during commissioning but is typically 2-7 hours depending upon sterilization temperature and gas concentration.

Sizes and numbers

3.25 It is difficult to give precise information on the sizes and number of sterilizers required for particular installations since in practice there are significant variations in patterns of use. The following guidance is applicable to all types of sterilizer. More detailed advice and examples of how to calculate sizes and numbers of sterilizers in a Sterile Services Department (SSD) is given in Scottish Hospital Planning Note 13 for porous loads, and in Supplement 1 to Scottish Hospital Planning Note 13 for EO sterilizers.

3.26 The number of sterilizers required will depend on two critical properties of the machine: the cycle time (denoted by a performance class) and the chamber size (denoted by the volume of the usable chamber space).

Cycle time and performance class

3.27 The time required to complete an operating cycle depends both on the design of the sterilizer (especially the methods used to remove air from the chamber and to heat and cool the load) and on the type and size of load to be processed. An operating cycle is assigned a performance class which is related to the time required to process a standard full load, as specified in the tests described in Part 3 of this SHTM. A Class 1 cycle will be complete in less than 10 min, while a Class 20 cycle will take over 13 hr. The relation between cycle time and performance class is given in Table 5. If the cycle time is to be extended to dry difficult loads, this should be allowed for when calculating the number of sterilizers required.

Table 5: Performance classes for sterilizers

Class	Full load cycle time [mins]	Class	Full load cycle time [mins]	Class	Full load cycle time [mins]	Class	Full load cycle time [mins]
1	0 – 10	6	61 – 90	11	241 – 300	16	541 – 600
2	11 – 15	7	91 – 120	12	301 – 360	17	601 – 660
3	16 – 30	8	121 – 150	13	361 – 420	18	661 – 720
4	31 – 45	9	151 – 180	14	421 – 480	19	721 – 780
5	46 – 60	10	181 – 240	15	481 – 540	20	over 780

3.28 Loading conditions that present a greater challenge to the cycle than the full loads specified in Part 3 of this SHTM will require further investigation and performance qualification to establish a cycle time. The authorised person will advise on this.

Chamber size

3.29 The size of a sterilizer is denoted by the volume of the usable chamber space, commonly expressed in litres. The usable chamber space is the space inside the chamber which is not restricted by chamber furniture and which is available to accept the load. It should be distinguished from the total chamber volume, which is equal to the volume of water required to fill the chamber and is therefore larger than the usable chamber space.

3.30 With the gradual introduction of European Standards on sterilization, the size of larger sterilizers will be denoted by an integer number of sterilization “modules” which can be accommodated within the usable chamber space. One module is a rectangular box measuring 300 x 300 x 600 mm, of volume 54 litres. In the European Standards a “large” sterilizer can accommodate one or more modules; a “small” sterilizer has a capacity of less than one module. Table 6 lists the recommended sizes for different types of sterilizer.

Table 6: Recommended sizes for different types of sterilizer

Type	Usable chamber space [modules] ^a						
	<1	1	2	4	6	9	12
Porous load	-	-	X ^b	-	X	X	X
Fluid	-	-	X	X	X	X	X
Unwrapped instrument	X	X ^b	X ^b	-	-	-	-
LTSF	-	-	-	-	X	X	-
Dry heat	-	-	-	X	-	-	-
EO	-	X	X	-	-	-	-
Laboratory	X	-	-	-	X	X	-

- a. A module is a rectangular box measuring 300 x 300 x 600 mm, of volume 54 litres (see paragraph 3.30).
- b. May be used in a surgical facility where supply from an SSD is impracticable or not cost effective.

3.31 In the case of sterilizers for unwrapped instruments and utensils and laboratory sterilizers, small transportable units of capacity less than one module are available and may be the most economical solution where workloads are light.

Sizing calculation

3.32 Once the cycle time is known, the size and number of sterilizers to be purchased can be calculated. Size and number are complementary: in principle, the same workload can be processed by a single large sterilizer or a number of smaller sterilizers.

3.33 The first step in making this decision is to establish the workload which the sterilizer is intended to process, expressed in modules per week. (For some types of sterilizer it may be more appropriate to express the workload in other units; for example trays or discard boxes per week.) This is not simply the bulk volume of goods to be processed, but the volume they will occupy inside the sterilizer allowing for spacing within the chamber. Spacing is particularly important for sterilizers using mixtures of steam and air and for dry-heat sterilizers. An item which cannot be fitted into a single module should be allowed two or more modules as appropriate.

- 3.34 Once the workload is established, the capacity for a sterilizer of given size can be calculated from

$$\text{capacity} = 60 \frac{V f_v \times T f_T}{t_c} \text{ modules/week}$$

where

V = the volume of the usable chamber space (modules);

f_v = the loading factor, the average fraction of the usable chamber space occupied by a load (typically 0.5 for an SSD);

T = the “open hours”, the number of hours each week for which the sterilizer unit will be operational;

f_T = the utilisation factor, the fraction of the open hours for which the sterilizer is available to process loads. This should allow for loading and unloading, periodic testing and maintenance, and warm-up cycles. It should be chosen so that a sterilizer may be withdrawn from service for planned maintenance and periodic testing without jeopardising production. For an SSD the utilisation factor is typically 0.55;

t_c = the cycle time for the selected operating cycle (minutes).

- 3.35 The minimum number of sterilizers required to process the workload can then be calculated from

$$\text{Number of sterilizers required} \times \frac{\text{workload}}{\text{capacity}}$$

- 3.36 Purchasers should make the above calculation for a number of different sizes of sterilizer to establish the combinations of size and number that will satisfy the workload requirement.

- 3.37 In practice, the number of sterilizers of the same type in a single installation will be usually at least two and rarely more than four.

- 3.38 Where more than one sterilizer of the same type is installed, they should be of the same size and from the same manufacturer. This will allow common loading systems to be used.

- 3.39 If further sterilizers are likely to be purchased in the future, then consideration should be given to the extra space required both in the plantroom and in the loading area.

- 3.40 Special considerations for laboratory sterilizers are discussed in Chapter 14.

4. Specification and contract

Introduction

- 4.1 This chapter discusses general specifications for sterilizers and the steps to be taken in inviting tenders and issuing a contract. The validation procedure, which begins on installation of the sterilizer, is discussed in detail in Part 3 of this SHTM.

Preparing a specification

- 4.2 Purchasers are strongly recommended to seek assistance from the authorised person when preparing a specification for a sterilizer.
- 4.3 To keep abreast of changing requirements, purchasers should ensure that they consult the latest editions of any standards and other specification documents, including any amendments issued after publication. The authorised person will advise on this.
- 4.4 Most sterilizers are constructed either to a European Standard (EN) or a British Standard (BS). A summary of the current relevant standards is given in Table 7. As many British Standards will be replaced by European Standards in due course, purchasers should specify a European Standard where one exists. The relevant standards are discussed in the 'Standard specifications' section of each chapter.

Table 7: British and European Standards on sterilizers

Topic	British Standard
Clinical sterilizers	
Porous load	BS 3970: Parts 1 & 3, BS EN 285
Fluid	BS 3970: Parts 1 & 2
Unwrapped instruments	BS 3970: Parts 1 & 4
Dry heat	-
LTS	BS 3970: Parts 1 & 5
LTSF	BS 3970: Parts 1, 5 & 6
EO	BS EN 1422
Laboratory sterilizers	BS 2646 Parts 1-5
Electrical safety	BS EN 61010: Part 1
Steam	BS EN 61010: Part 2-041
Dry heat	BS EN 61010: Part 2-043
LTSF and EO	BS EN 61010: Part 2-042

Full references for these standards are given in the Reference section

- 4.5 In some cases the standard specifications may not be adequate for sterilizers to be used in the public service. In these cases, additional specifications are listed below for general design considerations (see paragraphs 4.9 onwards) and, if appropriate, in an 'Additional specifications' section of each chapter.
- 4.6 Purchasers are strongly advised to use the NHS Model Engineering Specification C14, *Sterilizers* and the *C14 User Guide*, both published by NHS Estates, when ordering sterilizers. C14 is an exhaustive, detailed statement of specifications, conforming both with current standards and with the recommendations of this SHTM. There should be no need for any further documentation, alterations or additions to be included in the tender documents.
- 4.7 Details of the proposed location for the sterilizer should be stated clearly in the specification.
- 4.8 Except when the manufacturer is responsible for the installation of the machine, the type and standard of packing for delivery of the sterilizer should be specified. Where site conditions are likely to be poor and damage could occur, a substantial dustproof transit case may be necessary.

General design considerations

- 4.9 The following design considerations are applicable to all or most types of sterilizer, but are not necessarily required by the current standards. Where applicable they should be included in the specification for any sterilizer to be operated in the NHS.
- 4.10 All sterilizers and associated equipment are classed as “work equipment” and should comply with the Provision and Use of Work Equipment Regulations 1998 (PUWER 98), (see Part 1 of this SHTM). Purchasers are reminded that under the Regulations it is the responsibility of the employer, not the manufacturer, to provide a sterilizer that is “suitable for the purpose for which it is used or provided”.
- 4.11 All sterilizers made or sold in the UK from 1 January 1996 should conform to the emission and immunity requirements of the Electromagnetic Compatibility Regulations 1992. This may be achieved by compliance with BS EN 50081 (emission) and BS EN 50082 (immunity). The manufacturer should be informed of any local sources of electromagnetic disturbance which may affect the operation of the sterilizer (see Chapter 5).
- 4.12 For maintenance purposes, side, back and top panels for free-standing sterilizers should be easily removable and replaceable.
- 4.13 Special foundations are not normally required. The weight of the sterilizer, which can be as much as 2.5 tonnes when fully loaded, should be borne by at least four pads, each measuring at least 150 x 150 mm. Floor mountings should be designed to minimise vibration.

Safety features

- 4.14 Safety features should be designed in accordance with the British Standard code of practice for safety of machinery, PD 5304: 2000, and the British Standard for the safety of electrical equipment, BS EN 61010.
- 4.15 The design of the control system should ensure that the door cannot be opened except by a key code or tool until the cycle is either complete or returned to a safe condition and a fault is indicated.
- 4.16 The sterilizer should conform to the requirements listed under *Safeguards and Interlocking* in HSE Guidance Note PM73, *Safety at autoclaves*.
- 4.17 The manufacturer should provide a list of all safety devices together with their settings and methods of adjustment.
- 4.18 All safety devices should be designed to fail in a manner which does not cause a safety hazard to personnel.
- 4.19 A safety hazard should not be caused by an error in the control or indication system.



Instrumentation

- 4.20 Whilst it is preferable that the recording system is wholly independent of control and indication, a system which combines both control and instrumentation may be used, providing that any fault which could cause a failure to attain specified parameters within all parts of the load is either indicated or recorded. If this requirement cannot be met, an independent recording system should be provided. (See also paragraph 4.30.)
- 4.21 Where an instrument has a facility for adjusting one or more preset variables (such as a thermostat) the adjustment should be by means of a key, code or tool not available to the operator.
- 4.22 Where more than one instrument is fitted in the same area, every effort should be made to obtain a uniform appearance. As an alternative to discrete instruments, any or all of the required displays may be provided by a single display unit.
- 4.23 Where a fault is indicated in the form of an error message shown on a visual display unit, it should be clearly distinguishable from normal messages, for example, by use of a different colour or larger size of text. The indication should remain displayed until acknowledged by the operator.
- 4.24 The sterilizer contractor should be required to carry out adjustments to the instruments on site so that the accuracies specified at the sterilization temperature can be met with the plant running and under the conditions normally prevailing on site.
- 4.25 An indicator should show which stage of the operating cycle is in progress and indicate "cycle complete" at the end of the cycle.
- 4.26 A five-digit counter should be provided to indicate the cumulative total of cycles started. The counter should be tamper-evident or sealed.
- 4.27 Provision should be made for the attachment of the test instruments required for the tests specified in Part 3 of this SHTM.
- a. For temperature testing, a connection should be provided to permit the entry of sensors into the chamber, as described in BS EN 285. A suitable gland for attachment to the connection is illustrated in Part 3 of this SHTM.
 - b. For pressure or humidity testing, test tees and valve cocks with sealing plugs should be fitted to permit connection of test instruments for the verification and calibration of all pressure and humidity instruments permanently fitted to the sterilizer. The connection should be as described in BS EN 285.

Programmable electronic systems

- 4.28 Modern sterilizers frequently use programmable electronic systems (PES) for control and data recording. Where such systems are used, they should be designed in accordance with the principles set out in the two parts of the HSE document, *Programmable electronic systems in safety related applications*.
- 4.29 Where a PES is used for control or monitoring of the process, the values of cycle variables critical to process performance and determined during validation should be documented in the validation report regardless of whether or not they are held in the PES memory. The version number of the software should be available for display when required.
- 4.30 Combined control and instrumentation systems that are wholly operated by means of PESs should incorporate at least two timing systems, independent of each other, such that the timer used to control the holding time is verified by the other timer.

Overpressure protection

- 4.31 Overpressure safety valves should be fitted to protect components that may be damaged by inadvertent high pressures. These include the chamber, jacket, pressurised door-sealing system, heat exchanger system and ballast air system. The discharge from safety valves should be terminated in a safe position (see paragraph 7.15).
- 4.32 The steam pipework should include a pressure-reducing system with a separator on the high-pressure side. The system should be fitted with a strainer and trap to prevent condensate accumulating in the system.

Access to chamber drain

- 4.33 For steam sterilizers, the chamber drain should be positioned so that any debris caught on the strainer can be seen and removed by the operator without the need to dismantle any part of the sterilizer.

Doors

- 4.34 A single door is preferred. Sterilizers with a door at each end (“double-ended” sterilizers) create problems of maintenance and ventilation and should only be considered where alternatives have been discounted.
- 4.35 Power-operated doors are desirable on sterilizers of 300-litre capacity and over. The following designs are available:
- sliding doors (vertical or horizontal);
 - side-hinged doors;
 - bell-shaped sterilizer, where the chamber is raised vertically from a fixed bedplate.

- 4.36 The choice of design for any particular installation will depend on the workload, space restrictions, price and ease of maintenance. With side-hinged doors there is a risk of the operator touching the hot inside face as the door is opened. If hinged doors are required, the specification should state whether they are to be hinged on the left-hand or right-hand side of the opening. Bell-shaped sterilizers require special guards to ensure the safety of the operator when the chamber is being lowered.
- 4.37 It should be possible to clean the contact surfaces of the door seal without removing parts of the sterilizer.

Materials of construction

- 4.38 Table 8 summarises the materials to be used for clinical sterilizers and for laboratory sterilizers.

Table 8: Recommended materials of construction

	Clinical sterilizers	Laboratory sterilizers
Pressure vessel and steam generator	Group A	Group A, B or C
Pipework for circulating media coming into contact with load	Group E	Group G
Pipework for circulating media not coming into contact with load	Group J or K	Group H, J or K

Groups are defined in Annex 1 of BS EN 285.

- 4.39 The fatigue life of sterilizer vessels (see paragraph 4.40) constructed from dissimilar materials welded together can be considerably reduced by unpredictable high stresses caused by differential expansion and weld inconsistencies. For this reason the use of carbon-steel jackets or stiffeners should be avoided on stainless-steel chamber shells.

Fatigue life of pressure vessel

- 4.40 The fatigue life of a sterilizer vessel will depend on the level of alternating stresses caused by the following:
 - a. changes of pressure within the chamber;
 - b. differential temperature changes within the chamber and jacket (if fitted);
 - c. differential expansion;
 - d. stresses “locked” within the pressure-retaining parts of the vessel.
- 4.41 Vessels should be designed to withstand $25,000/t_C$ operating cycles, where t_C is the minimum cycle time (in hours) corresponding to the performance class quoted by the manufacturer.
- 4.42 The manufacturer should determine the fatigue life by the method given in Part 5 of this SHTM (reprinted from BS 3970: Part 1).

Integral air compressors

- 4.43 European and British Standards permit the use of built-in air compressors for sterilizers but do not give specifications, current experience indicates, however, that certain small compressors of the type fitted to domestic refrigerators are not suitable for use in sterilizers. Unless they are meticulously maintained, a small air leak can cause them to run continuously, causing rapid carbonisation of the oil and consequent failure of the sterilizer pneumatic system.

Integral steam generators

- 4.44 Where an integral steam generator is fitted to the sterilizer, it should be equipped with blow-down facilities to enable sludge to be expelled from the boiler.

Loading systems

- 4.45 Sterilizer loading systems should be designed with regard to the Manual Handling Operations Regulations 1992 and the Lifting Operation and Lifting Equipment Regulations 1998 (LOLER).

Invitation to tender

- 4.46 Once detailed specifications have been drawn up, manufacturers should be invited to tender for the supply and, if required, the installation of the sterilizer.
- 4.47 When inviting tenders, purchasers should follow the principles described in Scottish Capital Investment Manual and PROCODE.
- 4.48 The purchaser should specify that the sterilizer manufacturer operates a quality system in accordance with the principles described in BS 5750 and the EN 9000 series. If the manufacturer has both designed and manufactured the sterilizer, the quality system should conform with EN 9001. If the sterilizer has been manufactured to a design supplied by a third party, the manufacturer's quality system should conform to EN 9002. In either case the manufacturer should ensure that each supplier of accessories, fittings and other materials also operates an appropriate quality system.



- 4.49 Prospective contractors should be given the following information:
- a. that each sterilizer will be subject to a validation process as described in Part 3 of this SHTM;
 - b. unless otherwise specified, that the installation checks and tests specified in the validation process must be satisfactorily completed before the sterilizer can be accepted;
 - c. whether the installation checks and tests are to be witnessed by the purchaser's representative (normally the test person);
 - d. the date by which all services will be available;
 - e. the date by which the validation process is expected to be completed.
- 4.50 In assessing tenders, purchasers should not automatically opt for the lowest quoted price. An unusually low tender should not be chosen without further investigation into the financial circumstances of the prospective contractor.

Contract

- 4.51 For procurement of sterilizers Conditions of Contract as advised by PROCODE may be used. Modifications to suit local purchasing policy may be required.
- 4.52 Consideration may also be given to the use of alternative forms of contract, for example MF/1 (available from the Institution of Electrical Engineers, the Institution of Mechanical Engineers or the Association of Consulting Engineers) or the Joint Contracts Tribunal (JCT) suite of documents (available from RIBA Publications). Addresses are given in Appendix 1.
- 4.53 Purchasers using other forms of contract are strongly advised to seek legal advice, from the Central Legal Office (CLO) especially where a contract proposed by the prospective contractor is being considered.
- 4.54 Other contracts, notably for the authorised person, the test person, the maintenance person, the competent person and the microbiologist, may need to be considered at this time (see Part 1 of this SHTM). In awarding these contracts, purchasers should ensure that there is no conflict of interest that would compromise the validation process set out in Part 3 of this SHTM.



Delivery

- 4.55 On or before delivery of the sterilizer, the manufacturer should provide the purchaser with the information specified in Appendix 2.
- 4.56 Sterilizers for a particular scheme should not be ordered and stored on site for long periods prior to installation and validation. Disregard of this recommendation could result in the installation of a technically obsolescent sterilizer. Where a long delay is unavoidable, conditions for storage should be agreed with the manufacturer.

5. Siting

Introduction

- 5.1 This chapter sets out some of the considerations to be taken into account when siting a sterilizer. A thorough discussion of the planning requirements for a sterile services department (SSD) is given in HBN 13. Additional guidance on the siting of ethylene oxide (EO) sterilizers may be found in Chapter 13 and in Scottish Hospital Planning Note 13, Supplement 1; *Ethylene oxide sterilization section*. Guidance on the siting of laboratory sterilizers is given in Chapter 14 and in BS 2646: Part 2. Guidance on accommodation for ethylene oxide gas cylinders, manifolds and canisters is given in Part 5 of this SHTM.
- 5.2 The room in which a sterilizer is installed should meet the requirements of the Workplace (Health, Safety and Welfare) Regulations 1992, which have far-reaching implications for the design of sterilizer accommodation.
- 5.3 Fire safety precautions should comply with the NHS in Scotland Firecode series published by the NHS in Scotland Property and Environment Forum Executive.
- 5.4 Where possible, sterilizers should be transported as a whole and not partially stripped.

Accommodation

- 5.5 Except where sterilizers are free-standing (paragraph 5.14) or transportable (paragraph 5.17), a sterilizer installation will normally be separated into two areas: a plantroom containing the sterilizer itself, services and ancillary equipment; and an adjacent loading area from which the sterilizer is loaded and unloaded. The areas are divided by a partition wall into which the front panel and door of the sterilizer are set.
- 5.6 The wall aperture should meet the tolerances quoted in BS EN 285. The contractor should be required to provide the trim to the wall or provide the panelling. Fascia panels should be adequately supported and insulated to minimise vibration and heat transmission from the plantroom to the loading area. Foamed plastic materials which are either combustible or subject to degradation at the operating temperatures should not be used, nor should asbestos products. Suitable specifications for such insulation may be found in NHS Model Engineering Specifications C02, *Thermal insulation*.



- 5.7 Maintenance staff should be able to enter the plantroom without passing through the loading area. Direct access between the plantroom and loading area should be provided for use during testing. Operators will normally require access to the loading area only.
- 5.8 If a sterilizer with a door at each end is installed (a “double-ended” sterilizer), arrangements for maintenance should be from the “dirty” end. Except where the product would be jeopardised or a microbiological hazard created, maintenance access from the “clean” end should also be provided.

Plantroom

- 5.9 Wherever practicable the sterilizer should be located on the ground floor and the plantroom should have an outside wall. This arrangement will facilitate easy access for engineering staff and for plant replacement. It will also simplify safety requirements for ventilation and drainage, particularly for low-temperature steam and formaldehyde (LTSF), EO and laboratory sterilizers.
- 5.10 The plantroom floor should be non-slip and waterproofed to avoid damage to rooms and equipment which may be below the sterilizers. To facilitate cleaning, the floor should fall naturally to a drain.
- 5.11 Adequate clearance around the machines is essential for access and maintenance. The minimum clearance should be 1.0 m around all parts to which access for routine maintenance is necessary. The minimum ceiling height is 2.7 m above floor level. Spacing should be such that it is possible to replace any sterilizer without disturbing others in the same installation. Particular care should be taken to ensure that sufficient clearance is allowed for large items, such as vacuum pumps, to be withdrawn from the sterilizer frames.
- 5.12 Extra space should be allowed for installation and maintenance of free-standing equipment such as steam generators, air compressors and water conservation systems. Possible future expansion should be considered. For EO sterilizers, a separate but adjacent manifold room will be required for gas cylinders (see paragraph 6.74).

Loading area

- 5.13 Where carriage or trolley loading is used, the minimum clearance for access to the sterilizer should be 3.0 m or twice the length of the carriage loading system, whichever is the greater. Careful attention should be paid to height adjustment, so that all sterilizers in a group can be served wherever possible by a common loading system.

Free-standing sterilizers

- 5.14 Certain permanently installed sterilizers, such as smaller laboratory machines, may be “free standing”, that is, installed in a room with no separation into plantroom and loading area. Such installations may present problems of safety and access, and are not recommended where a more

conventional arrangement is possible. Where a free standing installation is unavoidable, the authorised person should be consulted at an early stage to ensure that adequate safety precautions are taken.

- 5.15 A free-standing sterilizer may not meet the environmental quality control standards required for the manufacture of medicinal products or medical devices (see Chapter 1). Advice may be obtained from the authorised person.

Transportable sterilizers

- 5.16 Benches on which transportable sterilizers are placed should comply with HTM 67, *Laboratory fitting-out system*.
- 5.17 The sterilizer should be placed within 2 m of a switched 13 A socket outlet. Extension flexes should not be used.
- 5.18 The pressure relief valve should be able to discharge freely and safely. Equipment which could be damaged by steam or moisture should not be placed near the sterilizer.
- 5.19 It has been known for the door of a transportable sterilizer to be blown off with considerable force; the sterilizer should therefore be sited so that a safety hazard is not created in the event of an accident. Sterilizers in dental practices should preferably be sited in a different room to that used for operating. If this is impossible, the sterilizer door should face in such a direction that there is no hazard to patients or staff.
- 5.20 Users should be aware of the heat and water vapour that may be emitted in normal operation by even a small sterilizer and make appropriate provision for ventilation (see Chapter 6). The authorised person will advise on suitable arrangements.

Noise and vibration

- 5.21 Sound pressure levels sensed in a room are a function of the sound power generated by the sterilizer and the acoustic design of the room in which the sterilizer is installed.
- 5.22 European and British Standards do not specify permitted sound power levels. The sterilizer manufacturer should state at the time of tendering the A-weighted sound power level determined in accordance with the method detailed in Part 5 of this SHTM. Purchasers should be aware that the uncertainty inherent in this method can amount to a standard deviation of 5 dB for sources containing discrete tones and 4 dB for wide-band noise sources. These uncertainties should be taken into account in the acoustic design of the room in which the sterilizer is installed. The design should ensure that sound pressure levels stated in the sound pressure test described in Part 3 are not exceeded.



- 5.23 The sound pressure levels specified in Part 3 are for an area or space where the sterilizer is operating under normal working conditions. The levels include noise from all sources including the sterilizer.
- 5.24 The room in which the sterilizer is to be installed should be located and designed so that the noise transmitted from the room does not increase the sound pressure levels in adjacent rooms in excess of the levels specified in SHTM 2045; *Acoustics*. Account should be taken of all transmission paths, including open windows and building structures. A fascia panel should not be used to separate a noise-sensitive area from the operating parts of the sterilizer without additional insulation (this may double as thermal insulation – see paragraph 5.6).
- 5.25 If the sterilizer is in or adjacent to a main building or a noise-sensitive area, open louvres in internal doors and partitions should be avoided; doors should be solid, self-closing and a good fit in their frames, preferably with compressed rubber seals. If this affects natural ventilation, mechanical ventilation may be required (see Chapter 6). The need for such a solution can usually be avoided in the planning stage.
- 5.26 Vibration transmitted to the building structure is generally produced by pumps, motors and on/off valves connected to the services. If vibration is likely to be a problem the following measures are recommended:
- transmission of vibration through service connections can be avoided by the use of flexible connections;
 - pumps and motors associated with sterilizers should be resiliently mounted, whether or not they are integral with the sterilizer;
 - the forcing frequency of the vibration generator should be taken into account when designing vibration isolators.

Lighting

- 5.27 Fluorescent lighting should be used. The stroboscopic effect of the lighting should be minimised in the plantroom by the use of two tube fittings suitably adapted for this purpose or by the use of two phases for the lighting circuits. The fittings should be sited longitudinally between the sterilizers. Further guidance on lighting may be found in *Lighting guide: hospitals and health care premises*, published by the Chartered Institution of Building Services Engineers (CIBSE).



Electromagnetic compatibility

- 5.28 Although a new sterilizer will be designed to comply with the Electromagnetic Compatibility Regulations 1992, purchasers should establish whether existing equipment on the premises is likely to give rise to electromagnetic disturbance at the intended location of the sterilizer. If so, the sterilizer manufacturer should be informed at an early stage. Further guidance may be found in SHTM 2014; *Abatement of electrical interference*.

6. Engineering services

Introduction

- 6.1 A sterilizer installation will require one or more external services including steam, electricity, water, compressed air, drainage, ventilation and ethylene oxide gas. The manufacturer should make clear at an early stage which services will be needed and the detailed requirements for each, as outlined in Table 9. Steam supply is the most critical of the services and is considered in detail in Chapter 7.
- 6.2 If the services are to be installed by a contractor other than the contractor installing the sterilizer, care must be taken to ensure that the size and location of terminations are agreed before the contracts are placed.
- 6.3 All services should be terminated within the plantroom by appropriate valves and isolators within 2.0 m of the sterilizer.
- 6.4 Care should be taken to ensure that pipework and cables used to connect the sterilizer to the service terminations are of adequate size to meet the demands of the sterilizer. Inadequate services may cause malfunctioning. Pipework and cables should be installed close to a wall and not over the top of a sterilizer.

Electricity

- 6.5 The electrical power requirements will depend on a number of factors, such as the type of sterilizer and the method used to generate steam. (Local or integral electrical steam generators will result in a high electrical load.) Some sterilizers will require a three-phase supply. The manufacturer should provide details of the type of supply (AC or DC), number of phases, frequency, and voltages with tolerances and loading.
- 6.6 Each sterilizer should be connected via an isolator. The type of isolator will depend on the nature of the supply:
- isolators for transportable sterilizers with a maximum current demand of 13 A may be of the simple plug and socket-outlet type, with the plug correctly fused and the socket outlet switched;
 - where a three-phase-and-neutral supply is necessary, or where a maximum single-phase current demand is more than 13 A, the sterilizer should be wired directly to the isolator. The switch should isolate all poles simultaneously and each pole should be fused separately. The cable from isolator to sterilizer should be fixed and protected from the effects of heat, water and steam.

Table 9: Information on services to be obtained from the sterilizer manufacturer

Steam	<ul style="list-style-type: none"> a. the maximum flow and usage rate; b. the acceptable range of steam supply pressures; c. where steam is generated within the sterilizer, the maximum hardness value, the range of pH and the conductivity of the boiler feed water.
Electricity	<ul style="list-style-type: none"> a. type of supply, e.g. AC or DC; b. number of phases (normally one or three) and whether neutral is required for a 3-phase supply; c. supply voltage and frequency including acceptable minimum and maximum values; d. maximum continuous power in kW or kVA.
Water	<ul style="list-style-type: none"> a. the minimum and maximum supply pressure; b. the flow at minimum pressure; c. the volume used per cycle; d. the maximum temperature of the water; e. the maximum permissible chlorine and chloride content.
Compressed air	<ul style="list-style-type: none"> a. the minimum and maximum supply pressure; b. the flow at minimum pressure; c. the volume of air used for each cycle.
Sterilant gas	For EO sterilizers, details of the type of sterilant supply required and the quantity required for a single cycle.
Drainage	<ul style="list-style-type: none"> a. the maximum flow of effluent (water and condensed steam) to the hospital drain; b. the maximum temperature of the effluent on leaving the sterilizer; c. the sources of effluent contributing to the total outflow.
Ventilation	<p>The following quantities should be given as peak values during the cycle and as average values over a complete cycle:</p> <ul style="list-style-type: none"> a. the heat (in watts) transmitted to the environment when the sterilizer is operated in a nominal ambient temperature of $23 \pm 2^{\circ}\text{C}$ in still air with the doors closed; b. for a recessed sterilizer, the heat (in watts) transmitted to the loading area when the sterilizer is operated in a nominal ambient temperature of $23 \pm 2^{\circ}\text{C}$ in still air with the doors closed.

6.7 Within the loading area an additional switch should be provided so that the operator can electrically isolate the sterilizer or group of sterilizers in the event of an emergency. The switch should be placed between the normal operating position and the exit door.

- 6.8 Sterilizers used to process heat-sensitive loads should be connected to the essential supplies circuit, if available, to avoid heat damage in the event of a power failure. Guidance on the supply of electricity in the event of a failure of the normal supply is given in SHTM 2011; *Emergency Electrical Services*.
- 6.9 All electrical installations should conform to the IEE Regulations contained in BS 7671. Further guidance is given in SHTM 2007; *Electrical services: supply and distribution* and SHTM 2020; *Electrical safety code for low voltage systems* (Escode - LV).

Water

- 6.10 A water supply of potable quality may be needed for equipment such as condensers, heat exchangers and water-sealed vacuum pumps (feed-water for steam generation is discussed in Chapter 7). Details of the water-quality requirements, the maximum pressure, minimum pressure and maximum flow rate should be obtained from the sterilizer manufacturer.
- 6.11 To prevent possible contamination of the water main, the supply should be connected to the sterilizer via a backflow protection device, such as a break tank.
- 6.12 The temperature of water used for sterilizers with vacuum systems should not normally exceed 15°C. Higher water temperatures will reduce the efficiency of vacuum pumps and compromise the specified vacuum levels.
- 6.13 Performance will also deteriorate if the water is very hard or contains large quantities of solids in suspension. The hardness of the water should be in the range 0.7-2.0 mmol litre⁻¹. Hardness values outside these limits may cause scaling and corrosion problems. This can be overcome by the installation of simple water-treatment plant at the sterilizer site.
- 6.14 Water economy devices, which sense the temperature of cooling water and adjust the flow rate accordingly, should be fitted to reduce water consumption.
- 6.15 Chlorine and chlorides may cause corrosion of stainless steel in the presence of heat. Advice on maximum permissible levels should be obtained from the sterilizer manufacturer.
- 6.16 A copious supply of piped water is required for emergency use in any area where a spillage of liquid EO may occur. The supply should be capable of delivering at least 18 litre min⁻¹ at a minimum pressure of 1.5 bar.
- 6.17 Further guidance on water supply is given in SHTM 2027; *Hot and cold water supply, storage and mains services*.

Compressed air

- 6.18 A compressed-air supply may be required for the operation of controls and also for pressure ballasting in certain fluid and laboratory sterilizers. Where the sterilizer does not contain an integral air compressor (see paragraph 4.43), the air may be supplied from a mains supply or from a local compressor.
- 6.19 If pressure ballasting is required, additional reservoir capacity or compressors will be needed. The system should be capable of delivering at least $12 \text{ m}^3\text{h}^{-1}$ at 8 bar.

Mains supply

- 6.20 If air is supplied by pipeline from a central air-compressor system, a pressure gauge, of the Bourdon type complying with BS EN 837, should be fitted inside the plantroom and terminated with an isolation valve.
- 6.21 A reducing valve or other automatic device should be fitted to reduce the pressure of the air delivered to the sterilizer to not more than the maximum working pressure of the sterilizer. A pressure relief valve will normally be required.

Local compressors

- 6.22 Where it is not practicable to obtain compressed air from a mains supply, a dedicated compressed-air facility should be installed to supply the sterilizers and other equipment. At least two compressors should be provided, with autochange between the two. The system should be sized to meet all the compressed air requirements of the unit and give priority to the sterilizers.
- 6.23 The compressors are likely to be too noisy to be installed in the sterilizer plantroom, and it is better to place them in a dedicated location away from any noise-sensitive areas.
- 6.24 Components which require servicing or maintenance, such as dryers and filters, should be installed in locations where they can be readily serviced or exchanged.

Air quality

- 6.25 Quality of air is critical and certain types of sterilizer will incorporate the appropriate filters. If the purchaser is to be responsible for supplying filtered air, note the following points:
- air for controls should be free of liquid water, filtered to $25 \mu\text{m}$ ($5 \mu\text{m}$ for precision controls) and lubricated with micro-fog oil particles of $2 \mu\text{m}$ or less;
 - air that could come into direct contact with the load, such as air for pressure ballasting or door seals, should be filtered to remove contaminating oil-mist and micro-organisms. It should have not more



than 0.5 mg of oil per cubic metre of free air (measured at 1013 mbar and 20°C; see ISO 554), be filtered to an efficiency of at least 95% when tested in accordance with BS 3928 and be free of bacteria.

Drainage

- 6.26 Condensate from the jacket, heat exchangers and steam traps is suitable for recovery and should be returned to the steam generating plant where there are means for recovery.
- 6.27 All other effluent from a sterilizer is potentially contaminated and should be disposed of to the main drain. Effluent may originate from one or more of the following sources:
- air, condensate and steam from the chamber drain, which may contain chemicals and micro-organisms, especially those from a make-safe process;
 - discharge from a water-sealed vacuum pump, ejector or chamber vent, which may also contain micro-organisms;
 - water from a chamber cooling system;
 - water introduced to cool and dilute the discharge from the chamber.
- 6.28 Drainage requirements for different types of sterilizer are summarised in Table 10 and discussed below.

Non-hazardous effluents

- 6.29 Effluent from steam-only sterilizers should pass via an air break into a tun-dish or tank before being discharged to the drain. The air break should be preserved at all times so that the sterilizer and its associated piping cannot be contaminated by reverse flow from the drainage system. This can be achieved by ensuring that under all working conditions the discharge rate from the tun-dish is such that the maximum flow rate of effluent from the sterilizer will not cause the water level in the tun-dish to rise to the level of the outlet from the sterilizer. For clinical sterilizers the above equipment is normally provided by the manufacturer and contained within the sterilizer itself, but for certain laboratory sterilizers it is the responsibility of the purchaser to install it in the plantroom.
- 6.30 The drain system from the plantroom should be trapped and designed to pass the flow rate of water, air and condensed steam specified by the manufacturer, with account taken of peak demands during the operating cycle.

Table 10: Discharge and ventilation requirements for different types of sterilizer

Type of sterilizer	Effluent discharge	Ventilation
LTSF sterilizers	Trapped and vented, sealed to main drain. No open gulleys	General room ventilation ten changes/hour, non-recirculating. Discharge to stack LEV on sterilizer door, Discharge to stack
EO sterilizers	Small - no drainage required Large - Trapped and vented, sealed to main drain. No open gulleys Very large sterilizers may require fan-assisted venting of drain	General room ventilation ten changes/hour, non-recirculating. Discharge to stack Small - chamber exhaust to stack LEV on sterilizer door, aeration facility door and manifold room. Discharge to stack
Laboratory sterilizers	Trapped and vented, sealed to main drain. No open gulleys	General room ventilation, non-recirculating. Filtered discharge for Category 3 and 4 laboratories
Other sterilizers	Direct to main drain	General room ventilation. No special requirements

- 6.31 Means should be provided to prevent, as far as possible, flash steam being liberated into the atmosphere or causing condensation on electrical equipment.
- 6.32 The discharge temperature from a steam sterilizer is unlikely to exceed 80°C, but in the event of failure of the diluting and cooling system it might reach 100°C. The materials used for the construction of the drainage system should be chosen to withstand this temperature. Attention is drawn to the legal requirement (Public Health (Scotland) Act 1897 as amended) that the maximum temperature of any liquid to be emptied into the public sewer or communicating drain is 43°C. This may be interpreted as relating to the main building connection to the sewer and not to the internal building drain.
- 6.33 Where a tank supplies water to a water-sealed vacuum pump or a water pump used for an ejector vacuum system, the overflow discharge from the tank should also include an air break.

Hazardous effluents

- 6.34 A sealed and vented drain is required for LTSF sterilizers, large EO sterilizers (supplied from cylinders), EO gas disposal units and laboratory sterilizers used to make-safe discard material. Small EO sterilizers (supplied from cartridges) discharge gas only (see paragraph 6.62).
- 6.35 Chamber drains and vents should have a sealed independent discharge which should be vented and trapped before it is connected to the drainage system. Open tun-dishes should not be used. The vent should be not less than 30 mm in diameter and terminated above roof level, clear of ventilation

air inlets or windows. Steam should not issue from the vent. A “Hazardous Discharge” warning notice should be fitted next to it. A similar arrangement should be provided for any safety valves.

- 6.36 EO is considerably denser than air. For sterilizers with chamber volumes greater than 300 litres there is a risk that the amount of gas discharged into the drainage system could result in pockets of explosive mixtures of EO and air accumulating at the bottom of the vent stack. Although there is no known case of such an explosion in the UK, consideration should be given to installing a fan-driven gas-capture system to draw gas from above the liquid effluent before the liquid is discharged to the main drain. The gas should either be disposed of chemically (see Chapter 13) or discharged at a high level. The vent should meet the requirements of the local exhaust ventilation system (see paragraph 6.61).
- 6.37 In certain circumstances, such as special research activities involving high concentrations or volumes of pathogens in Hazard Group 3, additional safeguards may be required for laboratory sterilizers. The advice of HSE should be sought in such cases.
- 6.38 Where a laboratory sterilizer is to be used to make-safe material contaminated with Hazard Group 4 pathogens, further containment, filtration or heat treatment will be necessary. Again, advice should be sought from HSE.

Ventilation

- 6.39 Ventilation of the area near the sterilizers is needed to remove both excessive heat and odours, and also sterilant gases such as formaldehyde and EO.
- 6.40 General room ventilation will be sufficient for most sterilizers, but chamber exhaust ventilation will be required for certain small EO sterilizers and local exhaust ventilation will be required to remove local concentrations of EO or formaldehyde. The requirements are summarized in Table 10 and discussed below.
- 6.41 Electrical systems used in ventilation systems should take account of the explosion risk associated with ethylene oxide and comply with the requirements of BS EN 61010: Part 2-042.
- 6.42 All ventilation systems should meet the ventilation requirements of the Workplace (Health, Safety and Welfare) Regulations 1992.
- 6.43 Further guidance on ventilation systems may be found in SHTM 2025; *Ventilation in healthcare premises*.

General room ventilation

- 6.44 The air change rate should be related to the heat and vapour emission from the sterilizer and associated equipment and pipework so that working conditions remain acceptable and control equipment is not adversely affected. The ambient temperature in the plantroom with all plant running normally should not be allowed to exceed 35°C at any time.
- 6.45 Current experience indicates that a 400-litre high-temperature steam sterilizer with door closed will release by radiation and convection approximately 1.0 kW into the loading area and 4.0 kW into the plantroom. Sliding-door machines installed behind a fascia panel with a separate door will release almost all the heat into the plantroom. With the door open, additional heat into the loading area might typically be 3.5 kW for a side-hinged door and 3.0 kW for a sliding door. More specific figures should be obtained from the manufacturer of the sterilizer (see Table 9).
- 6.46 In designing a ventilation system, account should also be taken of the heat emitted from the sterilized load after it has been removed from the chamber.
- 6.47 Ventilation air to the plantroom may be taken in either at low level from the loading area or from an independent source and should be discharged to the outside.
- 6.48 Where the plantroom does not have an outside wall, heat emissions will need to be absorbed by a recirculating cooling unit with remote fan-cooled condensers. The rating of the units should have sufficient reserve capacity to reduce the temperature to 30°C in order to provide a safe and acceptable working environment for staff during maintenance of the plant. Additional plant space is required for the installation of the cooling units.

Room ventilation for LTSF and EO sterilizers

- 6.49 For LTSF, EO and laboratory sterilizers, the loading area should be maintained at a lower pressure than the main corridor and at a higher pressure than the plantroom. The discharge to the outside should not be sited where the extracted air will be drawn into the building via windows or ventilation inlets.
- 6.50 Areas containing LTSF or EO sterilizers and aerators should have a dedicated, non-recirculating room-ventilation system which ensures that air movement is from the operator towards the sterilizer both during normal operation and also when local exhaust ventilation (see paragraph 6.54) is operative. During normal operation, exposure to formaldehyde and EO should not be allowed to exceed the exposure limits given in Table 1.
- 6.51 Room ventilation for LTSF and EO sterilizers should be designed to permit the extraction of the maximum possible leakage of gas within a reasonable time. This requires at least ten air changes an hour. For example, Figure 1 shows the relationship between the volume of a room and the number of air



changes required to reduce the concentration of EO to 5 ppm when a standard 134 g cartridge is discharged into the room.

- 6.52 Sensing devices and interfaces should be provided to ensure that if the room ventilation fails to maintain a rate of flow sufficient to ensure ten air changes an hour:
- a. a visual and audible alarm is given;
 - b. where the operating cycle has progressed beyond the point where sterilant has been admitted into the chamber, it is not possible to open the door at the end of the cycle until the room ventilation is restored to normal operation;
 - c. it is not possible to start a new cycle until the room ventilation is restored to normal operation.

Requirement 6.52(b) may be waived if the load can be transferred from the sterilizer to an aeration facility without gas escaping into the atmosphere. This would normally require a local exhaust ventilation system with a common extractor hood covering both the door of the sterilizer and the door of the aeration facility. If such a system is installed, it should be validated to demonstrate that the specified rates of flow (see paragraph 6.54) can be achieved when the room ventilation is not operating.

Figure 1: Air changes required to reduce the concentration of ethylene oxide to 50 ppm and 5 ppm following the sudden release of 134g of the gas into the workroom

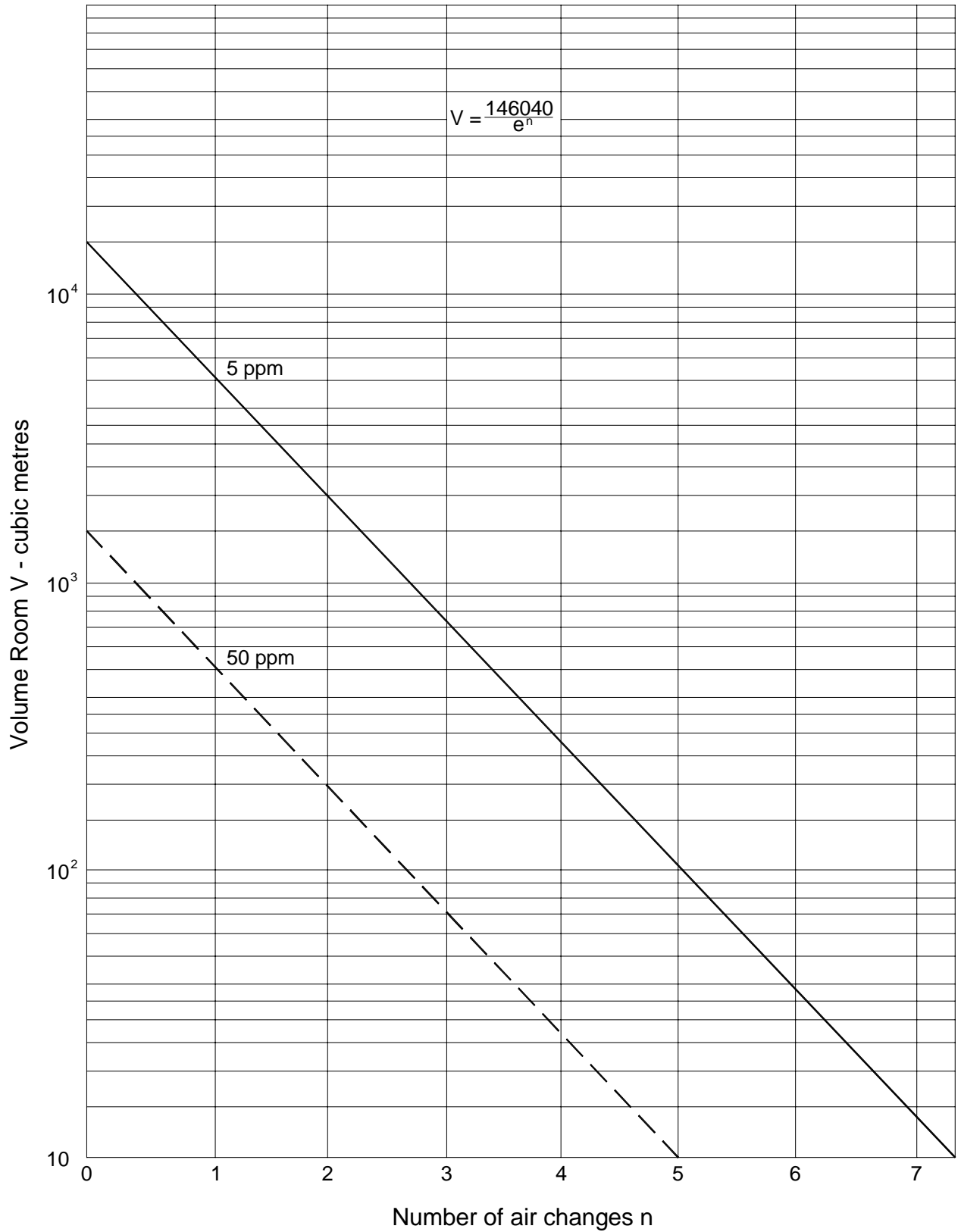

Local exhaust ventilation

- 6.54 In addition to the room ventilation, LTSF sterilizers, EO sterilizers and EO aerating equipment should be fitted with an independent local exhaust ventilation (LEV) system having a minimum flow of $0.3 \text{ m}^3 \text{ s}^{-1}$ at each extractor hood. The system should have hoods near any place where formaldehyde or EO could be released into the atmosphere; for example, around the doors of sterilizers and aeration cabinets and in the manifold room where cylinders are connected to the EO supply manifold (see paragraph 6.74).
- 6.55 When activated, the LEV should operate for a preset period of up to 30 min.
- 6.56 Sensing devices and interfaces should be provided to ensure that the LEV is activated on the following occasions:
- when the door is ready to be released at the end of an operating cycle;
 - when sterilant cylinders are being changed;
 - on a pressurization failure of inflatable or pressure-activated door seals;
 - whenever the atmospheric concentration of sterilant gas exceeds a preset safe level not greater than the short-term maximum exposure limit given in Table 1.
- 6.57 Controls should be provided both within and outside the loading area to activate the LEV manually.
- 6.58 Sensing devices and interfaces should be provided to ensure that if the LEV, when activated, fails to attain or maintain a flow of at least $0.3 \text{ m}^3 \text{ s}^{-1}$:
- an audible and visual alarm is given;
 - it is not possible to open the door at the end of the cycle until the LEV is restored to normal operation;
 - it is not possible to start a new cycle until the LEV is restored to normal operation.
- 6.59 Make-up air provision, preferably by indirect means, will be required.
- 6.60 Ducts designed to carry formaldehyde or EO gas should be maintained under negative pressure, for example by locating the extractor fan at the discharge end.
- 6.61 The discharge should be above roof level and away from windows, doors and air intakes. This may be the same vent used to discharge gas from the chamber. A "Hazardous Discharge" notice should be fitted next to the outlet. For EO sterilizers supplied from cylinders, the discharge stack should be fitted with a flame arrestor.

Chamber exhaust ventilation

- 6.62 Small EO sterilizers (supplied from cartridges) and EO aerators will require a chamber exhaust ventilation (CEV) independent of the room and LEV systems.
- 6.63 The CEV for a sterilizer should extract gas from the sterilizer chamber during the gas removal stage and throughout any aeration stage.
- 6.64 The CEV for an aerator should operate whenever an aeration cycle is in operation. If an aeration room is used, the temperature and ventilation should be controlled within adjustable ranges from ambient temperature to 55°C and nominally zero to ten air changes an hour.
- 6.65 Interfaces should be provided so that in the event of a failure of the CEV:
- an audible and visual alarm is given;
 - where the operating cycle has progressed beyond the point where EO has been admitted to the chamber, it is not possible to open the door at the end of the cycle until the CEV is restored to normal operation;
 - it is not possible to start a new cycle until the CEV is restored to normal operation.
- 6.66 The discharge should be above roof level and away from windows, doors, and air intakes. This may be the same vent used for the LEV. A “Hazardous Discharge” notice should be fitted next to the outlet.
- 6.67 The CEV alarm circuit should be independent of the mains electricity supply. It is recommended that the CEV system itself be connected to the essential supplies circuit in the event of a mains power failure.

Ethylene oxide gas

- 6.68 Ethylene oxide gas may be supplied either from disposable cartridges (pure EO) or from cylinders (pure EO or EO mixed with diluent gases). Both the containers and the delivery system are subject to the Pressure Systems Safety Regulations 2000.

Supply from cartridges

- 6.69 The number of cartridges kept within the plantroom should be limited to those actually in use and those required for immediate stand-by. Cartridges should be stored as described in Part 5 of this SHTM. Cartridges for immediate use may be held in the loading area.

Supply from cylinders

- 6.70 All pipework intended to carry EO should be in stainless steel. Flexible hoses should be of stainless steel, preferably lined with PTFE or nitrile rubber.
- 6.71 Cylinders should be stored as described in Part 5 of this SHTM.
- 6.72 Where EO is stored at a temperature below its normal boiling point (10.7°C) it is essential to exclude air by pressurising the cylinder with nitrogen or other diluent gas. Even when nominally empty of liquid EO, cylinders should be maintained at a minimum pressure of 2 bar. Nitrogen used for pressurising will stay in the gaseous state and will not mix with the liquid EO.
- 6.73 Fittings to the cylinder, such as valves and pressure gauges, should be protected against mechanical damage. Cylinders should be secured to prevent them falling over or colliding during storage and transport.
- 6.74 Cylinders should be connected to the sterilizer supply line in a dedicated manifold room separate from the plantroom. The room should not have direct access from the loading area. The manifold room should meet the requirements of SHTM 2022. Local exhaust ventilation should be installed as described in paragraph 6.54.
- 6.75 A duty and a reserve cylinder should each be connected to a common gas manifold via a manual stop valve, at least one automatic stop valve, and a vent with a stop valve (for use during cylinder change and inert gas purging). These are in addition to the valve on the cylinder itself. The system should be designed and constructed to allow only one cylinder at a time to supply gas to the sterilizer. An indicator should show which cylinder is being used.
- 6.76 Each cylinder should be located on weighing scales with sufficient tare capacity for the largest cylinder expected to be used. The scales should be accurate enough to determine the mass of gas admitted to an accuracy of $\pm 1\%$ of the mass of gas required to fill the empty chamber to the preset operating pressure. Recording scales are preferable, since the data obtained may be used in the routine monitoring of the operating cycle.
- 6.77 An automatic change-over facility is recommended so that the reserve cylinder can be brought on-line without interruption of the supply. An electrical signal from the weighing scales may be used to determine when the duty cylinder is nearly empty and to initiate the change-over automatically.
- 6.78 The temperature of the cylinders should not be allowed to exceed the maximum stated by the supplier, and in any case not more than 45°C. The temperature of the manifold and supply line should be kept above 11°C to prevent EO condensing inside the pipework.



- 6.79 The number of cylinders kept within the manifold room should be limited to those actually in use and those required for immediate stand-by.
- 6.80 Cylinders of an inert gas such as nitrogen should be available for purging the pipework before maintenance and testing.

7. Steam supply

Introduction

- 7.1 A continuous supply of saturated steam is required for steam sterilization, low-temperature steam and formaldehyde (LTSF) sterilization and for humidification in certain ethylene oxide (EO) sterilizers and EO preconditioning units.
- 7.2 The critical variables are the dryness of the steam (expressed as a dryness value) and the level of non-condensable gases (expressed as a fraction by volume). Before a newly installed or replaced sterilizer is handed over to the user, the steam supply should be examined and tested by the methods described in Part 3 of this SHTM to ensure that it is satisfactory.
- 7.3 Users should note that where the steam is supplied from the mains, quality can vary greatly during the course of a working day. In many hospitals, steam demand is greatest early in the morning when sterile service departments (SSDs), kitchens and laundries may start work at the same time. Care should be taken to sample the steam at times throughout a typical working day to gauge the likely range of steam quality.
- 7.4 Where a sterilizer is to be used in the aseptic production of medicinal products, the steam should also be free of pyrogens. Details on the supply of apyrogenic steam can be found in SHTM 2031; *Clean steam for sterilization*.
- 7.5 BS EN 554 and BS EN 285 provide guidance on the chemical quality of steam and quality of environment in contact with a medical device. Further guidance on steam quality can be found in SHTM 2031; *Clean steam for Sterilization*.

Engineering considerations

- 7.6 Except where the steam is generated within the chamber (such as in transportable sterilizers), steam is generally obtained from the hospital mains and the delivery of high-quality steam depends on careful engineering.
- 7.7 Occasionally, suitable steam may be available from the high-pressure hot-water systems used in some hospitals. Steam from this source is not recommended for porous-load sterilizers since the steam is generally too wet for reliable sterilization, even with a recommended minimum return temperature of 150°C.

Capacity

- 7.8 The steam service should be designed to meet the maximum steam demand of the sterilizer for short periods, while keeping the fall in pressure before the final pressure-reducing system to not more than 10%. Experience shows that a single porous-load sterilizer of up to 600 litres requires a boiler of at least 50 kW and storage to meet a peak demand of 125 kW for 15 min. The effect on the steam supply of the demands of other sterilizers and equipment should be carefully considered.

Pipework

- 7.9 Except for vertical rises between floors, steam pipework should be designed so that any condensate flows by gravity in the same direction as the steam. This general principle applies equally to steam mains, branch connections and pipework on the sterilizer itself. Air vents and steam traps should be fitted at each vertical rise. Care should be taken to trap, drain and return any condensate which may be collected in pockets in the pipework. Dead-legs should be avoided.
- 7.10 The accumulation of condensate in the periods when the sterilizer is not in operation should be avoided, particularly in any part of the pipework and fittings between the take-off from the manifold and the sterilizer chamber. This can be achieved by the correct declination of each portion of pipework and by adequate trapping throughout the steam distribution system.
- 7.11 Figure 2 shows a suggested layout for the steam service in the plantroom. The supply main should terminate in an adequately vented and trapped manifold, not less than 150 mm nominal bore, running the entire length of the room (this provides for future expansion). A vent, with a cooling pot, should be installed on the manifold upstream of the supply pipes to individual sterilizers. A pressure gauge should be fitted to the manifold.
- 7.12 Where the supply pressure at the inlet to the sterilizer would exceed the maximum value specified by the manufacturer, a pressure-reducing system and separator should be fitted to the supply pipe at least 3 m from the sterilizer. Heat loss from the section between the pressure-reducing system and the sterilizer will help prevent superheating (paragraph 7.24).
- 7.13 If the sterilizer manufacturer has not already fitted them, an appropriate and correctly installed separator and steam trap should be fitted upstream of the sterilizer reducing valve.
- 7.14 Three suitable test connections should be provided on the supply pipe to each sterilizer to permit the attachment of a needle valve, a pitot tube and a temperature sensor as shown in Figure 2. (Details of the use of these items can be found in Part 3 of this SHTM.)



- 7.15 Careful attention should be paid to the location of all pressure relief valves to ensure that the sterilizer is properly protected. Relief valves and their discharge pipes should be large enough to prevent the pressure in the supply pipe rising to more than 10% above the design pressure for the sterilizer. The discharge pipe should terminate outside the building in a safe, visible position not affected by frost. Any rising discharge pipe should be fitted with a drain at the lowest point to prevent the accumulation of condensate. A tell-tale pipe of narrow bore should be connected to the drain point and terminate inside the plantroom.

Materials

- 7.16 Steel and copper piping have traditionally been used for steam supply, but these materials will not be acceptable if compliance with the EU Directives on medical devices is required. Suggested minimum standards for steam purity are given in BS EN 285 (analytical methods for testing for these impurities, including tests for pyrogens, is included in SHTM 2031), but these are unlikely to be achieved with plant currently installed in the UK. Moreover, steam of such purity would be severely corrosive to the steel and copper piping in the majority of sterilizers in use in the NHS.

Figure 2: Layout of steam service in the plantroom

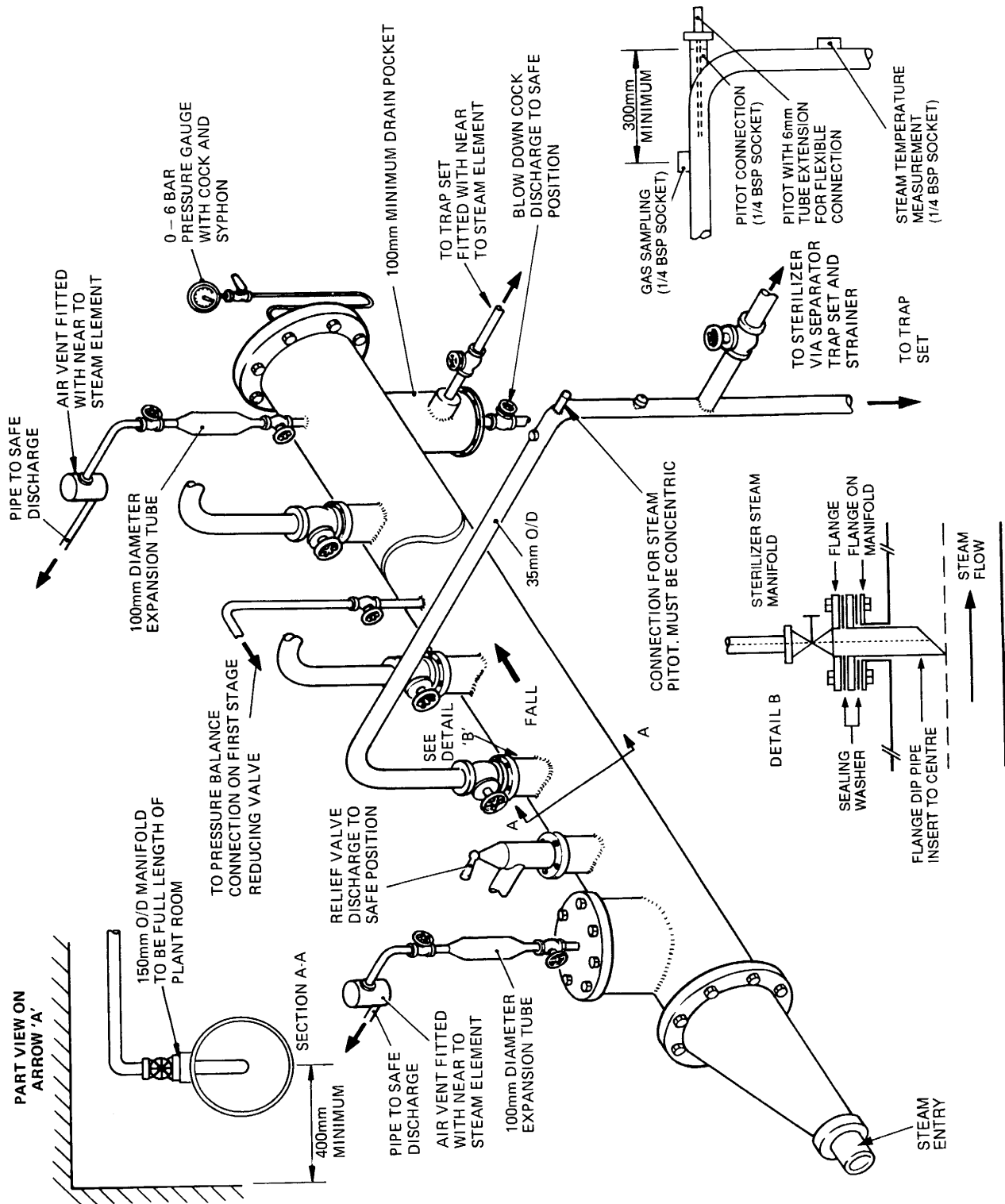



- 7.17 To meet the suggested purity standard for clinical sterilizers it will be necessary for parts in contact with steam entering the chamber to be constructed from low-carbon or stabilised stainless steel. However, in designing a steam service purchasers should bear in mind that the steam service (and indeed the sterilizer itself) may need to be upgraded within the life of the sterilizer and that compliance for steam purity may be achieved at that stage. Until the detailed implications of the Directives are known, it is recommended that steel and copper piping continue to be used, but that space be reserved in the plantroom for a mains steam conditioning unit. A space approximately 1.5 m square by 2.0 m high will accommodate a unit capable of supplying two 600 litre porous-load sterilizers.

Dryness

- 7.18 The dryness of the steam is of vital importance to the performance of any steam sterilizer. Excess moisture may cause damp loads in porous materials and uneven temperature distributions in non-porous loads, particularly those containing a large number of small items such as ampoules. When steam is required to be in direct contact with the surface to be sterilized, such as in porous-load sterilizers, sterilising conditions may not be attained if the moisture contained in the steam supply is insufficient to prevent the steam from becoming superheated when expanding into the chamber.
- 7.19 Steam dryness is traditionally characterised by a “dryness fraction”, but this is not appropriate for sterilizers because the method of measurement is difficult and requires a constant flow of steam. The low-volume sampling technique described in the steam dryness test (Part 3 of this SHTM) cannot be regarded as measuring a true dryness fraction because the sample is taken from the centre of the steam supply pipe and condensate flowing along the pipe wall is not collected. Consequently the term “dryness value” is used, where 1.0 represents dry, saturated steam. This method is used to determine whether performance problems could occur during testing and routine production. It is suitable for sterilizer installations because control valves and pipe services fitted to the sterilizer considerably reduce the amount of condensate entering the sterilizer chamber such that the sample has a similar amount of free condensate to the steam in the chamber.
- 7.20 European Standards require that sterilizers be designed to operate with steam having a dryness value of not less than 0.9 when measured in accordance with the steam dryness test described in Part 3 of this SHTM. For metal loads, the dryness value should not be less than 0.95. In practice, problems are unlikely to occur if the dryness value lies between 0.9 and 1.0, if it is reasonably constant and if the pressure reduction through the final pressure-reducing system is of the order two to one.



- 7.21 Although experience has shown that acceptable conditions are sometimes achieved when optimum conditions do not prevail, significant deviations are likely to cause the following problems:
- a. wet loads, resulting from too low a dryness value;
 - b. superheating, resulting from either too high a dryness value before the pressure-reducing system, or excessive pressure reduction through the valve (superheating may be severe if both conditions are present simultaneously);
 - c. difficulties with operation of the pressure-reducing system, resulting from a low pressure-reduction ratio, water hammer, water logging, dirt and other carry-over.

Excessive moisture

- 7.22 Excessive moisture, where droplets of water are present at the same temperature as that of the steam, will cause wet loads in porous-load sterilizers, low-temperature steam (LTS) disinfectors and LTSF sterilizers. It will reduce formaldehyde concentration in LTSF sterilizers and impair the efficacy of the process. Humidification may be impaired in EO sterilizers. Some causes of wet loads are as follows:

- a. steam pipes or manifolds may be incorrectly sloped and drained;
- b. the sterilizer may be supplied from an inadequately drained and vented “dead-leg” rather than a live steam main;
- c. the pipework between the boiler and the sterilizer may be insufficiently insulated, causing excessive condensation of the supply steam.

- 7.23 If wet steam continues to be a problem, “priming” may be occurring in the boiler, causing water droplets to be delivered in the steam. Modern compact and high rated boilers and steam generators are particularly sensitive to the quality of feed-water treatment and are much more likely to prime than boilers of traditional design. Priming or foaming (which results in carry-over of the boiler water) may be caused by any of the following:

- a. incorrect feed-water treatment;
- b. boiler water level being set too high;
- c. forcing a boiler which needs internal cleaning;
- d. violent boiling under fluctuating load conditions;
- e. a high level (typically 2000 ppm) of total dissolved solids.

Superheating

- 7.24 Superheated steam is an unsuitable medium for moist heat sterilization and can cause failure to sterilise, scorching of textiles and paper and rapid deterioration of rubber. Superheat conditions within the load and chamber may result from adiabatic expansion, exothermic reaction or both.
- 7.25 European Standards require that the superheat in free steam at atmospheric pressure should not exceed 25°C when measured by the superheat test described in Part 3 of this SHTM.
- 7.26 Superheating caused by **adiabatic expansion** is usually the result of an excessive reduction in pressure through a throttling device, such as a pressure-reducing system or a partially closed main steam valve. It is unlikely to be of significance in the circumstances normally encountered in hospital steam distribution systems, but superheating may arise if the main steam supply is dry, or the pressure is unusually high before the throttling device. This superheat can sometimes be avoided by the measures described in paragraph 7.12, which will reduce the dryness value of the steam at the inlet to the sterilizer pressure-reducing system. The reduced pressure ratio will minimise the effect of the expansion through it.
- 7.27 Superheating arising from **exothermic reaction** may occur during sterilization as a result of rehydration of exceptionally dry hygroscopic material. Methods of avoiding this are described in Part 4 of this SHTM.

Non-condensable gases

- 7.28 Non-condensable gases (NCGs) are defined as gases which cannot be liquefied by compression under the range of conditions of temperature and pressure used during the sterilization process. Low levels of NCGs contained in steam supplied to sterilizers can markedly affect the performance of the sterilizer and the efficacy of the process, cause chamber overheat and lead to inconsistencies in the performance of air detectors and failure of the Bowie-Dick test (see Part 3). The major NCGs are air and carbon dioxide.
- 7.29 British and European Standards require that sterilizers be designed to operate with steam having a fraction of NCGs not exceeding 3.5% by volume when measured by the method described in the non-condensable gas test (see Part 3).
- 7.30 The main source of NCGs in the steam supply is the boiler feed-water and the level will be greatly influenced by the water treatment employed. In some cases a study by a water treatment specialist will be necessary. The study should cover analysis of the water, venting and the blow-down regime required in order to ensure protection of the boiler against corrosion whilst minimising the entrainment of NCGs in the steam supply.



- 7.31 If anti-foaming agents and oxygen-scavenging agents (such as sodium sulphite) are used it is essential to ensure that the dosages are accurate.
- 7.32 Water-softening treatment is required to prevent the formation of scale. Except in hard water areas, a simple base-exchange system may be adequate in which bicarbonate ions are effectively converted into sludge-forming carbonates. This releases carbon dioxide into the water. A properly managed blow-down regime is essential to remove the accumulated sludge.
- 7.33 The most effective way of driving off dissolved air, carbon dioxide and other NCGs is by degassing the boiler feed-water before use by heating in a vented tank (a hot well). This will also break down bicarbonate ions, driving off further carbon dioxide. For the degassing to be effective, it is important that the temperature of the feed-water does not fall below 80°C at any time. The following measures should be adopted:
- pipework returning condensate to the hot well should be well lagged to keep the condensate hot;
 - the amount of cold make-up water in the hot well should at no time exceed 15% (the rest being returned condensate) since new water will both lower the temperature and introduce further NCGs;
 - the water in the well should be kept well mixed; this may be achieved by locating the feed-water inlet on the opposite side of the tank from the outlet, and by arranging for the feed-water to be “sparged” from the inlet through a number of small openings.
- 7.34 In very hard water areas the level of NCGs may still be high despite these measures, and dealkalisation treatment of the feed-water may then be necessary. In such cases the maintenance of high temperatures in the hot well is even more critical. Treatment with filming amines should be avoided since this method requires careful control and monitoring.
- 7.35 Users should note that, even with a well-designed system, the level of NCGs can be affected by competing demands on the steam service. For example, where a central steam boiler supplies both a sterilizer unit and a laundry through the same distribution system, the level of NCGs in the steam at the sterilizer may rise when the laundry demand is high. This is the result of an influx of cold make-up water into the hot well. Paradoxically, in some installations the NCG level may also rise when steam demand is low. In this case NCGs which would normally be removed by the laundry are being carried through to the sterilizer.



- 7.36 Some other causes of the presence of NCGs in the steam are as follows:
- a. the boiler may be priming (paragraph 7.23);
 - b. air may be being drawn into the system either through the boiler feed-pump glands or through a leak in the steam pipework between the boiler and the sterilizer;
 - c. steam pipework may be inadequately vented;
 - d. where NCGs are found in the sterilizer chamber during a production cycle:
 - (i) there may be an air leak into the chamber;
 - (ii) packaging materials, for example certain boxes, inks, adhesives, labels or trays, may be liberating gases. See Part 4 for guidance on packaging materials.

8. Porous-load sterilizers

Introduction

- 8.1 This chapter discusses specifications for clinical sterilizers designed to process porous items such as towels, gowns and dressings; and medical and surgical equipment, instruments and utensils that are packaged or wrapped in porous materials such as paper or fabrics. Clinical sterilizers using high-temperature steam to process porous loads are commonly known as “porous-load sterilizers”.
- 8.2 The guidance given here assumes that the sterilizer is to be used to process medical devices in compliance with the Standards discussed in Chapter 1.
- 8.3 Sterilization is achieved by direct contact of the load items with good-quality saturated steam at a preferred sterilization temperature of 134°C (see Table 4).
- 8.4 Porous-load sterilizers are distinguished from other high-temperature steam sterilizers by the following features:
- as porous loads trap both air and moisture, the sterilizer has a vacuum system to ensure that sufficient air is removed from the chamber and load before steam is admitted to the chamber. It also ensures that the pressure during the drying stage is sufficiently reduced so that the load is sensibly dry on completion of the cycle;
 - an air detector is fitted to the chamber to ensure that the plateau period cannot start until sufficient air has been removed from the chamber and load (see paragraph 8.7);
 - a heated jacket is generally used to prevent condensate from forming on the chamber walls and to assist drying of the load.

Standard specifications

- 8.5 Porous-load sterilizers should conform to the specifications in BS EN 285 and the safety specifications in BS EN 61010: Part 2-041.

Additional specifications

- 8.6 The following specifications are additional to those in BS EN 285 and permitted as options.



Air detector

- 8.7 BS EN 285 requires means to be provided to ensure that the requirement for steam penetration throughout the chamber and load is achieved for each cycle. The most reliable way to do this is to specify an air detector to ensure that the plateau period cannot commence if sufficient air and other non-condensable gases have not been removed from the chamber. The correct functioning of the air detector is crucial to the performance of the sterilizer.
- 8.8 Although an air detector is not required by BS EN 285, there is no other proven means of assuring that air is not present during production cycles. (The quantity of air sufficient to cause a failure of a sterilization cycle is small and for this reason the comparison of pressure and temperature within the chamber is by itself an unacceptable alternative.) An air detector is the most cost-effective way of ensuring that the sterilization conditions established during validation continue to apply.
- 8.9 If an air detector is not fitted, microbiological testing as described in BS EN 285 will be required, along with more frequent periodic testing and more demanding performance qualification. This option is expensive.

Port for air-flow metering device

- 8.10 A quarter-inch BSP port should be fitted on the side of the sterilizer, preferably towards the lower front, for the attachment of an air-flow metering device used for testing air-detector performance and chamber integrity (see Part 3).

Absolute pressure indicator

- 8.11 For leak-testing purposes an absolute pressure indicator (0 to 160 mbar) should be fitted, conforming to clause 6.2.2.2 of BS EN 285.

Bowie-Dick test cycle

- 8.12 Sterilizers for use in the NHS should be provided with a Bowie-Dick test cycle.

Extended drying

- 8.13 An additional cycle with extended drying time should be provided to process loads which are difficult to dry.

9. Fluid sterilizers

Introduction

- 9.1 This chapter discusses specifications for clinical sterilizers designed to sterilise aqueous fluids in sealed containers (normally bottles) of either glass or plastic. Such sterilizers are commonly known as “fluid sterilizers”.
- 9.2 The guidance given here assumes that the sterilizer is to be used to process medicinal products in compliance with the GGMP and EU Directives discussed in Chapter 1.
- 9.3 Sterilization is achieved by direct contact of the load items with a heating medium, normally good-quality saturated steam, and then by heat transfer through the container to increase and maintain the product at a preferred sterilization temperature of 121°C (see Table 4).
- 9.4 Fluid sterilizers are distinguished from other high-temperature steam sterilizers by the following features:
- a thermal door lock is fitted to ensure that when glass containers are being processed the door cannot be opened until the temperature inside all the containers has fallen below 80°C: this prevents the containers fracturing due to thermal stress;
 - operating cycles for plastic containers allow the door to be opened when the temperature inside the containers has fallen below 90°C: this prevents “blooming” of the containers;
 - cooling is usually by means of a water spray. The water may be either derived from steam condensate collected in the chamber or sterile water fed in from outside;
 - during all or parts of the cycle air may be introduced into the chamber to prevent large pressure differences arising between the inside and outside of containers; this is known as “pressure ballasting” (see paragraph 9.8).

Standard specifications

- 9.5 Fluid sterilizers intended for the sterilization of fluids in sealed rigid containers (glass bottles) should conform to the specifications in BS 3970: Parts 1 and 2 and the safety specifications in BS EN 61010: Part 2-041. See paragraph 9.8 for additional specifications for flexible (plastic) containers.
- 9.6 A European Standard for fluid sterilizers is being planned.

Additional specifications

- 9.7 The following specifications are in addition to those in BS 3970: Parts 1 and 2.

Cycle for plastic containers

- 9.8 Where the sterilizer is to be used to process plastic containers, a modified operating cycle may need to be specified. This is similar to the standard glass cycle but with the following modifications:

- a. pressure ballasting should be used to prevent pressure differences arising between the inside and the outside of containers sufficient to burst or distort them;
- b. the design pressure for the sterilizer chamber should be at least 10% higher than the allowable pressure; the operating pressure will typically be 3.3 bar gauge for a sterilization temperature of 121°C;
- c. the thermal door lock (9.4a) should be set so that the door cannot be opened until the temperature of the fluid in all the containers has fallen below 90°C.

- 9.9 If loads consisting solely of plastic containers are to be processed infrequently, then it may be better to specify a single cycle suitable for both glass and plastics (rarely used cycles may not be reliable). In that case the thermal door lock should be set so that the door cannot be opened until the temperature of the fluid in all the containers has fallen below 80°C.

Heat exchanger

- 9.10 The design of the coolant system should be such that, whenever a single fault occurs in the coolant system, the quality of all water in contact with the load complies with the requirements of the full-load test described in Part 3 of this SHTM. One example is a system whereby during any part of each operating cycle the primary coolant pressure is known to be less than the pressure external to each load container.

- 9.11 Connections for a pressure test gauge should be provided so that measurements can be made of:

- a. the pressure in the primary circuit;
- b. the differential pressure between the primary and secondary circuits.

Monitoring and control by F_0

- 9.12 F_0 is a measure of the “lethality” delivered to a load throughout an operating cycle, including the heating and cooling stages. It is expressed as a time in minutes equivalent to a continuous period at 121°C. Guidance on the use of F_0 is given in Part 4 of this SHTM and an extensive discussion of the theory and applications of F_0 can be found in Part 5.

- 9.13 F_0 may be used instead of the standard time - temperature relationships given in Table 4 to determine whether sterilization conditions have been achieved. When F_0 measured inside the load attains a certain value (normally 8 min or more) the load may be deemed to be sterile. It is particularly useful for heat-sensitive loads that can withstand the heat received during the prescribed holding time, but not the additional heat received during the heating and cooling stages, or for loads which would not survive a second operating cycle.
- 9.14 F_0 may be used either to monitor or to control an operating cycle:
- where monitoring is required, a recorder displays the accumulated F_0 throughout the operating cycle. This facility may be useful in borderline cases where the batch process record falls just outside the permitted tolerances established during performance qualification. Quality control procedures may then permit heat-sensitive products which would not survive resterilization to be released provided that the required F_0 has been attained;
 - where control is required, the holding time continues until the required F_0 is attained.
- 9.15 Sterilizers monitored by F_0 should be equipped with a load temperature probe to be inserted into the container of the load known to receive the lowest F_0 . The probe should be connected to a recorder displaying accumulated F_0 throughout the cycle.
- 9.16 Sterilizers controlled by F_0 should have at least two load-temperature probes to be inserted into two containers of the load known to receive the lowest F_0 . The probe showing the lowest accumulated F_0 at any instant should be used to control the cycle.
- 9.17 The recorder should display accumulated F_0 computed from the following equation:
- $$F_0 = \Delta t \sum_i \log_{10}^{-1} \left[\frac{T_i - 121}{10} \right]$$
- where:
- Δt = sampling interval;
 - T_i = temperature of sample i .
- 9.18 The sampling interval, Δt , should be not greater than two seconds.
- 9.19 The precision and accuracy of the measuring and computing equipment should be such that the performance requirements given in BS 3970: Part 2 can be met.
- 9.20 If an F_0 system is to be specified, then the responsibility is on the user to determine the nature of the bioburden in the load and also to determine that



the proposed cycle will ensure that the probability of survival of micro-organisms on any given load item does not exceed 10^{-6} . Guidance on how to do this is given in Part 4 of this SHTM.

- 9.21 Whenever F_0 is used either to control the operating cycle or to influence product release, it should be part of a complete quality assurance system and the validation and routine control subject to independent assessment by the licensing authority.
- 9.22 The GGMP (see paragraph 1.9) requires validation and control of equipment and processes. Any computer software used to determine the F_0 delivered to the product should also be validated and any modifications controlled.

10. Sterilizers for unwrapped instruments and utensils

Introduction

- 10.1 This chapter discusses specifications for clinical sterilizers designed to process unwrapped solid instruments and utensils intended for immediate use.
- 10.2 The guidance given here assumes that the sterilizer is to be used to process medical devices. However, these sterilizers do not meet the essential requirements of the EU Directives discussed in Chapter 1, which do not permit the supply of unpackaged sterile medical devices.
- 10.3 Sterilization is achieved by direct contact of the load items with good-quality saturated steam at a preferred sterilization temperature of 134°C (see Table 4).
- 10.4 Sterilizers for unwrapped instruments and utensils are distinguished from other high-temperature steam sterilizers by the following features:
- air is removed from the sterilizer by passive displacement, either downward or upward depending whether the steam is supplied externally or generated internally. These sterilizers should therefore not be used to process either wrapped instruments and utensils or unwrapped instruments and utensils with narrow lumens which could inhibit the removal of air and the penetration of steam. Such items should be processed in a porous-load sterilizer (see Chapter 8);
 - except where vacuum is used to dry the load (normally in larger, fixed sterilizers), the load is partially dried by natural evaporation after it has been removed from the chamber;
 - since the sterilized items are exposed to the air on being removed from the chamber, they are susceptible to rapid recontamination. These sterilizers are therefore suitable for clinical use only within the immediate environment in which the load items are to be used.
- 10.5 Where practicable, instruments and utensils should be wrapped and processed in a porous-load sterilizer.
- 10.6 Sterilizers for unwrapped instruments and utensils may either be transportable or fixed.

Transportable sterilizers

- 10.7 The majority of sterilizers are transportable (bench-top) models which are electrically heated, requiring only a 13 A socket outlet and no piped services. They are commonly used in theatre suites where there is no SSD service and in primary health care units, such as GP and dental practices.
- 10.8 Steam is generated within the sterilizer chamber and a supply of distilled, deionised or reverse-osmosis water is required. Tap water should not be used as it may cause scaling and chlorine dissolved in the water may corrode the chamber.
- 10.9 Certain machines, known as “flash” sterilizers, operate at 150°C with a holding time of a few seconds. Although they are intended for rapid sterilization of unwrapped instruments and utensils, the time saved in sterilization is lost in waiting for the load to cool. They do not conform to BS 3970 (see paragraph 10.11) and their use is not recommended.

Fixed sterilizers

- 10.10 Fixed sterilizers are generally discouraged, but may be installed in an operating theatre to replace existing fixed sterilizers where supply from a porous-load sterilizer is impracticable.

Standard specifications

- 10.11 Transportable sterilizers for unwrapped instruments and utensils should conform with the specifications in BS 3970: Parts 1 and 4 and the safety specifications in BS EN 61010: Part 2-041. A European Standard on “small” sterilizers (less than one module) is under development and will eventually supersede the relevant clauses of BS 3970.
- 10.12 Fixed sterilizers should meet the performance requirements of BS 3970: Parts 1 and 4.

Additional specifications

- 10.13 The following specifications are permitted as options to those in BS 3970: Parts 1 and 4.

Operating cycle

- 10.14 A transportable sterilizer should have a single operating cycle. Option A of BS 3970: Part 4 (134-138°C) is recommended for NHS use. Some sterilizers may be equipped to provide other optional operating cycles, specified by the purchaser, but the selection of the cycle should be by means of a key, code or tool not available to the operator.



Temperature recorder

- 10.15 A temperature recorder is optional in BS 3970: Part 4 but is recommended where documented evidence of correct functioning is required.

11. Dry-heat sterilizers

Introduction

- 11.1 This chapter discusses specifications for clinical sterilizers designed to sterilise load items by exposure to hot, dry air. Such sterilizers are correctly known as “dry-heat sterilizers” and sometimes as “hot-air sterilizers” or “sterilising ovens”. They are intended to process materials such as oils, powders and some ophthalmic instruments, which can withstand high temperatures but are likely to be damaged or not sterilized by contact with steam.
- 11.2 The guidance given here assumes that the sterilizer is to be used to process either medicinal products or medical devices in compliance with the EU Directives discussed in Chapter 1.
- 11.3 Sterilization is achieved by direct contact of the load items with hot, dry air at a preferred sterilization temperature of 160°C (see Table 4).
- 11.4 Purchasers should be aware that, owing to the low thermal conductivity of air, it is difficult to obtain an even temperature distribution within the chamber and heat transfer from the air to the load can be very slow. A complete cycle, including assisted cooling to 80°C, takes approximately five hours for a full test load as described in Part 3 of this SHTM.
- 11.5 Dry-heat sterilizers are not suitable for use as drying cabinets (see BS 2648 for specifications for drying cabinets).

Standard specifications

- 11.6 The only British Standard covering dry-heat sterilizers was BS 3421: 1961, which has long been inadequate and is now withdrawn. There are no immediate plans for future British or European Standards covering dry-heat sterilizers. In the absence of a current standard, dry-heat sterilizers should conform to Model Engineering Specification C14 published by NHS Estates and to the safety specifications in BS EN 61010: Part 2-043.



Additional specifications

- 11.7 The GGMP requires dry-heat sterilizers to have the following characteristics:
- a. air should be circulated within the chamber to promote a uniform temperature distribution;
 - b. positive pressure should be maintained inside the chamber to prevent the entry of non-sterile air;
 - c. any air admitted to the chamber should be passed through a bacteria-retentive filter.

12. Low-temperature steam disinfectors and low-temperature steam and formaldehyde sterilizers

Introduction

- 12.1 This chapter discusses specifications for clinical disinfectors and sterilizers designed to process heat-sensitive items (wrapped or unwrapped) which will withstand saturated steam at temperatures up to 80°C.
- 12.2 The guidance given here assumes that the sterilizer is to be used to process medical devices in compliance with the EU Directives discussed in Chapter 1. Low-temperature steam and formaldehyde (LTSF) is not listed in the GGMP as a suitable method for sterilization of medicinal products.
- 12.3 Disinfection is achieved by the direct contact of the load items with good-quality saturated steam at a disinfection temperature of 71°C at sub-atmospheric pressure (“LTS disinfectors”). Sterilization is achieved by contact with both saturated steam and formaldehyde gas (“LTSF sterilizers”). Sterilizers designed for LTSF will normally incorporate an LTS disinfection cycle.

NOTE: Despite their name, LTSF sterilizers are disinfectors.

- 12.4 Formaldehyde is a toxic gas. Exposure to formaldehyde is controlled by the COSHH Regulations 1999 and subject to the maximum exposure limits detailed in Table 1. Operational safety information is given in Part 4 of this SHTM.
- 12.5 LTS disinfectors and LTSF sterilizers operate for the whole of the cycle with the chamber pressure below atmospheric pressure. An air leak rate which is too small to affect the efficacy of a porous-load process may in the case of LTS and LTSF cause an unacceptable volume of air to enter the chamber. Air detectors currently available cannot reliably detect at negative pressures, so as an alternative manufacturers now include a vacuum leak monitor, set to fail the cycle at a leak rate not exceeding 5.2 mbar min⁻¹ (see the vacuum leak monitor test in Part 3 of this SHTM). A vacuum leak monitor is less effective than an air detector.
- 12.6 Since the sterilization process is ultimately dependent on chemical action, microbiological test methods are required to confirm that sterilization conditions have been attained (see Part 3).
- 12.7 LTSF sterilizers require special precautions for ventilation and drainage (see Chapter 6).

Standard specifications

- 12.8 LTS disinfectors (or LTSF sterilizers with an LTS cycle) should conform to the specifications in BS 3970: Parts 1 and 5. LTSF sterilizers should conform to the specifications in BS 3970: Parts 1, 5 and 6 and the safety specifications in BS EN 61010: Part 2-042.
- 12.9 No European Standards are currently planned for LTS disinfectors or LTSF sterilizers.

Additional specifications

- 12.10 The following specifications for LTSF sterilizers are in addition to those given in BS 3970: Parts 1 and 6.

Room ventilation

- 12.11 The sterilizer manufacturer should supply the appropriate interfaces to enable the sterilizer to function with the room ventilation system as described in Chapter 6.

Local exhaust ventilation

- 12.12 LTSF sterilizers should be connected to a local exhaust ventilation system (LEV) to ensure that the emission of formaldehyde gas into the atmosphere does not present a safety hazard. The sterilizer manufacturer should supply the appropriate hoods and interfaces to enable the sterilizer to function with the LEV system as described in Chapter 6.

Formalin supply

- 12.13 The formalin reservoir within LTSF sterilizers should be installed in a sealed, recessed enclosure protected from mechanical damage. The means of attachment of the reservoir should minimise the possibility of spillage. The top of the reservoir should be no more than 1.5 m above floor level.
- 12.14 An indicator, visible from the front of the sterilizer, should show:
- how much formalin has been used in the current cycle;
 - how much formalin remains in the reservoir.

Degassing facilities

- 12.15 A space or room should be allocated for the aeration and storage of processed loads. Load items do not normally absorb formaldehyde and providing the gas removal is satisfactory, the load may be placed in the downstream part of the ventilation flow in a designated area of the finished goods store.



Gas monitoring system

- 12.16 Gas detectors should be placed wherever there is a risk of people being exposed to formaldehyde. Such places would normally include both the loading area and plantroom. The detectors should be placed close to the normal working positions of personnel. The monitoring system should be set to sound a visual and audible alarm when the atmospheric concentration of formaldehyde exceeds a preset level no greater than the short-term maximum exposure limit specified in Table 1.
- 12.17 Interfaces with the ventilation systems will also be required as discussed in Chapter 6.

13. Ethylene oxide sterilizers

Introduction

- 13.1 This chapter discusses specifications for clinical sterilizers designed to sterilise load items by exposure to ethylene oxide gas. Such sterilizers are commonly known as “ethylene oxide sterilizers” or “EO sterilizers”.
- 13.2 The guidance given here assumes that the sterilizer is to be used to process medical devices in compliance with the EU Directives discussed in Chapter 1.
- 13.3 EO is a highly reactive liquid and gas which is toxic, flammable and explosive. Exposure to EO is controlled by the COSHH Regulations 1999 (see Chapter 1). The safe operation of EO sterilizers requires careful consideration of all aspects of the installation and operation of equipment. Operational safety information is given in Part 4 of this SHTM.
- 13.4 EO sterilizers should be installed in dedicated areas which are not used for any other working purposes.
- 13.5 An EO sterilization process may include preconditioning and degassing procedures requiring additional equipment. Further information about preconditioning is given in paragraph 13.21 and about degassing in paragraph 13.35.
- 13.6 EO sterilizers have the potential to cause serious environmental pollution. Large sterilizers will require additional plant to dispose safely of exhaust products and this will add considerably to the cost. Such plant is described in paragraph 13.39. Precautions in ventilation and drainage systems are outlined in Chapter 6.
- 13.7 Since the sterilization process is ultimately dependent upon chemical action, microbiological test methods are required to confirm that sterilization conditions have been attained. These are described in Part 3 of this SHTM.
- 13.8 Purchasers of an EO sterilizer should be aware of the following points:
- a. the difficulty in validating and monitoring suitable cleaning processes for loads before they are sterilized (see Part 4);
 - b. the difficulty in carrying out representative performance qualification tests for the wide variety of loading conditions that may be used (see Part 3);
 - c. the difficulty in carrying out meaningful bioburden studies on small numbers of widely differing devices to be sterilized (see Part 4);

- d. the problems associated with determining the levels of residual EO and its reaction products when small numbers of widely differing devices are processed (see Part 3);
 - e. the need for specialist technical resources dedicated to the operation and maintenance of the equipment (see Part 4).
- 13.9 EO installations can be expensive both to buy and to run. As there are few items which need to be sterilized by EO, their provision cannot normally be justified by individual hospitals. Where there is a clear need for EO sterilization, the service should be run by a well-supported specialist unit where microbiological testing, environmental controls, degassing procedures and evaluation of residual EO in the sterilized product can be assured.

Types of sterilizer

- 13.10 Two types of EO sterilizer are suitable for NHS use.

Low-pressure sterilizers

- 13.11 These are small sterilizers, of chamber volumes around 150 litres, where the sterilant is pure EO at sub-atmospheric pressure. The gas is supplied from a single-use, disposable cartridge contained within the chamber. The cartridge limits the amount of EO in use at any one time and reduces the toxic and explosive hazards. The chamber is designed to contain the effects of an explosion of the contents of a single cartridge.
- 13.12 Low-pressure sterilizers are relatively cheap to install and to run, requiring no piped EO service and no gas disposal plant. The low pressure in the chamber allows pressure-sensitive equipment to be processed safely.

High-pressure sterilizers

- 13.13 These are large sterilizers, of chamber volume up to 500 litres, where the sterilant is EO diluted with another gas, supplied from cylinders.
- 13.14 The mixtures are chosen to expose the load to an EO concentration of around 500-1000 mg litre⁻¹ while keeping the potential hazards to a minimum. Two gas systems are in common use:
- a. EO with chlorofluorocarbons (CFCs) at pressures up to 2 bar: CFCs have traditionally been used as a diluent gas but are no longer acceptable for environmental reasons;
 - b. EO with carbon dioxide at pressures up to 6 bar.
- 13.15 Because of their larger size, high-pressure sterilizers require gas disposal plant to remove EO from the chamber exhaust (see paragraph 13.39).

Standard specifications

- 13.16 EO sterilizers should conform to the specifications in BS EN 1422 and the safety specifications in BS EN 61010: Part 2-042. Two types of sterilizer are specified:
- type A** sterilizers have operating cycles programmable by the user and may have very large chamber volumes; they are intended primarily for use in industry;
 - type B** sterilizers have one or more preset operating cycles; the chamber volume is no greater than 1000 litres.
- 13.17 EO sterilizers for use in the NHS should conform to Type B. They may be either low-pressure or high-pressure systems (see paragraph 13.10).

Additional specifications

- 13.18 The following specifications for EO sterilizers are in addition to those given in BS EN 1422.

Room ventilation

- 13.19 The sterilizer manufacturer should supply the appropriate interfaces to enable the sterilizer to function with the room ventilation system as described in Chapter 6.

Local exhaust ventilation

- 13.20 EO sterilizers should be connected to a local exhaust ventilation system (LEV) to ensure that the emission of EO gas into the atmosphere does not present a safety hazard. The sterilizer manufacturer should supply the appropriate hoods and interfaces to enable the sterilizer to function with the LEV system as described in Chapter 6.

Preconditioning facilities

- 13.21 For successful sterilization the load should be at a predetermined temperature and humidity before the start of the operating cycle. This may be achieved by exposing the load to the required conditions in an environmentally controlled room or chamber. This preconditioning procedure is considered an integral part of the sterilization process. See Part 4 for more information about routine preconditioning.
- 13.22 Preconditioning requires either a chamber (designed to accommodate one sterilizer load) or a room (two or more loads).



- 13.23 Humidification should be by direct injection of low-pressure steam and should be controlled by direct measurement of relative humidity (RH) within the chamber or room. Humidifiers which operate by dispersion of water into an aerosol (such as spinning-disk humidifiers or nebulizers) are potent sources of microbial contamination and should not be used.
- 13.24 Provision should be made for continuous monitoring and recording of temperature and RH at locations determined as being representative of the conditions prevailing throughout the chamber or room.
- 13.25 The temperature and RH at which the chamber or room is controlled should be compatible with the conditions prevailing during the sterilizer operating cycle. They should be selected so that the temperature and RH of the load going into the sterilizer are neither so low that problems of long heat-up and condensation occur, nor so high that temperature control of the cycle is compromised. The uniformity of conditions should be established during validation.

Preconditioning chamber

- 13.26 All internal surfaces should be smooth, impermeable, durable and easily cleanable. Wherever possible internal corners should be rounded with a minimum radius of 25 mm.
- 13.27 Chambers constructed of metal should be of stainless steel, mild steel clad with stainless steel or nickel, or anodised aluminium. Alternatively, metal surfaces may be treated to inhibit corrosion.
- 13.28 The chamber should have assisted air circulation designed to provide effective airflow around all load items (whether partly or fully loaded) and to maintain uniform temperature and humidity throughout the chamber. Air entering the chamber should be filtered.
- 13.29 Door interlocks should be provided so that after the door has been closed it cannot be opened until the preset preconditioning time has elapsed.

Preconditioning room

- 13.30 The room should be segregated from assembly and packaging areas but located close to the sterilizer loading area to permit rapid transfer of the load.
- 13.31 Consideration should be given to cleanliness and ease of cleaning, especially in the design and location of equipment. The room should have a standard of finish similar to that of environmentally controlled areas. All internal surfaces should be smooth and free from cracks. Surface finishes should be impermeable, durable and easily cleanable. Ledges should be kept to a minimum. Wherever possible, internal corners should be rounded with a minimum radius of 25 mm. Any services required for cleaning should be provided within the room.



- 13.32 Corrosion of metal components may be a problem in the high-humidity conditions prevailing in the room. Uncoated metal surfaces should be either stainless steel or anodised aluminium.
- 13.33 The room should have assisted air circulation designed to provide effective airflow around all load items (whether the room is partly or fully loaded) and to maintain uniform temperature and humidity throughout the room. Air recirculation should incorporate a filtration system.
- 13.34 The door should be fitted with an audible and visual alarm set to operate if the door is left open for more than the time for which the conditions in the room can be maintained. This time should be established during validation (see Part 3 of this SHTM).

Degassing facilities

- 13.35 Most, if not all, materials subject to EO sterilization retain varying amounts of EO gas. The residual EO in medical devices must be reduced to a safe level, both for personnel handling the product and for the patient. The general term for this procedure is aeration. Aeration within the operating cycle is known as flushing. Aeration following the operating cycle is known as degassing.
- 13.36 Other compounds may also be present as reaction products of EO, for example ethylene chlorhydrin, and the concentration of these will also need to be reduced. Reference in this SHTM to reduction of EO concentration should be read as applying equally to any other toxic reaction products which may be present.
- 13.37 Reduction of residual EO occurs naturally as gas diffuses from the product into the surrounding air. Under normal ambient conditions this process may be very slow and significant amounts of EO may be released into the environment. For these reasons degassing by storage under ambient conditions is not recommended. Mechanical degassing should be used.
- 13.38 A degassing facility may be either a purpose-made aeration cabinet or a room. Some sterilizers incorporate an additional flushing stage as part of the operating cycle and this may be sufficient. Within the NHS the volume of product and the number of cycles a week will be small; for most installations a separate aeration cabinet is not normally necessary.

Disposal of EO

- 13.39 When an EO sterilizer is purchased consideration must be given to the method to be used to dispose of gases exhausted from the chamber. For a low-pressure sterilizer, chamber exhaust ventilation as described in Chapter 6 is adequate. For high-pressure sterilizers, however, the quantity of EO is likely to be too high to be disposed of safely without further processing.



- 13.40 Five basic methods are available: water scrubbing, incineration, catalytic oxidation, reclamation and EO absorption and modification. Of these, catalytic oxidation is recommended for use in the NHS.
- 13.41 Catalytic oxidation oxidizes EO to carbon dioxide and water by heating the exhaust gases in the presence of a catalyst at a temperature of approximately 300°C. Maximum efficiency is in excess of 99%.
- 13.42 Inlet gas streams must be diluted to contain less than 1% EO to prevent significant heating of the catalyst bed. High EO concentrations may cause a runaway reaction and under these conditions, in addition to the fire and explosion hazard, any CFCs present in the gas may be degraded to give toxic products such as phosgene.
- 13.43 The purchase and running costs are moderate to high. Little routine maintenance is required other than periodic replacement of the catalyst bed.
- 13.44 Small units suitable for installation with small EO sterilizers are commercially available and present few installation problems.

Gas monitoring system

- 13.45 Gas detectors should be placed wherever there is a risk of people being exposed to EO. Such places would normally include the loading area, plantroom, manifold room and degassing room. The detectors should be placed close to the normal working positions of personnel. The monitoring system should be set to sound a visual and audible alarm when the atmospheric concentration of EO exceeds a preset level no greater than the short-term maximum exposure limit specified in Table 1.
- 13.46 Interfaces with the ventilation systems will also be required as discussed in Chapter 6.

14. Laboratory sterilizers

Introduction

- 14.1 This chapter discusses specifications for sterilizers (“laboratory sterilizers”) used for the processing of materials and equipment to be used in clinical laboratories.
- 14.2 These sterilizers are not intended for the processing of medical devices or medicinal products. There is therefore no need for them to comply with the EU Directives discussed in Chapter 1.
- 14.3 Guidance on validation and periodic testing of laboratory sterilizers is given in Part 3 of this SHTM. Guidance on operation is given in Part 4.

Provision of laboratory sterilizers

- 14.4 The HSE Advisory Committee on Dangerous Pathogens recommends that laboratory sterilizers capable of making safe infected material be provided as shown in Table 11.

Table 11: Provision of laboratory sterilizers

Containment level	Provision
1	No sterilizers are required
2	A sterilizer with a make-safe cycle must be readily accessible, normally in the same building as the laboratory
3	A sterilizer with a make-safe cycle should be preferably situated within the laboratory, but one must be readily accessible in the laboratory suite
4	A double-ended sterilizer with interlocking doors with entry in the laboratory and exit in a clean area must be provided

Source: *Categorisation of pathogens according to hazard and categories of containment* (4th edition), HSE 1995.

- 14.5 General information on the requirements for the four containment categories can be found in the HSE document *Categorisation of pathogens according to hazard and categories of containment*, published by HMSO. Purchasers should note that the containment requirements have been given statutory force by the Control of Substances Hazardous to Health Regulations 1999.
- 14.6 Sufficient sterilizers should be installed to ensure that contaminated material can continue to be made safe if any sterilizer is removed from service. A cycle for the make-safe of small plastic discard (see paragraph 14.38) and a cycle for the make-safe of contained fluid discard (see paragraph 14.42) should be available at all times. The need for other cycles to be duplicated

will depend on the nature and volume of the work being done in the laboratory.

- 14.7 Where possible, at least one sterilizer should be designated solely for the processing of discard material.
- 14.8 Laboratory sterilizers intended to process discard material should be sited as close as possible to the area in which the discard is produced, to avoid contaminated material being transported through rooms where it would not normally be stored or handled. Laboratory sterilizers intended to process culture media should be directly accessible from the media preparation area.
- 14.9 The preferred type of sterilizer is a front-loading unit, recessed into a panel separating the loading area from the plantroom, as described in Chapter 5. Such sterilizers are available with a wide range of chamber sizes and operating cycles.
- 14.10 Sterilizers with a door at each end are essential for Containment Level 4 laboratories, though they present special problems of installation and access for maintenance.
- 14.11 Free-standing machines, with chambers up to 500 litres, are also available. They are either top-loading or front-loading. For top-loading sterilizers, where there may be difficulties in load handling and lifting and a hazard from hot surfaces, the practical limit is 250 litres. Multiple free-standing sterilizers are not normally cost-effective when used in centralised sterilising facilities.
- 14.12 Transportable sterilizers, which generate steam from an internal reservoir, may be appropriate for small laboratories.

Design considerations

- 14.13 A laboratory sterilizer may provide one or more operating cycles, each designed for processing a particular type of load. The number and nature of the operating cycles which can be supported by any particular machine will depend on details of its design and construction. It will depend in particular on the methods used to remove air from the chamber and load, the methods used for cooling and drying the load and the provision of thermal door locks. Purchasers should carefully consider which operating cycles they are likely to need in the future, so that the manufacturer can install the necessary hardware. Otherwise it may not be possible to add a new operating cycle to a sterilizer without expensive modification. It is not merely a matter of "reprogramming."
- 14.14 The following three considerations are crucial. The cycles themselves are described in paragraphs 14.36-14.55.



Air removal

- 14.15 Laboratory sterilizers commonly employ one of two principles for removing air from the chamber, each of which can be implemented in several ways:
- a. **passive:** steam comes in at the top of the chamber and air is forced out at the bottom (downward displacement). This is the simpler (and cheaper) method, but only suitable for loads such as sealed bottles which do not impede the removal of air from the chamber. (In certain machines, notably transportables, passive air removal may be by upward displacement.)
 - b. **active:** the chamber is subjected to successive pressure changes to draw air from the chamber. This is required for loads such as fabrics, glassware and other equipment where trapped air cannot reliably be removed by passive methods. The more difficult air is to remove, the more pressure pulses will be required. Active air removal is always faster than passive methods.

Cooling and drying

- 14.16 Where necessary, one of four cooling methods may be used:
- a. **natural:** the load is allowed to cool naturally in the chamber until it reaches a safe temperature. This is the cheapest option and acceptable if lengthy cycle times are tolerable and the load is not likely to be damaged by remaining hot for long periods;
 - b. **dry assisted:** either cold water is circulated through the jacket or through cooling coils, or air is circulated through the chamber (with or without pressure pulsing) to accelerate the cooling process. This is faster than natural cooling;
 - c. **wet assisted:** the load is sprayed or deluged with coolant water. This is faster than dry assisted cooling, therefore the method of choice for products which cannot withstand long periods at high temperature, but is only acceptable for loads such as sealed bottles where the coolant cannot come into contact with the contents. It is not suitable for loads contained in discard boxes;
 - d. **vacuum:** the chamber is evacuated to permit the remaining heat in the load to evaporate moisture, simultaneously cooling and drying the load. This is suitable for loads which trap moisture (in general these are the same as the loads which trap air).

Thermal door locks

- 14.17 Laboratory sterilizers constructed to BS 2646 will have one or two door locks designed to prevent the door from being opened until the load cools to a preset temperature:
- a. all sterilizers will have an interlock that prevents the door from being opened until the temperature of any fluid in the chamber and load (including condensate) has fallen below the boiling point of water at local atmospheric pressure (100°C at sea level);
 - b. sterilizers designed to process discard and fluid loads (cycles for make-safe of discard in large containers, sterilization of culture media, and free steaming) will have an additional interlock (a “thermal door lock”) to ensure that the door cannot be opened until the temperature of fluid in sealed containers has fallen below 80°C (see paragraph 14.26 for additional specifications). Note that this requirement will considerably lengthen the cycle time.

Standard specifications

- 14.18 Specification of laboratory sterilizers is covered by the various parts of BS 2646, *Autoclaves for sterilization in laboratories*, which has been radically revised in recent years:
- Part 1: 1993 - Specification for design, construction and performance;
 - Part 2: 1990 - Guide to planning and installation;
 - Part 3: 1993 - Guide to safe use and operation;
 - Part 4: 1991 - Guide to maintenance;
 - Part 5: 1993 - Methods of test for function and performance.
- 14.19 While BS 2646 is a sound basic specification for laboratory sterilizers, the UK Health Departments recommend additional specifications which are detailed in paragraphs 14.23-14.34.
- 14.20 Laboratory sterilizers constructed in accordance with BS 2646 will not be suitable for processing material infected with Hazard Group 4 pathogens unless provision is made to contain and sterilise all chamber effluents before disposal. Such a sterilizer should not be operated without a full fault-and-effect analysis to ensure that the containment remains secure if a failure occurs. The advice of the Public Health Laboratory Service or the NHS in Scotland Management Executive should be sought before specifying a sterilizer for a Containment Level 4 laboratory.
- 14.21 BS 2646 does not cover culture media preparators. A UK Health Departments specification for these is discussed in paragraph 14.56.
- 14.22 A European Standard on laboratory sterilizers is in preparation but is unlikely to be published in the near future.

Additional specifications

- 14.23 The following specifications are additional to those required by BS 2646: Part 1. Purchasers should ensure that they are agreed with the manufacturer before any contract is made.

Instruments and controls

- 14.24 BS 2646: Part 1: 1993 requires only that sterilizers be fitted with a chamber temperature indicator and a chamber pressure indicator. Laboratory sterilizers for use in the NHS must have a temperature recorder and a pressure recorder, complying with the requirements of BS 3970: Part 1.
- 14.25 A cycle counter complying with BS 3970: Part 1 will also be required.

Thermal door-lock override

- 14.26 Where the sterilizer is provided with a thermal door lock designed to prevent the door being opened until the temperature of fluids in sealed containers has fallen to 80°C (14.17b), a means should be provided to override the lock during the cooling stage of the operating cycle. The override is intended for use by trained persons who wish to gain access at temperatures above 80°C to loads which will not present an explosive hazard.
- 14.27 The override should meet the following specifications:
- the override switch is accessible only by means of a key, code or tool unique to the sterilizer;
 - it operates only during the cooling stage of the cycle and causes the cooling stage to terminate;
 - there is a visual indication that the override has been operated;
 - the switch resets automatically when released;
 - at the end of the cycle the door cannot be opened except by means of a key, code or tool.
- 14.28 Where the sterilizer is intended to be used exclusively for the make-safe of discard in small containers, compliance with paragraphs 14.27d and 14.27e may be waived with the agreement of the laboratory safety officer. In this case, the switch should reset automatically whenever a different operating cycle is selected or whenever the power supply is interrupted.

Load-temperature probe

- 14.29 Where the sterilizer is to be used with cycles other than the make-safe of discard, a load-temperature probe should be provided within the chamber. This is a temperature sensor attached to a flex and designed to be inserted into load items (such as bottles) to monitor the temperature during an operating cycle. The reading is displayed on a temperature recorder as described in paragraph 14.24. Means should be provided to stow the probe in a safe position within the chamber when it is not in use.

Steam generators

- 14.30 Where steam is supplied from a generator within the sterilizer (Types 2 and 3 of BS 2646: Part 1: 1993), condensate from the steam which comes into contact with any discard load should not be returned to the boiler.
- 14.31 Where the sterilizer chamber is used as a water reservoir (Type 4), the water should enter the chamber after the start of the cycle and be drained before the end of the cycle.
- 14.32 Reservoirs may accumulate solidified agar and should be designed so that they can be cleaned easily.

Chamber drain

- 14.33 The chamber drain should be designed to minimise the risk of its becoming blocked with solidified agar or similar material.
- 14.34 Where the temperature of the effluent is high, for example for free steaming, means should be provided to prevent vapour being discharged into the plantroom or the loading area. Further information on drainage may be found in Chapter 6.

Top-loading sterilizers

- 14.35 Top-loading sterilizers are difficult to load safely without the use of mechanical aids. Loading systems should be designed to protect the operator from the risk of injury caused by lifting and hot surfaces and should comply with the requirements of the Manual Handling Operations Regulations 1992 and the Lifting Operation and Lifting Equipment Regulations 1998 (see Chapter 4 and Part 1 of this SHTM).



Operating cycles

- 14.36 BS 2646 recognises only three distinct operating cycles which it denotes as make-safe, liquids sterilization, and equipment and glassware sterilization. The range of operating cycles recommended for NHS use, and the materials they are designed to process, are described below and specified in Table 12. Where the table gives a choice of sterilization temperatures, the highest temperature should normally be specified. The performance class listed for each cycle is explained in Table 5. If heat-sensitive loads are likely to be processed, then additional lower-temperature cycles may be required. The complete set of cycles to be provided on each machine, including any non-standard cycles not shown here, should be agreed with the manufacturer before the contract is placed.



Table 12: Operating cycles for laboratory sterilizers

Name of operating cycle	Thermal door lock(80°C)	Air-removal method	Cooling and drying method	Sterilization temperature [°C] ^a	Typical performance class ^b
Make-safe of small plastic discard	Yes	Active	None	134	5
				126	6
				121	6
		Passive	None	134	9
				126	9
				121	9
Make-safe of contained fluid discard	Yes	Passive	Natural	134	12
				126	12
				121	12
			Dry assisted	134	9
				126	9
				121	9
Sterilization of culture media (pre-set cycle)	Yes	Passive	Natural	121	12
				115	12
				Dry assisted	121
			Wet assisted	115	9
				121	5
				115	6
Sterilization of culture media (variable cycle)	Yes	Passive	Dry assisted	102 - 134	10
Disinfection of fabrics	No	Active	None	134	3
				126	4
				121	5
Sterilization of glassware and equipment	No	Active	Vacuum	134	3
				126	3
				121	4
		Passive	None	134	4
				126	5
				121	6
Free steaming (variable cycle)	Yes	Passive	Dry assisted	102 - 104	10

These are the most common combinations for operating cycles. Others are possible.

^a See Table 4 for full sterilization conditions.

^b See Table 5 for definitions of performance classes.



- 14.37 Operating cycles are normally automatic and preset and cannot be adjusted by the operator. For some processes, however, such as the sterilization of culture media and free steaming, it may be desirable to have a variable cycle with controls for adjusting the sterilization temperature and holding time within a preset range. This feature should normally be provided as a separate cycle.

Make-safe of small plastic discard

- 14.38 This cycle corresponds to the “make-safe” cycle specified in BS 2646. It is designed to sterilise infected material held in plastic containers not exceeding 50 ml. Examples of such containers include Petri dishes, specimen bottles and other small plastic items intended either for disposal or for reuse.
- 14.39 Although the containers would normally be unsealed, the limits on volume ensure that any fluid held in a sealed container does not present an explosion hazard when the door is opened at the end of the cycle. Glass containers and larger plastic containers should be processed with the make-safe cycle for contained fluid discard (paragraph 14.42).
- 14.40 If the workload is heavy, an active air removal system (paragraph 14.15b) is recommended to shorten the cycle time.
- 14.41 Discard boxes as specified in paragraph 14.60 will be required.

Make-safe of contained fluid discard

- 14.42 This cycle is a variant of the “liquids sterilization” cycle specified in BS 2646. It is designed to make-safe infected material in sealed glass containers of any size or sealed plastic containers of volume greater than 50 ml.
- 14.43 While essentially the same as the culture media cycle (paragraph 14.45), a sterilization temperature of 126°C is normally used to protect the glass. Lower sterilization temperatures should only be used if plastic containers are to be processed.
- 14.44 Discard boxes as specified in paragraph 14.60 will be required.

Sterilization of culture media

- 14.45 This cycle is a variant of the “liquids sterilization” cycle specified in BS 2646. It is designed to sterilise culture media in open or sealed containers.
- 14.46 Since culture media are normally damaged by sterilization at 134°C the maximum sterilization temperature is set at 121°C.
- 14.47 A variable cycle, in which combinations of sterilization temperature and holding time can be set by the operator, may be desirable for certain products and, if required, should be specified as a separate cycle.



- 14.48 The culture media cycle is also suitable for disinfecting unwrapped equipment such as tubing sets.

Disinfection of fabrics

- 14.49 This cycle is a variant of the “glassware and equipment” cycle specified in BS 2646. It is designed to disinfect (but not sterilise) fabric materials such as towels, clothing, wrapped animal bedding, and other porous materials.
- 14.50 If the fabrics are required to be sterile and dry at the end of the cycle, a machine complying with the performance requirements for a clinical porous-load sterilizer will be necessary (see Chapter 8).
- 14.51 The cycle differs from the glassware and equipment cycle (14.53) in that more pressure pulses will be required to remove air from the load.
- 14.52 The fabrics cycle is also suitable for sterilising empty glassware without caps and for disinfecting wrapped tubing and wrapped filters (see paragraph 14.54).

Sterilization of glassware and equipment

- 14.53 This cycle corresponds to the “glassware and equipment” cycle specified in BS 2646. It is designed to sterilise clean, empty glassware (without caps) and equipment such as tubing and filters. Loads must not contain any fluids.
- 14.54 Some microbiological filter membranes may be damaged by the rapid fluctuations in pressure used by an active air-removal system, and it may be necessary to provide a separate filter cycle.

Free steaming

- 14.55 This cycle is not specified in BS 2646. It is designed to melt solidified agar by exposing it to steam near atmospheric pressure. It is normally a variable cycle. If the workload is heavy, this will not be a cost-effective way of using a sterilizer and a Köch steamer may be more suitable.

Culture media preparators

- 14.56 Many of the problems which relate to sterilising culture media can be solved by the use of small sterilizers in which the media constituents are placed directly into the chamber, thus avoiding the use of glass containers and their attendant hazards. Since these small machines have a unique function, their design is specialised in comparison with other laboratory sterilizers and BS 2646 is not applicable.
- 14.57 A culture media preparator consists of two or three modules incorporated into a system designed to provide controlled preparation, sterilization, cooling and dispensing of culture media with a minimum of attention by the

operator. The system may also include a module which automatically stacks the completed culture plates.

- 14.58 The sterilizer module consists of a pressure vessel which contains the medium, surrounded by a jacket (which may itself be a pressure vessel) containing a heat transfer fluid (usually water) or separate heating elements and coils. Throughout the preparation and sterilising part of the process heat is transmitted from the jacket to the culture medium to attain a controlled temperature between 80°C and 130°C in order to dissolve the constituents and sterilise the resultant culture medium. After a predetermined time at the sterilization temperature the medium is rapidly cooled to a controlled dispensing temperature between 40°C and 60°C. Cooling is usually achieved by circulating cold water. Provision is also made for adding solutions to the sterilized cooled medium before possible reheating, cooling and final dispensing.
- 14.59 The sterilizer module of these systems should conform with the UK Health Departments' specifications set out in *Performance and safety specification for culture media sterilizers* (STB 3A/85/12) with the following modifications:
- both inner and outer vessels must have a pressure relief valve; these must be dedicated safety valves set to prevent the vessel being over-pressurised and not have any other function. They must be positioned so that in the event of the valves operating the discharge will not be expelled into the immediate working area;
 - port covers should be made of a material, such as stainless steel, which will not distort under normal operating conditions.

Discard boxes

- 14.60 When a sterilizer intended for use with make-safe cycles is purchased, suitable boxes will need to be specified for receiving discard material, transporting it from the laboratory bench to the sterilizer, and containing the load during the sterilization process. Enough boxes to load the chamber fully should be provided.
- 14.61 The sterilizer manufacturer will have used a certain type of discard box in determining the cycle time. If other types are used for routine production, the cycle time may differ considerably.
- 14.62 The design of the box can greatly affect the overall cycle time, varying between 45 minutes and two hours when the process incorporates an active air-removal system, and between two and six hours for processes based on passive displacement. Figure 3 illustrates a typical commercially available discard box.
- 14.63 The box should be designed to facilitate the removal of air from the load and the penetration of steam into the load.



- 14.64 The box material should be impervious, conduct heat well, be robust, resistant to puncturing, easily cleanable and able to withstand the sterilization process without damage. Stainless steel, aluminium and plastic are the most common materials:
- stainless steel, preferably coated with polytetrafluoroethylene (PTFE), is the material of choice. Its principal advantages are resistance to distortion at sterilization temperatures, good heat transfer and “non-stick” properties;
 - aluminium is lighter than other metals but is prone to metal fatigue and cracking, and so has a shorter life expectancy;
 - plastic boxes are cheaper than those made of metal but conduct heat poorly, increasing energy consumption and lengthening cycle times. Where inserts are used to segregate solid from liquid discard, a plastic box may distort and prevent the discard or insert from being withdrawn.
- 14.65 Where small discard is to be made safe, the box should contain a trivet to support the load before sterilization and allow any liquids to drain to the bottom of the box during the cycle. This will make it easier to separate solid and liquid residues for disposal.
- 14.66 Discard should be enclosed when the box is being moved. Loose-fitting lids are satisfactory for transport within a laboratory. Alternatively, the discard material may be placed in a discard bag (see paragraph 14.67) inside an open box, providing the neck of the bag is closed. Whenever discard material is transported outside the laboratory suite, a sealed and locked lid should be fitted. Where the lid can affect the efficacy of the sterilization process, it should be opened or removed before the cycle begins and sterilized along with the box.
- 14.67 Bags, usually plastic, are available with identification markings for discard material. The bags are often manufactured in a material which will melt at 134°C to assist air removal. Discard bags should always be contained in a discard box and opened wide before sterilization.

Figure 3: An example of a laboratory discard container

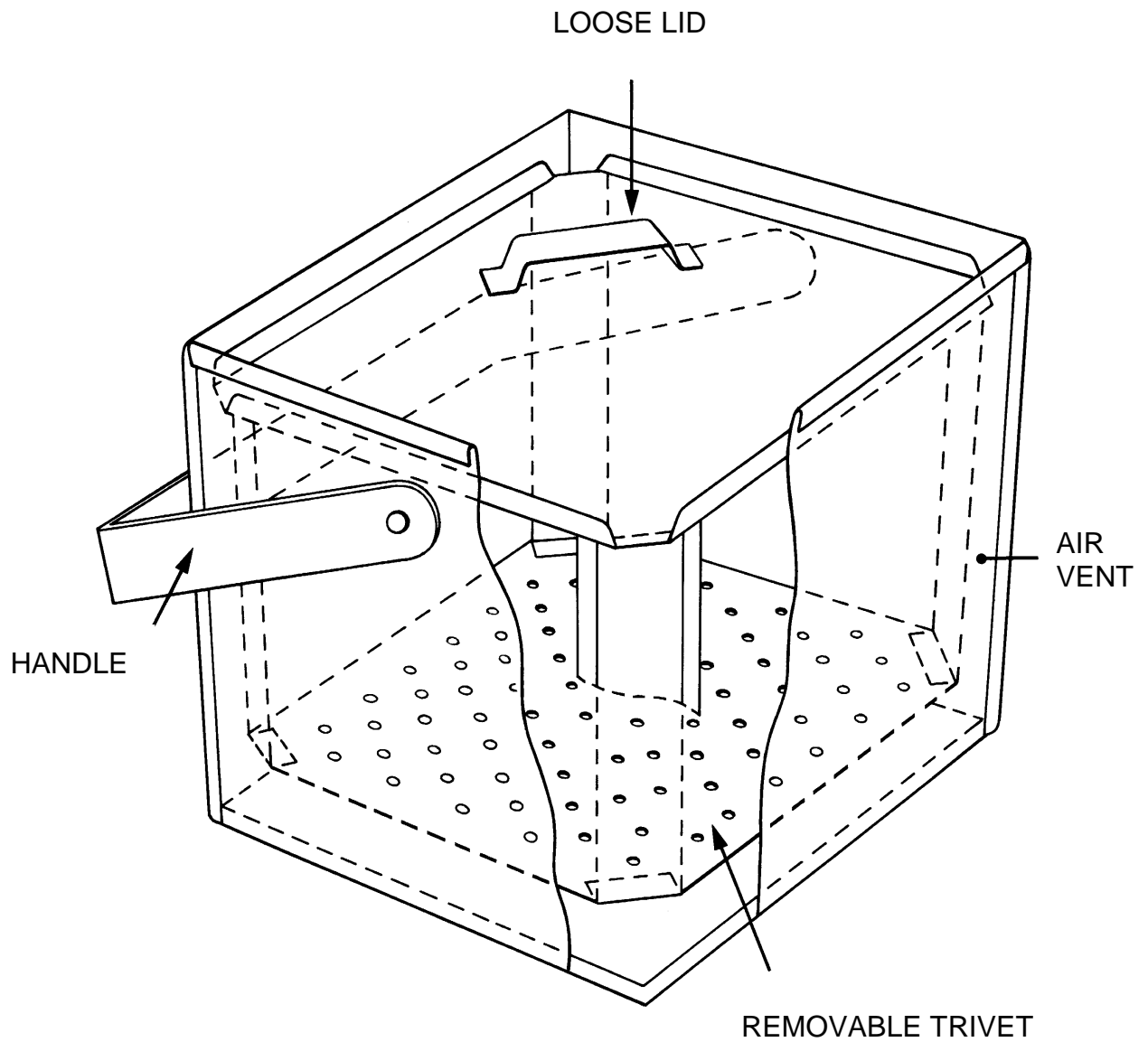

Typical size: 250 mm high
 310 mm x 310 mm base



Glossary

The following list of definitions has been adopted in SHTM 2010 and used in Part 2. Certain pressure terms have been modified to comply with the requirements of BS EN 764. Cross references to other terms are shown in bold type.

absolute pressure	pressure for which the zero value is associated with absolute vacuum.
aeration	a part of the sterilization process during which sterilant gas and/or its reaction products desorb from the load until predetermined levels are reached. See degassing and flushing .
air detector	a device used to determine that sufficient air or other non-condensable gases have been removed from the chamber .
allowable pressure	of a pressure vessel, a limit to the operating pressure specified for safety reasons. See design pressure .
automatic controller	a device that, in response to predetermined cycle variables , operates the sterilizer sequentially through the required stages of the operating cycle .
batch process record (BPR)	a permanent record of one or more cycle variables recorded during a complete operating cycle by instruments fitted permanently to the sterilizer .
biological indicator	a device, consisting of an inoculated carrier contained within a primary pack, designed to test the efficacy of an operating cycle .
Bowie-Dick test	a test, used mainly with porous load sterilizers, to show whether or not steam penetration into a standard test pack is even and rapid.
cartridge	in EO sterilizers , a portable, single-use, simple vessel containing sterilant gas under pressure from which the gas is delivered by puncturing the cartridge.
chamber	the part of the sterilizer in which the load is placed.
chamber exhaust ventilation (CEV)	a ventilation system designed to extract gas from the chamber of an EO sterilizer supplied from a cartridge .



chamber furniture	shelves, pallets, loading trolleys and other fixed or movable parts that support the load within the chamber .
chamber temperature	the lowest temperature prevailing in the chamber .
chemical indicator	a device designed to show, usually by change of colour, whether specified values of one or more cycle variables have been attained.
clinical sterilizer	a sterilizer designed to process medical devices or medicinal products to be used in the clinical care of patients.
commissioning	the process of obtaining and documenting evidence that equipment has been provided and installed in accordance with the equipment specifications and that it functions within predetermined limits when operated in accordance with the operational instructions.
conditioning	in EO sterilizers , the treatment of a load within the operating cycle , but prior to sterilization , to attain a predetermined temperature and humidity throughout the load.
contained fluid discard	discard material held in sealed glass containers or sealed plastic containers of volume greater than 50 ml (see small plastic discard).
cooling stage	the period of the operating cycle , after the holding time has been completed, during which the load remains in the chamber while the load cools to a safe temperature.
culture media preparator	a specialised laboratory sterilizer designed for the sterilization and dispensing of culture media.
cycle complete	recognition by the automatic controller that the preset values for the cycle variables , necessary for a successful operating cycle , have been attained and that the sterilized load is ready for removal from the chamber .
cycle variables	the physical properties, for example time, temperature, pressure, humidity and gas concentration, that influence the efficacy of the operating cycle .
dedicated steam supply	a supply of steam produced by a generator for the exclusive use of a sterilizer or group of sterilizers.



degassing	<ol style="list-style-type: none">1. in LTSF and EO sterilizers, an aeration procedure in which sterilant gas and its reaction products are desorbed from the load by defined treatment outside the sterilizer after completion of the operating cycle.2. a pre-heating treatment of boiler feed-water to reduce the amount of non-condensable gases in the steam supply.
design pressure	of a pressure vessel, the pressure chosen for the design calculations. See operating pressure , allowable pressure .
discard	laboratory material which is, or may be, infected by micro-organisms and is to be made safe before disposal.
discard bag	a bag, usually of plastic, designed to receive solid discard material before being placed in a discard box for processing by a make-safe cycle.
discard box	a box designed to contain discard material for processing by a make-safe cycle.
disinfection	a process used to reduce the number of viable micro-organisms in a load but which may not necessarily inactivate some viruses and bacterial spores.
disinfector	an apparatus designed to achieve disinfection .
double-ended sterilizer	a sterilizer in which there is a door at each end of the chamber .
dry-heat sterilizer	a clinical sterilizer designed to sterilise loads by exposure to hot dry air near atmospheric pressure.
dryness value	a dimensionless quantity, approximating to the dryness fraction, derived to determine whether steam is of the correct dryness for sterilization purposes. A dryness value of 1.0 represents dry saturated steam .
EO sterilizer	a clinical sterilizer designed to sterilise loads by exposure to ethylene oxide gas or EO gas mixtures.
equilibration time	the period which elapses between the attainment of the sterilization temperature in the chamber and the attainment of the sterilization temperature in all parts of the load .



ethylene oxide (EO)	sterilant gas used to sterilise items that would be damaged by exposure to heat or moisture. Chemical formula $\text{CH}_2\text{CH}_2\text{O}$.
F_0	a quantity, measured in minutes, used to determine the efficacy of an operating cycle and equivalent to a continuous period at a temperature of 121°C.
fail-safe	an attribute of sterilizer design whereby failure of any component or its associated services does not create a safety hazard.
fault	the recognition by the automatic controller that the preset cycle variables for the operating cycle have not been attained and that sterilization or disinfection has been jeopardised.
flash sterilizer	a device designed to achieve sterilization by exposing the load to a very high temperature steam for a few seconds.
fluid sterilizer	a clinical sterilizer designed to sterilise fluids in sealed containers by exposure to high-temperature steam under pressure.
flushing	in LTSF and EO sterilizers , an aeration procedure by which remaining sterilant gas is removed from the load within the chamber by the passage of air or other inert gas.
formaldehyde	sterilant gas used in combination with low-temperature steam to sterilise items that would be damaged by exposure to high-temperature steam . Chemical formula HCHO . Also known as methanal.
formalin	formaldehyde Solution BP. A 38% aqueous solution of formaldehyde stabilised with 10% w/v ethanol, commonly used as the primary material for generating formaldehyde gas.
free steaming	a process, used in laboratory sterilizers , in which the load is exposed to steam near atmospheric pressure.
free-standing	of a sterilizer , installed in a room which is not separated into a plantroom and a loading area .
full load	a specified load , used in thermometric tests, to represent the maximum size and mass of load which the sterilizer is designed to process.



gas exposure time	in EO sterilizers , the time for which the chamber is maintained at the specified temperature, gas concentration, pressure and humidity.
gauge pressure	pressure equal to the difference between the absolute pressure and local atmospheric pressure.
high-temperature steam	steam at a temperature above the boiling point of water at local atmospheric pressure.
holding time	the period during which the temperature in all parts of the chamber, load and any coolant fluid is held within the sterilization temperature band . It follows immediately after the equilibration time .
hot-air sterilizer	see dry-heat sterilizer .
indicated	an indicated value is that shown by a dial or other visual display fitted permanently to the sterilizer (see recorded and measured).
installation checks	a series of checks performed by the contractor to establish that the sterilizer has been provided and installed correctly, is safe to operate, does not interfere with nearby equipment and that all connected services are satisfactory and do not restrict the attainment of conditions for sterilization .
installation tests	a series of tests performed by the contractor after the installation checks to demonstrate that the sterilizer is working satisfactorily.
integral steam supply	a supply of steam produced in a sterilizer chamber or in a generator directly connected to it. The pressure in the sterilizer chamber is equal to that in the generator.
Köch steamer	a laboratory apparatus designed to expose a load to steam near atmospheric pressure and commonly used for melting solidified agar.
laboratory sterilizer	a sterilizer designed to sterilise, disinfect or make-safe laboratory materials and equipment.
load	collectively, all the goods, equipment and materials that are put into a sterilizer or disinfecter at any one time for the purpose of processing it by an operating cycle .
load item	one of several discrete containers, packs or other units that together constitute a load .



load-temperature probe	a movable temperature sensor fitted within the sterilizer chamber and designed to record the temperature inside selected load items .
loading area	the room or area in front of the sterilizer in which the operator works and from which the sterilizer is loaded and unloaded. It is commonly separated by a fascia panel from the plantroom .
loading condition	a specified combination of the nature and number of load items , the items of chamber furniture , and their distribution within the chamber .
loading factor	the average fraction of the usable chamber space occupied by a load during normal operation.
local exhaust ventilation (LEV)	a ventilation system designed to extract small amounts EO or formaldehyde vapour released during normal operation of a sterilizer and its ancillary equipment.
low-temperature steam (LTS)	steam at a temperature below the boiling point of water at local atmospheric pressure.
LTS disinfectant	a clinical disinfectant designed to disinfect loads by exposure to low-temperature steam at sub-atmospheric pressure.
LTSF sterilizer	a clinical sterilizer designed to sterilise loads by exposure to low-temperature steam and formaldehyde gas at sub-atmospheric pressure.
mains steam supply	the supply of steam produced for distribution to a range of steam-consuming equipment by an independent common boiler.
make-safe	a process, used in laboratory sterilizers , to reduce the microbial content of contaminated material so that it can be handled and disposed of without causing an infection hazard or environmental contamination.
master process record (MPR)	a batch process record obtained from a thermometric commissioning or performance qualification test and annotated to show the permitted tolerances for cycle variables during subsequent testing and routine production.



measured	a measured value is that shown on a test instrument, such as a thermometric recorder or a test pressure gauge, attached to the sterilizer for test purposes (see indicated and recorded).
medical device	any instrument, apparatus, appliance, material or other article, whether used alone or in combination, including the software necessary for its proper application, intended by the manufacturer to be used on human beings for the purpose of: diagnosis, prevention, monitoring, treatment or alleviation of disease; diagnosis, monitoring, treatment, alleviation or compensation for an injury or handicap; investigation, replacement or modification of the anatomy or of a physiological process; control of conception; and which does not achieve its principal intended action in or on the human body by pharmacological, immunological or metabolic means, but which may be assisted in its function by such means. (Source: EU Council Directive 93/42/EEC.)
medicinal product	any substance or combination of substances presented for treating or preventing disease in human beings or animals. Any substance or combination of substances which may be administered to human beings or animals with a view to making a medical diagnosis or to restoring, correcting or modifying physiological functions in human beings or in animals is likewise considered a medicinal product. (Source: EU Council Directive 65/65/EEC.)
module	a standard unit of chamber size being a rectangular box measuring 300 x 300 x 600 mm of volume 54 litres.
non-condensable gases (NCGs)	gases which cannot be liquefied by compression under the range of conditions of temperature and pressure used during the operating cycle .
noted	a noted value is that written down by the operator, usually as the result of observing an indicated, recorded or measured value.
operating cycle	the set of stages of the sterilization or disinfection process carried out in sequence and regulated by the automatic controller . It is synonymous with the terms "sterilization cycle" for sterilizers and "disinfection cycle" for disinfectors .
operating pressure	the pressure in the chamber during the plateau period of an operating cycle . See allowable pressure, design pressure .



override	a system by which the progress of the operating cycle can be interrupted or modified as necessary.
paraformaldehyde	a mixture of polymethylene glycols formed by the reaction of formaldehyde with water.
performance class	an integer, from 1 to 20, related to the total cycle time for a sterilizer with a full load .
performance qualification (PQ)	the process of obtaining and documenting evidence that the equipment, as commissioned, will produce acceptable product when operated in accordance with the process specification.
performance requalification (PRQ)	the process of confirming that the evidence obtained during performance qualification remains valid.
periodic tests	a series of tests carried out at daily, weekly, quarterly and yearly intervals.
personal protective equipment (PPE)	equipment, including clothing, which is intended to be worn or held by a person at work, which protects against one or more risks to his or her health and safety.
plant history file	a file containing validation , maintenance and other engineering records for each sterilizer .
plantroom	the room or area to the rear of the sterilizer in which services are connected and which provides access for maintenance. It is commonly separated by a fascia panel from the loading area .
plateau period	the equilibration time plus the holding time .
porous-load sterilizer	a clinical sterilizer designed to process, by exposure to high-temperature steam under pressure, porous items such as towels, gowns and dressings, and also medical devices that are wrapped in porous materials such as paper or fabrics.
preconditioning	treatment of a load to attain predetermined conditions, such as temperature and humidity, before the start of an operating cycle .
pressure ballasting	a technique used in fluid sterilizers by which the pressure in the chamber is maintained at or near to the pressure inside the load containers during all or part of the operating cycle .



pressure vessel	a collective term describing the sterilizer chamber , jacket (if fitted), door(s) and components that are in permanent open connection with the chamber.
priming	of a steam generator, the delivery of steam containing water in suspension due to violent boiling or frothing.
process indicator	a chemical indicator used to distinguish between processed and unprocessed load items.
pyrogen	a bacterial toxin that causes a rise in body temperature and which is not destroyed by steam sterilization .
recommissioning	a procedure to confirm that operational data established during commissioning remain valid.
recorded	a recorded value is that shown on the output of a recording instrument fitted permanently to the sterilizer (see indicated and measured).
revalidation	a procedure to confirm an established validation , consisting of recommissioning followed by performance requalification .
safety hazard	a potentially detrimental effect on persons or the surroundings arising directly from either the sterilizer or its load .
saturated steam	steam whose temperature, at any given pressure, corresponds to that of the vaporisation curve of water.
small load	a specified load , used in thermometric tests, to represent the minimum size and mass of load which the sterilizer is designed to process.
small plastic discard	discard material comprising or held in plastic containers not exceeding 50 ml in volume.
sterilant	an agent used to effect sterilization , such as steam, hot air or a sterilising gas.
sterile	condition of a load item that is free from viable micro-organisms. See BS EN 556 for the requirements for a medical device to be labelled "sterile".
sterilization	a process undertaken to render a load sterile .



sterilization conditions	the ranges of the cycle variables which may prevail throughout the chamber and load during the holding time .
sterilization process	the complete set of procedures required for sterilization of a load , including the operating cycle and any treatment of the load before or after the operating cycle.
sterilization temperature	minimum acceptable temperature of the sterilization temperature band .
sterilization temperature band	the range of temperatures which may prevail throughout the load during the holding time . These temperatures are expressed as a minimum acceptable (the sterilization temperature) and a maximum allowable and are stated to the nearest degree Celsius.
sterilizer	an apparatus designed to achieve sterilization .
sterilizer process log	a log, kept by the User, which contains records for each production cycle.
superheated steam	steam whose temperature, at any given pressure, is higher than that indicated by the vaporisation curve of water.
thermal door lock	an interlock fitted to certain sterilizers to prevent the door from being opened until the temperature in the chamber and load falls below a preset value.
transportable	requiring no permanent connections or installation and capable of being moved manually without mechanical assistance. Synonymous with "bench-top".
type tests	a series of tests conducted by the manufacturer to establish the working data for a sterilizer type.
usable chamber space	the space inside the chamber which is not restricted by chamber furniture and which is consequently available to accept the load .
utilisation factor	the fraction of the open hours for which a sterilizer is available to process loads.
validation	a documented procedure for obtaining, recording and interpreting data required to show that a sterilization process will consistently comply with predetermined specifications.



works tests

a series of tests to establish the efficacy of each **sterilizer** at the manufacturer's works.

Abbreviations

BPR	batch process record
BS	British Standard
°C	degree Celsius
CEN	European Committee for Standardisation (Comité Européen de Normalisation)
CEV	chamber exhaust ventilation
COSHH	Control of Substances Hazardous to Health (Regulations)
dBA	decibel, A-weighted
EMC	electromagnetic compatibility
EN	European Standard (Europäische Norm)
EO	ethylene oxide
EU	European Union (formerly European Community)
GGMP	EU, <i>Guide to good manufacturing practice for medicinal products</i>
h	hour
HBN	Health Building Note
HDN	Hospital Design Note
HSC	Health and Safety Commission
HSE	Health and Safety Executive
HTM	Health Technical Memorandum (UK)
ISO	International Organisation for Standardisation
kW	kilowatt
l	litre
LEV	local exhaust ventilation
LTMEL	long-term maximum exposure limit
LTS	low-temperature steam
LTSF	low-temperature steam and formaldehyde
µm	micrometre (micron, 10 ⁻⁶ m)
m	metre
mbar	millibar (10 ⁻³ bar)
MCA	Medicines Control Agency
MDA	Medical Devices Agency
mg	milligram (10 ⁻³ g)
min	minute
ml	millilitre (10 ⁻³ l)
mm	millimetre (10 ⁻³ m)
mmol	millimole (10 ⁻³ mole)
MPR	master process record
NCG	non-condensable gas
PES	programmable electronic system
ppm	parts per million
PQ	performance qualification
PRQ	performance requalification
RH	relative humidity
s	second



SHPN Scottish Hospital Planning Note
SHTM Scottish Health Technical Memorandum
SSD sterile services department
STMEL short-term maximum exposure limit
UK United Kingdom

References

NOTE:

Where there is a requirement to address a listed reference, care should be taken to ensure that all amendments following the date of issue are included.

Publication ID	Title	Publisher	Date	Notes
Acts and Regulations				
	Building (Scotland) Act	HMSO	1959	
	Clean Air Act	HMSO	1993	
	Consumer Protection Act	HMSO	1987	
	Electricity Act	HMSO	1989	
	Health and Safety at Work etc Act	HMSO	1974	
	Health and Medicines Act	HMSO	1988	
	Registered Establishments (Scotland) Act	HMSO	1998	
	Water (Scotland) Act	HMSO	1980	
SI 3146	Active Implantable Medical Devices Regulations	HMSO	1992	
SI 1995	Active Implantable Medical Devices (Amendment and Transitional Provisions) Regulations 1995	HMSO	1995	
SI 2179 & 187	Building Standards (Scotland) Regulations (as amended)	HMSO	1990	
SI 2092	Carriage of Dangerous Goods (Classification, Packaging & Labelling) and Use of Transportable Pressure Receptacles Regulations	HMSO	1996	
	Building Standards (Scotland) Regulations: Technical Standards Guidance	HMSO	1998	
SI 1460	Chemicals (Hazard Information and Packaging for Supply) Regulations (CHIP2)	HMSO	1997	
SI 3140	Construction (Design and Management) Regulations	HMSO	1994	
SI 437	Control of Substances Hazardous to Health Regulations (COSHH)	HMSO	1999	
SI 635	Electricity at Work Regulations	HMSO	1989	
SI 1057	Electricity Supply Regulations (as amended)	HMSO	1988	



Publication ID	Title	Publisher	Date	Notes
SI 2372	Electromagnetic Compatibility Regulations (as amended)	HMSO	1992	
SI 2451	Gas Safety (Installation and Use) Regulations	HMSO	1998	
SI 917	Health & Safety (First Aid) Regulations	HMSO	1981	
SI 682	Health & Safety (Information for Employees) Regulations	HMSO	1989	
SI 1380	Health and Safety (Training for Employment) Regulations	HMSO	1990	
SI 341	Health and Safety (Safety Signs and Signals) Regulations	HMSO	1996	
SI 2792	Health and Safety (Display Screen Equipment) Regulations	HMSO	1992	
SI 1315	In Vitro Diagnostic Medical Devices Regulations 2000	HMSO	2000	
SI 3232	Ionising Radiations Regulations 1999	HMSO	1999	
SI 2307	Lifting Operations and Lifting Equipment Regulations (LOLER)	HMSO	1998	
SI 2051	Management of Health and Safety at Work Regulations	HMSO	1999	
SI 2793	Manual Handling Operations Regulations	HMSO	1992	
SI 3017	Medical Devices Regulations	HMSO	1994	
SI 1790	Noise at Work Regulations	HMSO	1989	
SI 2966	Personal Protective Equipment at Work (PPE) Regulations	HMSO	1992	
SI 2306	Provision and Use of Work Equipment Regulations (PUWER)	HMSO	1998	
SI 3139	Personal Protective Equipment (EC Directive) Regulations	HMSO	1992	
SI 128	Pressure Systems Safety Regulations (PSSR)	HMSO	2000	
SI 3163	Reporting of Injuries, Diseases and Dangerous Occurrences Regulations (RIDDOR)	HMSO	1995	
SI 119	Water Supply (Water Quality) (Scotland) Regulations	HMSO	1990	
SI 3004	Workplace (Health, Safety and Welfare) Regulation	HMSO	1992	



Publication ID	Title	Publisher	Date	Notes
British Standards				
BS 593	Specification for laboratory thermometers		1989	
BS 1781	Specification for linen and linen union textiles		1981	
BS 2646	Autoclaves for sterilization in laboratories Part 1: Specification for design, construction, safety and performance Part 2: Guide to planning and installation Part 3: Guide to safe use and operation Part 4: Guide to maintenance Part 5: Methods of testing for function and performance	BSI Standards	1993 1990 1993 1991 1993	
BS 2648	Performance requirements for electrically heated laboratory drying ovens (PD2517,6/56)	BSI Standards	1955	
BS 2775	Specification for rubber stoppers and tubing for general laboratory use		1987	
BS 3693	Recommendations for design of scales and indexes on analogue indicating instruments		1992	
BS 3928	Method for sodium flame test for air filters (other than for air supply to I.C. engines and compressors)	BSI Standards	1969	



Publication ID	Title	Publisher	Date	Notes
BS 3970	<p>Sterilizing and disinfecting equipment for medical products</p> <p>Part 1: Specification for general requirements</p> <p>Part 2: Specification for steam sterilizers for aqueous fluids in sealed rigid containers</p> <p>Part 3: Specification for steam sterilizers for wrapped goods and porous loads</p> <p>Part 4: Specification for transportable steam sterilizers for unwrapped instruments and utensils</p> <p>Part 5: Specification for low temperature steam disinfectors</p> <p>Part 6: Specification for sterilizers using low temperature steam with formaldehyde</p>	BSI Standards	1990 1991 1990 1990 1993	
BS 4196-0	Sound power level of noise sources. Guide for the use of basic standards and for the preparation of noise test codes	BSI Standards	1981	
BS 4275	Guide to implementing an effective respiratory protective device programme	BSI Standards	1997	
BS 5164	Specification for indirect acting electrical indicating and recording instruments and their accessories		1975	
BS 5295	<p>Environmental cleanliness in enclosed spaces</p> <p>Part 1: Specification for clean rooms and clean air devices</p>		1989	
BS 5304	British standard code of practice for safety of machinery	BSI Standards	1988	
BS 5815	<p>Sheets, sheeting, pillowslips, towels, napkins and continental quilts secondary covers</p> <p>Parts 1: Specification for sheeting etc</p> <p>Part 2: specification for towels etc.</p> <p>Part 3: Specification for counterpanes etc.</p>	BSI Standards	1989 1988 1991	



Publication ID	Title	Publisher	Date	Notes
BS 6000	Guide for the selection of an acceptance sampling system, scheme or plan for inspection of discrete items in lots	BSI Standards	1996	
BS 6001	Sampling procedures for inspection by attributes	BSI Standards	1991	
BS 6068	Water quality Sect.1.2 Glossary Sect 6.5 Guidance on sampling of drinking water and water used for food processing Sect. 6.7 Guidance on sampling of water and steam in boiler plants.	BSI Standards	1997 1991 1994	
BS 6257	Specification for paper bags for steam sterilization for medical use		1989	
BS 6447	Specification for absolute and gauge pressure transmitters with electrical outputs		1984	
BS 7671	Requirements for electrical installations. IEE wiring regulations	BSI Standards	1992	16 th edition
BS 7720	Specification for non-biological sterilization indicators equivalent to the Bowie and Dick Test		1995	
BS EN 134	Respiratory protective devices. Nomenclature of components. Names of components in three CEN languages and diagrams for respiratory protective equipment	BSI Standards	1998	
BS EN 285	Sterilization, steam sterilizers, large sterilizers	BSI Standards	1997	
BS EN 550	Sterilization of medical devices. Validation and routine control of sterilization by ethylene oxide	BSI Standards	1994	
BS EN 552	Sterilization of medical devices. Validation and routine control of sterilization by irradiation	BSI Standards	1994	
BS EN 554	Sterilization of medical devices. Validation and routine control of sterilization by moist heat	BSI Standards	1994	



Publication ID	Title	Publisher	Date	Notes
BS EN 556	Sterilization of medical devices. Requirements for terminally sterilized medical devices to be labelled 'STERILE'	BSI Standards	1995	
BS EN 724	Guidance on the application of EN 29001 and EN 46001 and of EN 29002 and EN 46002 for non-active medical devices	BSI Standards	1995	
BS EN 764	Pressure equipment. Terminology and symbols: pressure, temperature, volume	BSI Standards	1995	
BS EN 837-1	Bourdon tube pressure gauges: dimensions, metrology, requirements and testing	BSI Standards	1998	
BS EN 866	Biological systems for testing sterilizers and sterilization processes Part 1: General requirements Part 2: Particular systems for use in ethylene oxide sterilizers Part 3: Particular systems for use in moist heat sterilizers	BSI Standards	1997 1998 1997	
BS EN 867	Non-biological systems for use in sterilizers Part 1: General requirements Part 2: Process indicators Part 3: Specification for Class B indicators for use in the Bowie and Dick test	BSI Standards	1997	
BS EN 868	Packaging materials and systems for medical devices which are to be sterilized. General requirements	BSI Standards	1997	
BS EN 980	Graphical symbols for the use in the labelling of medical devices	BSI Standards	1997	
BS EN 1174	Sterilization of medical devices. Estimation of population of micro-organisms on product	BSI Standards	1996	
BS EN 1422	Sterilizers for medical purposes – ethylene oxide sterilizers – specification	BSI Standards	1998	
BS EN 22872	Complete, filled transport packages. Method for determination of resistance to compression	BSI Standards	1993	



Publication ID	Title	Publisher	Date	Notes
BS EN 25667-1	Water quality. Guidance on design of sampling programmes	BSI Standards	1994	
BS EN 25667-2	Water sampling . Guidance on sampling techniques	BSI Standards	1993	
BS EN 30993	Biological evaluation of medical devices Part 3: Tests for genotoxicity, carcinotoxicity, and reproductive toxicity Part 4: Selection of tests for interaction with blood Part 5: Tests for cytotoxicity, in vitro methods Part 6: Tests for local effects after implantation	BSI Standards	1994 1994 1994 1995	
BS EN ISO 3746	Acoustics. Determination of sound power levels of noise sources using sound pressure. Survey method using an enveloping measurement surface over a reflecting plane	BSI Standards	1996	
BS EN 45003	Calibration and testing laboratory accreditation systems, general requirements for operation and recognition	BSI Standards	1995	
BS EN 45011	General requirements for bodies operating product certification systems	BSI Standards	1998	
BS EN 45012	General requirements for bodies operating assessment and certification/registration of quality system	BSI Standards	1998	
BS EN 45014	General criteria for supplier's declaration of conformity	BSI Standards	1993	
BS EN 45020	Standardization and related activities	BSI Standards	1998	
BS EN 46001	Specification for the application of EN ISO9001 to the manufacture of medical devices	BSI Standards	1997	
BS EN 46002	Specification for the application of EN ISO9002 to the manufacture of medical devices	BSI Standards	1994	



Publication ID	Title	Publisher	Date	Notes
BS EN 50081	Electromagnetic compatibility. Generic emission standard Part 1: Residential, commercial and light industry Part 2: Industrial environment	BSI Standards	1992 1994	
BS EN 50082	Electromagnetic compatibility. Generic immunity standard Part 1: Residential, commercial and light industry Part 2: Industrial environment	BSI Standards	1998 1995	
BS EN 60079-14	Electrical apparatus for explosive gas atmospheres. Electrical installations in hazardous areas (other than mines)	BSI Standards	1997	
BS EN 60581-2	Thermocouples. Manufacturing tolerances	BSI Standards	1996	
BS EN 60584-1	Thermocouples reference table	BSI Standards	1996	
BS EN 60651	Specification for sound level meters	BSI Standards	1994	
BS EN 60751	Industrial platinum resistance thermometer sensors		1996	
BS EN 60804	Specification for integrating averaging sound level meters		1994	
BS EN 61010	Safety requirements for electrical equipment for measurement, control and laboratory use -1: General requirements -2-041: Particular requirements for autoclaves and sterilizers using steam for the treatment of medical materials and for laboratory processes -2-042: Particular requirements for autoclaves and sterilizers using toxic gas for the treatment of medical materials and for laboratory processes -2-043: Particular requirements for autoclaves and sterilizers using either hot air or hot inert gas for the treatment of medical materials and for laboratory processes		1993 1997 1997 1998	



Publication ID	Title	Publisher	Date	Notes
BS EN ISO 9001	Quality systems. Model for quality assurance in design, development, production, installation and servicing	BSI Standards	1994	
BS EN ISO 9002	Quality systems. Model for quality assurance in production, installation and servicing	BSI Standards	1994	
European Union Directives				
65/65/EEC	Approximation of provisions laid down by law, regulation or administrative action relating to proprietary medicinal products.	Official Journal of the European Communities (OJEC), no 22, 9/2/65, p 369		
75/107/EEC	Approximation of the laws of member states relating to bottles used as measuring containers.	Official Journal of the European Communities (OJEC), L42, 15/2/75		
90/385/EEC	Approximation of the laws of the Member States relating to active implantable medical devices.	Official Journal of the European Communities (OJEC), L189 20/7/90, p 17		
91/356/EEC	Laying down the principles and guidelines of good manufacturing practice for medicinal products for human use.	Official Journal of the European Communities (OJEC). L193 17/7/91, p 30		
80/778/EEC	Quality of water intended for human consumption	Official Journal of the European Communities, 1980		
93/42/EEC	Medical Devices Directive	Official Journal of the European Communities (OJEC), L169 12/7/93, p 1		
98/79/EC	In Vitro Diagnostic Medical Devices Directive	Official Journal of the European Communities, (OJEC), L331 7/12/98		
Scottish Health Technical Guidance				
SHTM 2007	Electrical services supply and distribution	P&EEx	2001	CD-ROM
SHTM 2011	Emergency electrical services	P&EEx	2001	CD-ROM
SHTM 2014	Abatement of electrical interference	P&EEx	2001	CD-ROM



Publication ID	Title	Publisher	Date	Notes
SHTM 2020	Electrical safety code for low voltage systems (Escode – LV)	P&EFEx	2001	CD-ROM
SHTM 2022	Medical gas pipeline systems	P&EFEx	2001	CD-ROM
SHTM 2023	Access and accommodation for engineering services	P&EFEx	2001	CD-ROM
SHTM 2025	Ventilation in healthcare premises	P&EFEx	2001	CD-ROM
SHTM 2030	Washer-disinfectors	P&EFEx	2001	CD-ROM
SHTM 2027	Hot and cold water supply, storage and mains services	P&EFEx	2001	CD-ROM
SHTM 2030	Washer-disinfectors	P&EFEx	2001	CD-ROM
SHTM 2031	Clean steam for sterilizers	P&EFEx	2001	CD-ROM
SHTM 2040	Control of legionellae in healthcare premises – a code of practice	P&EFEx	2001	CD-ROM
SHTM 2045	Acoustics	P&EFEx	2001	CD-ROM
SHPN 1	Health service building in Scotland	HMSO	1991	
SHPN 2	Hospital briefing and operational policy	HMSO	1993	
SHPN 13	Sterile services department	HMSO	1994	
SHPN 15	Accommodation for pathology services	HMSO	1994	
SHTN 1	Post commissioning documentation for health buildings in Scotland	HMSO	1993	
SHTN 2	Domestic hot and cold water systems for Scottish Health Care Premises	EEF	1999	CD-ROM
SHTN 4	General Purposes Estates and Facilities Model Safety Permit-to-Work system	EEF	1998	CD-ROM
SHGN	'Safe' hot water and surface temperatures	EEF	1999	CD-ROM
	NHS in Scotland – PROCODE	P&EFEx	2001	Version 1.1
NHS in Scotland Firecode				
SHTM 81	Fire precautions in new hospitals	P&EFEx	1999	CD-ROM
SHTM 82	Alarm and detection systems	P&EFEx	1999	CD-ROM
SHTM 83	Fire safety in healthcare premises: general fire precautions	P&EFEx	1999	CD-ROM
SHTM 84	Fire safety in NHS residential care properties	P&EFEx	1999	CD-ROM
SHTM 85	Fire precautions in existing hospitals	P&EFEx	1999	CD-ROM
SHTM 86	Fire risk assessment in hospitals	P&EFEx	1999	CD-ROM
SHTM 87	Textiles and furniture	P&EFEx	1999	CD-ROM
SFPN 3	Escape bed lifts	P&EFEx	1999	CD-ROM



Publication ID	Title	Publisher	Date	Notes
SFPN 4	Hospital main kitchens	P&EFEx	1999	CD-ROM
SFPN 5	Commercial enterprises on hospital premises	P&EFEx	1999	CD-ROM
SFPN 6	Arson prevention and control in NHS healthcare premises	P&EFEx	1999	CD-ROM
SFPN 7	Fire precautions in patient hotels	P&EFEx	1999	CD-ROM
SFPN 10	Laboratories on hospital premises	P&EFEx	1999	CD-ROM
UK Health Technical Guidance				
HBN 29	Accommodation for pharmaceutical services	HMSO	1988	As required
HTM 67	Building components: laboratory fitting out system	HMSO	1993	
CONCODE	Contracts and commissions for the NHS estate – contract procedures	HMSO	1994	
MES	Model Engineering Specifications	NHS Estates	1997	
MES C14	Sterilizers	NHS Estates	1993	
HBN 13	Supplement 1 – Ethylene oxide sterilization section	HMSO	1994	
MES C02	Thermal insulation	NHS Estates	1993	
Health and Safety Guidance				
EH 40	HSE Occupational Exposure limits	HSE	Annual	
HN(76)126	Hospital design note 4 (noise control): amendments to appendices II, IV and VII	DHSS	1976	
STB3A/85/12	Performance and safety specification for media sterilizers. Media devices directorate	DHSS	1985	
	Emmerson, A. M. <i>Sterilization, disinfection and cleaning of medical equipment: guidance on decontamination from the Microbiology Committee to the Department of Health Medical Devices Directorate.</i> Medical devices directorate	Department of Health	1993	
	<i>Biological tests for graded milk. Memo 139/Foods.</i>	Ministry of Health	1937	
	<i>Scottish Infection Manual Guidance on the core standards for the control of infection in hospitals, healthcare premises and at the community interface</i>	The Scottish Office	1998	



Publication ID	Title	Publisher	Date	Notes
L 5	<i>Programmable electronic systems in safety related applications: General technical guidelines</i>	HSE	1987	
	<i>Programmable electronic systems in safety related applications: an introductory guide</i>	HSE	1987	
	General COSHH ACOP (Control of substances hazardous to health) Carcinogens ACOP (Control of carcinogenic substances) and Biological agents ACOP (Control of biological agents) Control of Substances Hazardous to Health Regulations 1999 Approved Code of Practice	HSE	1999	
L 22	Safe use of work equipment: Approved code of practice and guidance	HSE	1998	
L 23	Manual handling operations: guidance on regulations	HSE	1998	
L 24	Workplace health, safety and welfare: Approved code of practice and guidance	HSE	1992	
L25	Personal protective equipment at work at work: guidance on regulations		1992	
L113	Safe use of lifting equipment: Approved code of practice and guidance	HSE	1998	
L122	Safety of pressure systems: Pressure Systems Safety Regulations 2000. Approved Code of Practice	HSE Books	2000	
PM73	Safety at Autoclaves	HSE Books	1998	
	Precautions for work with human and animal. Transmissible Spongiform Enccephalopathies	HSE (ACDP)		
HS(R)23	Categorisation of pathogens according to hazard and categories of containment	HSE (ACDP)	1995	4 th Edition
	Safe working and the prevention of infection in clinical laboratories	HSC (HSAC)		
	A guide to the 'Reporting of Injuries, Diseases and Dangerous Occurrences Regulations 1995	HSE	1995	



Publication ID	Title	Publisher	Date	Notes
Miscellaneous References				
GGMP Volume IV	Guide to good manufacturing practice for medicinal products – The rules governing medicinal products in the European Community			
	Atomic absorption spectrophotometry 1979 version	HMSO	1979	(out of print)
	Cadmium in potable waters by atomic absorption spectrophotometry 1976	HMSO	1976	(out of print)
	Colour and turbidity of waters 1981	HMSO	1981	(out of print)
	Determination of anions and cations, transition metals, and other complex ions and organic acids and bases in water by chromatography 1990	HMSO	1990	
	Lead in potable waters by atomic absorption spectrophotometry 1976	HMSO	1976	(out of print)
	Lead and cadmium in fresh waters by atomic absorption spectrophotometry (second edition) a general introduction to electrothermal atomization atomic absorption spectrophotometry 1986	HMSO	1986	(out of print)
	Measurements of electrical conductivity and the laboratory determination of the pH value of natural, treated and waste waters.	HMSO		(out of print)
	Mercury in waters, effluents, soils and sediments etc, additional methods	HMSO	1985	(out of print)
	Phosphorus and silicon in waters, effluents and sludges 1992	HMSO	1993	
Model Water Byelaws: Dept. of the Environment	HMSO	1986		
LG 2	Lighting guide: hospitals and healthcare buildings	Chartered Institution of Building Services Engineers	1989	
	Sterilization and disinfection of heat-labile equipment	Central Sterilizing Club	1986	



Appendix 1: Useful addresses

Medicines Control Agency,
Market Towers,
1 Nine Elms Lane,
London SW8 5NQ.
Tel. 0171-273 3000.

Medical Devices Agency,
14 Russell Square,
London WC1 B 5EP.
Tel. 0171-972 2000.

Scottish Executive Health Department
St Andrew's House,
Edinburgh EH1 3DG.
Tel. 0131-556 8400.

NHSScotland, Property and Environment Forum Executive,
4th Floor,
St Andrew House,
141 West Nile Street,
Glasgow, G1 2RN.
Tel. 0141 404 3737

Public Health Laboratory Service,
Central Public Health Laboratory,
61 Colindale Avenue,
London NW9 5HT.
Tel. 0181-200 4400.

Health and safety

Health and Safety Executive,
375 West George Street,
Glasgow, G2 4LW.
Tel. 0141 275 3000

Belford House
59 Belford Road,
Edinburgh, EH4 3UE.
Tel. 0131 247 2000

Health and Safety Executive Information Line
Tel. 0870 154 5500



Standards organisations

British Standards Institution
Head office: 2 Park Street,
London W1A 2BS .

Publications:
Linford Wood,
Milton Keynes MK14 6LE.
Tel. 01908-221 166.

European Committee for Standardization,
Rue de Stassart 36, B-1050 Brussels

Other organisations

Association of Consulting Engineers,
Alliance House, 12 Caxton Street,
London SW1 H 0QL.
Tel. 0171-222 6557.

Institute of Healthcare Engineering and Estate Management ,
2 Abingdon House, Cumberland Business Centre,
Northumberland Road,
Portsmouth PO5 1 DS.
Tel. 02392-823186.

Institution of Electrical Engineers,
Publication Sales Department, PO Box 26,
Hitchin,
Hertfordshire SG5 1SA.
Tel. 01438-742792.

Institution of Mechanical Engineers, Publication Sales Department,
PO Box 24, Northgate Avenue,
Bury St Edmunds,
Suffolk IP32 6BW.
Tel. 01284-763277.

Appendix 2: Information to be supplied by the manufacturer

A2.1 The following information should be supplied by the manufacturer of the sterilizer at or before the time the sterilizer is delivered.

Standards

A2.2 Statements of compliance with relevant British and European Standards and documentary evidence to demonstrate such compliance.

Instruction manual

A2.3 The manual should contain complete instructions including:

- a. simplified operating instructions in a durable form suitable for fixing next to the sterilizer;
- b. guidance on the types of load that may be processed in the sterilizer and their recommended packaging;
- c. operational limits including design pressure, maximum permissible working pressure and maximum permissible working temperature.

Instruments and controls

A2.4 The manual should include a description of each instrument and control fitted to the sterilizer including:

- a. the scale ranges of each and the limits of accuracy;
- b. evidence that the calibration of each instrument has been verified and that the instrument is reading correctly within its stated limits of accuracy.

A2.5 Where an air detector is fitted, the manual should give:

- a. the setting of the sensitivity of the air detector;
- b. the level of the signal from the airdetector which will trigger automatic controller to abort the cycle and indicate a fault;
- c. the vacuum leak rate that will cause this level to be exceeded.

Operating cycles

- A2.6 The manual should give a description of each operating cycle available on the sterilizer specifying:
- the sterilization temperatures available;
 - graphical representation of cycle variables (temperature, pressure, etc.) as a function of elapsed time for each sterilization temperature;
 - the maximum rate of change for each cycle variable;
 - the range of variation of any adjustable, preset cycle variables;
 - the cycle time and performance class for the thermometric tests for a full load described in Part 3 of this SHTM;
 - copies of the cycle records obtained during any type tests or works tests.

Services

- A2.7 The manual should give a description of all the engineering services required by the sterilizer, specifying:
- values of the fluctuating demands placed on each service during the course of a normal operating cycle;
 - the maximum and minimum safe supply pressures, temperatures and voltages.

Safety

- A2.8 Safety information should include:
- descriptions of any safety hazards that may arise in the normal operation of the sterilizer and recommended precautions to avoid them;
 - descriptions of all safety devices including their recommended settings and any means provided to override and reset them.



Chamber

- A2.9 Information about the chamber should include the following:
- a. the total volume of the chamber;
 - b. the dimensions of the usable chamber space and its capacity expressed both in litres and as an integral number of sterilization modules;
 - c. sufficient information to enable the user to identify, for an empty chamber:
 - (i) the parts of the usable chamber space that are the fastest and the slowest to attain the sterilization temperature;
 - (ii) the parts of the usable chamber space that are the hottest and the coolest during the sterilization holding time;
 - (iii) for sterilizers with a thermal door lock, the part of the usable chamber space that is the slowest to cool to a preset safe temperature (normally 80°C).

Maintenance manual

- A2.10 Two copies should be provided. It should include:
- a. a planned preventative maintenance programme consistent with the principles outlined in Part 4 of this SHTM together with detailed instructions for the procedures contained within it;
 - b. a list of any information to enable the user to identify, for an empty and testing;
 - c. diagrams of all electrical, steam, compressed air, water and gas systems;
 - d. a complete list of spare parts, indicating all parts which should be held in stock and that may require replacement during the normal working life of the sterilizer together with their likely usage rates;
 - e. guidance on tracing and rectifying likely causes of malfunction;
 - f. procedures for door safety control checks together with the sequence of operation;
 - g. method of calibrating the pressure, temperature and humidity indicating and recording systems.