

STATUS IN NHSSCOTLAND
BEST PRACTICE GUIDANCE

Health Building Note 00-04

Core elements:

Circulation and communication spaces

For queries on the status of this document contact
nss.hfsenquiries@nhs.net or telephone 0141207 1600

Status Note amended 14th October 2014

DOH Document Code Part - DOH Document Title and Name

This document must be read in conjunction with current Scottish Government Policy and NHSScotland Guidance, which take precedence. These include publications in both: www.sehd.scot.nhs.uk/ and www.hfs.scot.nhs.uk/publications/.

Specific updates for NHSScotland use:**Chapter No**

Para No

Core elements

Health Building Note 00-04: Circulation and communication spaces



Health Building Note 00-04

Circulation and communication spaces

© Crown copyright 2013

Terms of use for this guidance can be found at <http://www.nationalarchives.gov.uk/doc/open-government-licence/>

Preface

About Health Building Notes

Health Building Notes give “best practice” guidance on the design and planning of new healthcare buildings and on the adaptation/extension of existing facilities.

They provide information to support the briefing and design processes for individual projects in the NHS building programme.

The Health Building Note suite

Healthcare delivery is constantly changing, and so too are the boundaries between primary, secondary and tertiary care. The focus now is on delivering healthcare closer to people’s homes.

The Health Building Note framework (shown below) is based on the patient’s experience across the spectrum of care from home to healthcare setting and back, using the national service frameworks (NSFs) as a model.

Health Building Note structure

The Health Building Notes have been organised into a suite of 17 core subjects.

Care-group-based Health Building Notes provide information about a specific care group or pathway but cross-refer to Health Building Notes on **generic (clinical) activities** or **support systems** as appropriate.

Core subjects are subdivided into specific topics and classified by a two-digit suffix (-01, -02 etc), and may be further subdivided into Supplements A, B etc.

All Health Building Notes are supported by the overarching Health Building Note 00 in which the key areas of design and building are dealt with.

Example

The Health Building Note on accommodation for adult in-patients is represented as follows:

“Health Building Note 04-01: Adult in-patient facilities”

The supplement to Health Building Note 04-01 on isolation facilities is represented as follows:

“Health Building Note 04-01: Supplement 1 – Isolation facilities for infectious patients in acute settings”

Health Building Note number and series title	Type of Health Building Note
Health Building Note 00 – Core elements	Support-system-based
Health Building Note 01 – Cardiac care	Care-group-based
Health Building Note 02 – Cancer care	Care-group-based
Health Building Note 03 – Mental health	Care-group-based
Health Building Note 04 – In-patient care	Generic-activity-based
Health Building Note 05 – Older people	Care-group-based
Health Building Note 06 – Diagnostics	Generic-activity-based
Health Building Note 07 – Renal care	Care-group-based
Health Building Note 08 – Long-term conditions/long-stay care	Care-group-based
Health Building Note 09 – Children, young people and maternity services	Care-group-based
Health Building Note 10 – Surgery	Generic-activity-based
Health Building Note 11 – Community care	Generic-activity-based
Health Building Note 12 – Out-patient care	Generic-activity-based
Health Building Note 13 – Decontamination	Support-system-based
Health Building Note 14 – Medicines management	Support-system-based
Health Building Note 15 – Emergency care	Care-group-based
Health Building Note 16 – Pathology	Support-system-based

Other resources in the DH Estates and Facilities knowledge series

Health Technical Memoranda

Health Technical Memoranda give comprehensive advice and guidance on the design, installation and operation of specialised building and engineering technology used in the delivery of healthcare (for example medical gas pipeline systems, and ventilation systems).

They are applicable to new and existing sites, and are for use at various stages during the inception, design, construction, refurbishment and maintenance of a building.

All Health Building Notes should be read in conjunction with the relevant parts of the Health Technical Memorandum series.

Activity DataBase (ADB)

The Activity DataBase (ADB) data and software assists project teams with the briefing and design of the healthcare environment. Data is based on guidance given in the Health Building Notes, Health Technical Memoranda and Health Technical Memorandum Building Component series.

1. Room data sheets provide an activity-based approach to building design and include data on personnel, planning relationships, environmental considerations, design character, space requirements and graphical layouts.
2. Schedules of equipment/components are included for each room, which may be grouped into ergonomically arranged assemblies.
3. Schedules of equipment can also be obtained at department and project level.
4. Fully loaded drawings may be produced from the database.
5. Reference data is supplied with ADB that may be adapted and modified to suit the users' project-specific needs.

Note

The sequence of numbering within each subject area does not necessarily indicate the order in which the Health Building Notes were or will be published/printed. However, the overall structure/number format will be maintained as described.

Executive summary

Health Building Note 40 – ‘Common activity spaces’ is being republished into three documents. This document forms Health Building Note 00-04 and covers ‘circulation and communication spaces’.

Circulation spaces provide access within hospital departments whereas communication spaces provide access between departments and may include main hospital streets.

This document provides guidance on the design of circulation and communication spaces in hospitals and other healthcare buildings, including corridors, internal lobbies and stairs, and lifts. It also provides supporting information on doors and handrails.

The spaces described allow for the movement of ambulant and semi-ambulant people (including those using crutches, sticks and walking frames) and wheelchair users. Requirements for bed and patient trolley movement are also described.

The guidance is based on ergonomic research, including a study that investigated space requirements for bed movement along corridors and through doors.

In places, the guidance differs from that provided in Approved Document M (2013) and BS 8300:2009+A1:2010. Where this is the case, the reasons for the variations are discussed.

The 2013 version of HBN 00-04 references the 2013 edition of Approved Document M: Access to and Use of

Buildings, which incorporates text amendments made to reflect any changes arising as a result of the Building Regulations 2010 and 2013 amendments. There have been no amendments to the substantive requirements in Schedule 1 (that is, Parts A to P) of the Building Regulations. Some of the main 2013 amendments reflect changes to:

- general guidance on materials and workmanship and the Construction Products Directive;
- references relating to the Equality Act 2010 and Equality Act 2010 (disability);
- simplification of general guidance for stairs and ramps that do not form part of the external principal entrances and alternative accessible entrances;
- updated guidance on access statements, door opening forces, changing places and toilets;
- updated guidance on guarding and handrails, and manifestation for glass doors and glazed screens moved to Approved Document K.

BS 8300:2009+A1:2010 looks at the design of buildings and their ability to meet the requirements of disabled people. It looks at how some facilities, such as corridors, car parks and entrances, can be designed to provide aids for the disabled. It also demonstrates how additional features, including ramps, signs, lifts and guard rails, can be installed.

Acknowledgements

G Beesley, Institute of Healthcare Engineering and Estate Management (IHEEM)

Professor Keith Bright, access consultant, Keith Bright Associates

Robert Feeney, ergonomist, Robert Feeney Associates

Chris Fielding, Royal National Institute for the Blind

Mike Finbow, consultant, NBAT

Arthur Goldthorpe, ex-chairman of Access England

Dr Sue Hignett, healthcare ergonomics and patient safety research unit, Loughborough University

Jean Lawrence, Infection Control Nurses' Association

Alison McCree, national secretary, Health Facilities Management Association (HeFMA)

Stewart McGough, regional manager, Aedas Access Consultancy

Robert Montgomery, strategic estates advisor

Peter Monk, Hammersmith & Fulham Council access officer and member of BS 8300 technical committee

NHS Security Management Service

Baldev Patel, committee manager, standards development, BSI

Dr Patricia Pay, chair of BS technical committee B/559 – 'Access for disabled people'

David Petherick, principal architect, sustainable buildings division, Department of Communities and Local Government (DCLG)

Judith McNulty-Green, health and social care services unit, Health & Safety Executive

Geoff Ridgway, senior medical officer

David Rowley, architect, Nightingale Associates

Dr Robert Spencer, chairman, Hospital Infection Society

John Temple, architect, Temple Associates

Welsh Health Estates

Contents

Preface	About Health Building Notes The Health Building Note suite Health Building Note structure Other resources in the DH Estates and Facilities knowledge series Health Technical Memoranda Activity DataBase (ADB)	
Executive summary		
Acknowledgements		
Contents		
1 Introduction		1
	Health Building Note 00 series of documents Purpose and scope of this document Supporting Health Building Notes Evidence base Dimensions	
2 General design and functional considerations		3
	Statutory and other requirements Wayfinding Visual and colour contrast Wall and floor finishes Access and security	
3 Corridors		5
	Introduction Corridor width Corridor width for general traffic Corridor width for bed/patient trolley traffic Obstructions Doors Lighting Security Handrails	
4 Internal lobbies		16
	Introduction Lobby size Lobby width Lobby length Doors Surfaces Lighting	
5 Internal stairs		23
	Introduction Approach and landings Height	

	Risers and goings	
	Nosings	
	Edge protection	
	Step finishes and type	
	Areas under stairs	
	Handrails	
	Clear width of steps	
	Lighting	
	Ramps	
	Mattress evacuation	
6 Lifts		27
	Introduction	
	Selection of lifts	
	Lift size	
	General traffic lifts	
	Lifts for trolley/stretchers movement	
	Lifts for bed movement	
	Lift landings and lobbies	
	Lift finishes	
	Lighting	
	Doors	
7 Handrails		32
	Introduction	
	Shape and size	
	Clearance	
	Height	
	Withstandable force	
	Provision on stairs, ramps and landings	
	Provision in corridors	
	Handrails in association with wall protection	
	Balustrades	
	Appearance/finishes	
8 Doors		35
	Introduction	
	Approach	
	Threshold	
	Door opening width	
	Single doors	
	Leaf and a half doors	
	Double doors	
	Force to open door/door closers	
	Fire doors	
	Door handles	
	Pull handles	
	Handles for latching doors	
	Sliding doors	
	Automatic doors	
	Glazing	
	Kick plates	
	Visual contrast	
	Privacy curtains	
	Door signage	
Appendix 1 – Bed movement study		44

Appendix 2 – Variations from Approved Document M and BS 8300	45
Corridor widths for general traffic	
Lobby length/size	
Internal stair tread	
Internal stairs, number of risers in flights	
Visual warnings, change in level	
Lifts	
Handrails	
Door access space	
Doors opening into corridors	
Appendix 3 – References	47
Statutory/other requirements	
Department of Trade and Industry publications	
DH Estates and Facilities Policy Division publications	
Other	
Appendix 4 – Additional ergonomic studies	48

1 Introduction

Health Building Note 00 series of documents

- 1.1 Health Building Notes give “best practice” guidance on the design and planning of new healthcare buildings and on the adaptation/extension of existing facilities.
- 1.2 Core subjects are divided into specific topics and classified by a two-digit suffix and may be further subdivided into Supplements A, B etc. The Health Building Note 00 suite covers the core elements of healthcare buildings.

Purpose and scope of this document

- 1.3 This document provides evidence-based best practice guidance on the design of circulation and communication spaces in healthcare buildings that are intended to be safe, accessible and fit for purpose.
- 1.4 It includes design information on corridors, internal lobbies, internal stairs, lifts, handrails and doors that allow for the circulation of general traffic (see paragraphs 1.13–1.15), beds (see [paragraphs 1.16–1.17](#)) and patient trolleys.
- 1.5 Circulation spaces are corridors, internal lobbies etc within a department for moving between rooms/spaces within that department. Communication spaces are hospital streets, corridors, internal lobbies, staircases etc that provide access between departments.
- 1.6 Although primarily applicable to new buildings, the recommendations contained within this Health Building Note should also be applied, where practical, when existing facilities are being upgraded.

Supporting Health Building Notes

- 1.7 Where special departmental requirements warrant a variation from the spaces described in this document, information is provided in the relevant Health Building Note.

Evidence base

- 1.8 This document is based on ergonomic research (published and unpublished) and the professional opinion of experts from the fields of architecture, ergonomics and nursing.
- 1.9 Many of the recommendations relating to the anthropometry of disabled people and their space requirements are based on (unpublished) research commissioned by the Department of the Environment and carried out by Robert Feeney Associates between 1997 and 2001 in support of BS 8300:2001.
- 1.10 The recommendations relating to bed movement in corridors and through doors is based on a bed movement study commissioned by the Department of Health (DH) and carried out by Robert Feeney Associates. See [Appendix 1](#) for details.
- 1.11 Research/studies undertaken by Robert Feeney Associates were informed by anthropometric and strength measurement data from ‘ADULTDATA – The handbook of adult anthropometric and strength measurements’ (Department of Trade and Industry).

Dimensions

- 1.12 All dimensions are in millimetres. The meaning of the abbreviation “ecw” used in the drawings is “effective clear width”.
- 1.13 Spaces for general traffic allow for the circulation of ambulant and semi-ambulant people (including those using crutches, sticks and walking frames) and wheelchair users.
- 1.14 The dimensions for wheelchair circulation relate to a standard 8L wheelchair (see [Figure 1](#)).

Figure 1 Dimensions of an occupied 8L wheelchair

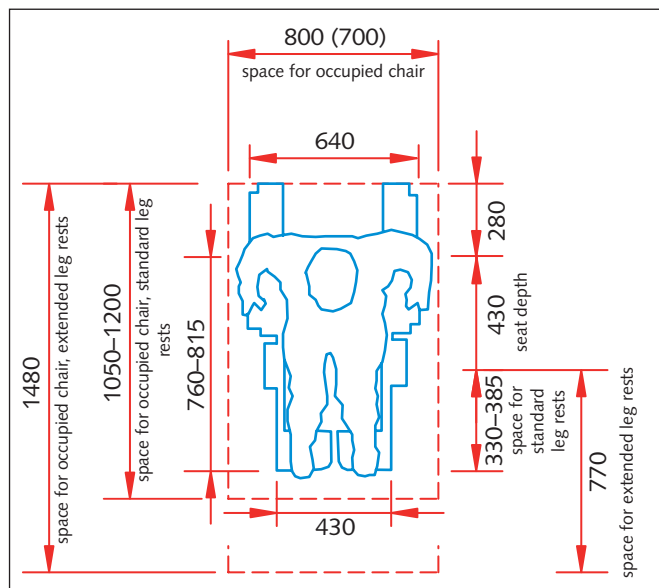

Note

The overall dimension of an occupied 8L wheelchair (approximately 1500 mm × 800 mm) is similar to the space requirements of an electrically propelled wheelchair (see table E2 in BS 8300). However, some electric scooters are larger and some wheelchairs have different proportions (for example, sports wheelchairs may be 1000 mm wide).

- 1.15 Space recommendations take account of the inexperience of some users in manoeuvring wheelchairs or using walking aids, but do not take account of the use of specialist large wheelchairs or mobility scooters.
- 1.16 Space recommendations for bed movement allow for the circulation of:
 - an extended standard hospital bed, with or without orthopaedic/other attachments, that is 2370 mm × 1000–1050 mm; and

- a bariatric bed, for patients weighing up to 450 kg (1000 lbs), that is 2330 mm × 1080 mm.

Note

Larger/wider bariatric bed usage is not covered in this Health Building Note.

- 1.17 Consideration should be given to other specialist beds that may be used.
- 1.18 The dimensions included in the example drawings may include:
 - a recommended dimension or range of dimensions;
 - a recommended minimum dimension – shown in brackets, where included.

Figure 2 Dimension standards

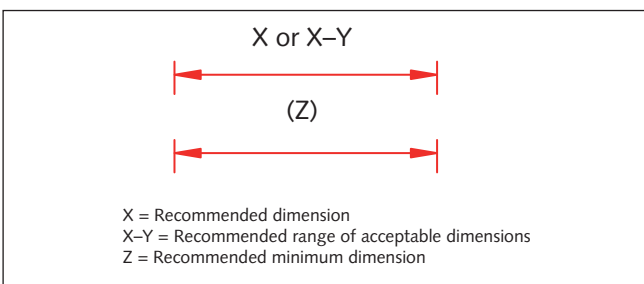

- 1.19 The dimensions for circulation widths noted and illustrated in this Health Building Note should be unobstructed, and any projections should be avoided, for example by recessing radiators and fire extinguishers.
- 1.20 Where doors open onto walls that include handrails, the dimensions provided assume that a door handle fixed at 1000 mm from the floor will pass over a handrail fixed at 900 mm from the floor. Door handles may be replaced by automatic door opening devices.

2 General design and functional considerations

Statutory and other requirements

- 2.1 This guidance has been prepared following a review of Health Building Note 40 and relevant minimum standards/recommendations in Approved Document M (2013) of the Building Regulations and BS 8300:2009+A1:2010. Building Regulations are made for specific purposes, primarily the health and safety, welfare and convenience of people and for energy conservation. Standards and other technical specifications may provide relevant guidance to the extent that they relate to these considerations. However, they may also address other aspects of performance or matters which, although they relate to health and safety etc, are not covered by the Building Regulations.
- 2.2 Where this guidance exceeds or specifically varies from BS 8300:2009+A1:2010 or Approved Document M (2013), this guidance is intended to supersede these standards for healthcare premises. See [Appendix 2](#) for details of how this guidance differs from the guidance provided by Approved Document M (2013) and BS 8300:2009+A1:2010.
- 2.3 See [Appendix 3](#) for a list of some of the main statutory requirements that relate to circulation and communication spaces.

Wayfinding

- 2.4 For information on signage see ‘Wayfinding: effective wayfinding and signing systems guidance for healthcare facilities’.

Visual and colour contrast

- 2.5 Visual contrast is as important as colour contrast, as some people with visual impairments confuse different colours of similar tone.
- 2.6 Approved Document M (2013) and BS 8300:2009+A1:2010 define visual contrast by referring to a difference in light reflectance values (LRV). Where this document refers to visual contrast, a difference in LRV as defined in Approved Document M

(2013) and BS 8300:2009+A1:2010 is recommended.

- 2.7 Floor colours should contrast visually with wall colours. Monochromatic colour schemes should be avoided.
- 2.8 Visual contrast may also be used to highlight specific features, for example lifts, stairs, doors, light switches and litter bins.
- 2.9 Contrasting handrails/crash rails may be fitted to act as navigation tools.
- 2.10 For detailed information on the use of colour and visual contrast, see:
- T21027: Dulux Trade Colour & Contrast CD;
 - Approved Document M (2103) and BS 8300:2009+A1:2010;
 - ‘Colour, contrast and perception – Design guidance for internal built environments’ (Reading University);
 - ‘Building sight’ (Royal National Institute for the Blind);
 - ‘Lighting and colour for hospital design’ (Dalke et al).

Wall and floor finishes

- 2.11 Highly-patterned walls and floors should be avoided.
- 2.12 Floor and wall surfaces should minimise light reflection.
- 2.13 Floor surfaces should be slip-resistant (whether wet or dry). See ‘Safer surfaces to walk on – reducing the risk of slipping’ (CIRIA) for further guidance on appropriate floor finishes.
- 2.14 For ease of mobility, floors and floor finishes should be firm. The use of soft coverings, such as thick carpet, should be avoided.

- 2.15 Junctions between different flooring materials should be carefully detailed so that they do not constitute an obstacle or tripping hazard.
- 2.16 All finishes and junctions between finishes (for example between walls and floors) should be easily cleanable and not support the propagation of bacteria etc.
- 2.17 See Health Building Note 00-10 Part A: 'Flooring' and Part B: 'Walls and Ceilings' for details of recommended finishes. See also 'The Healthcare Cleaning Manual' (DH) for details of best practice cleaning methods, which, along with infection

control advice, should also influence the choice of finishes.

Access and security

- 2.18 The trust's nominated local security management specialist (LSMS) should be consulted for advice and guidance on the implementation of security measures to ensure the safety of staff and security of premises.
- 2.19 Access controls should be installed to all non-public areas.

3 Corridors

Introduction

- 3.1 This chapter provides guidance on the design and appropriate width of corridors.
- 3.2 Corridors connect spaces and, in emergencies, form part of escape routes. They must be simple and safe to negotiate, and aid navigation around the building.

Corridor width

- 3.3 Corridors should be wide enough to allow two users to pass each other and negotiate doorways.
- 3.4 Where the requirements for means of escape are greater than that for circulation, for example the corridor is intended as a hospital street (see Health Technical Memorandum 05-02 – ‘Guidance in support of functional provisions for healthcare premises’), the requirements for means of escape should become the minimum requirements for the space.
- 3.5 Where passing spaces are provided, the distance between them should be determined by the frequency of activity along the corridor.
- 3.6 Potential waiting times at passing spaces (measured in seconds or number of paces) should be kept to a minimum. The average person walks at approximately 1000 mm per second, therefore a distance of 10–20 m between passing spaces is recommended.

Corridor width for general traffic

- 3.7 The recommended minimum clear corridor width for general traffic, where there is a low volume of traffic and passing spaces are provided, should be 1500 mm (see Figures 3 and 4). This width allows for varying users to pass in between the defined passing spaces (see also Figures A1 and A2 in Appendix 4) and for the approximate positioning of a 1000 mm door across the corridor (see Figure 32).

- 3.8 Where there is a higher volume of traffic, a constant clear corridor width of 1800–2100 mm will allow most users to pass comfortably (see Figures 5, 6 and 7).

Corridor width for bed/patient trolley traffic

- 3.9 The recommended minimum clear corridor width for circulation of beds/trolleys is 2150 mm if passing spaces are provided (see Figures 8 and 9).
- 3.10 Where two beds need to pass regularly, the recommended minimum clear corridor width should be 2960 mm (see Figure 10).
- 3.11 Consideration should be given to providing spaces where beds can be turned through 180 degrees particularly along long stretches of corridor and/or outside primary entrance doors or lifts (see Figure 11).

Figure 3 Space for independent wheelchair user and ambulant person to pass

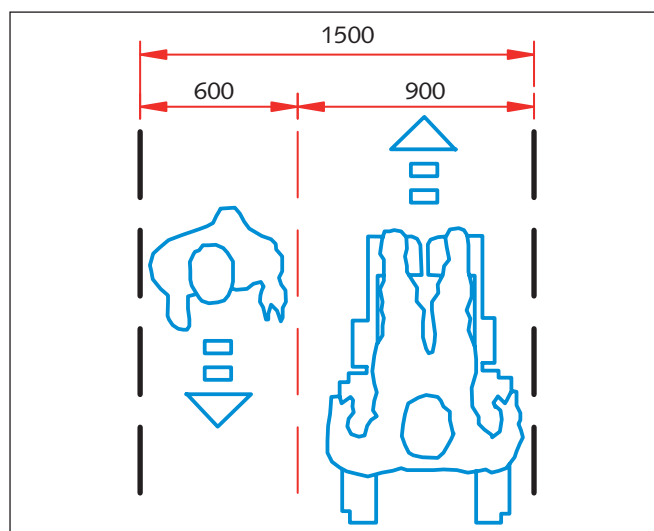

Note

Figure 11 is based on bed dimensions shown in Figures 8–10.

Figure 4 Corridor with passing space and 90 degree corner for general traffic

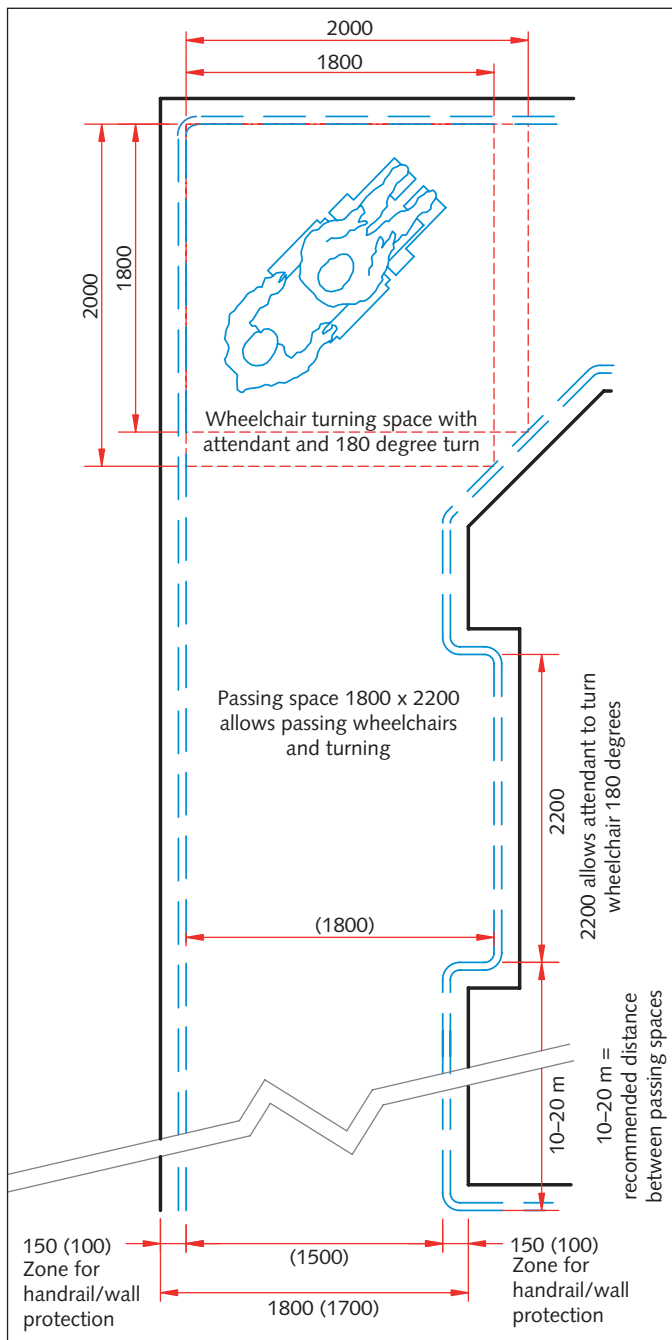

Figure 5 Space for two independent wheelchair users to pass

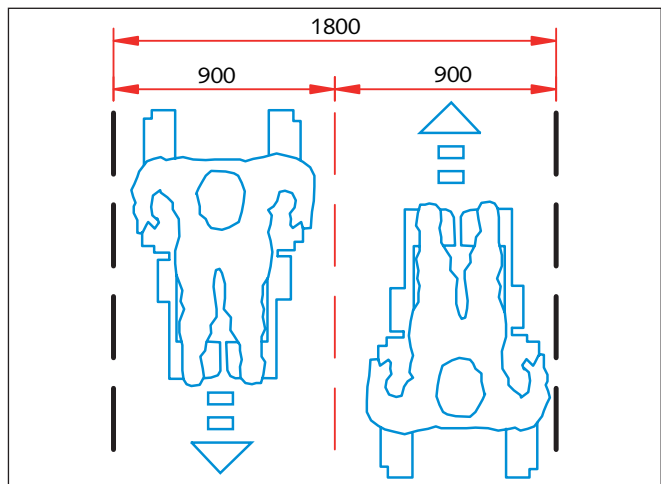

Figure 6 Space for independent wheelchair user and semi-ambulant person with walking frame to pass

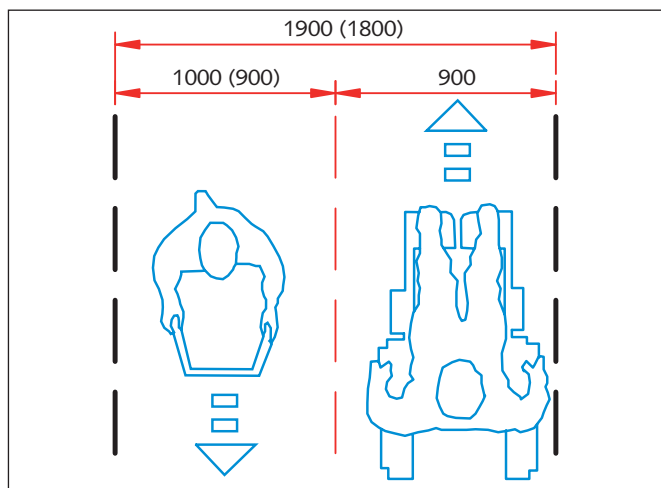

Figure 7 Space for wheelchair user and semi-ambulant user with crutches to pass

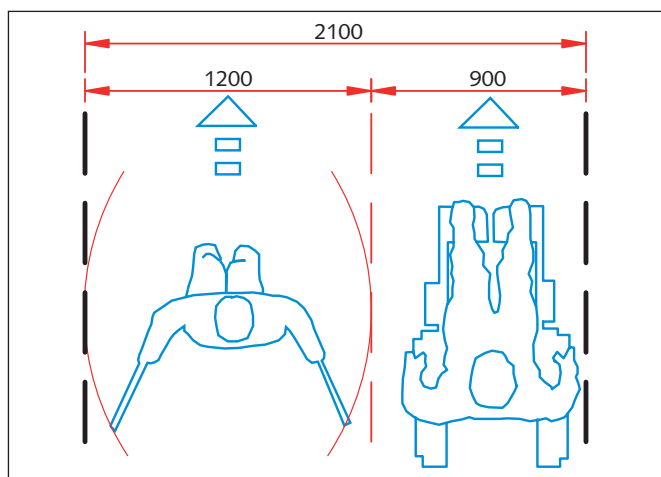

Figure 8 Space for straight bed movement

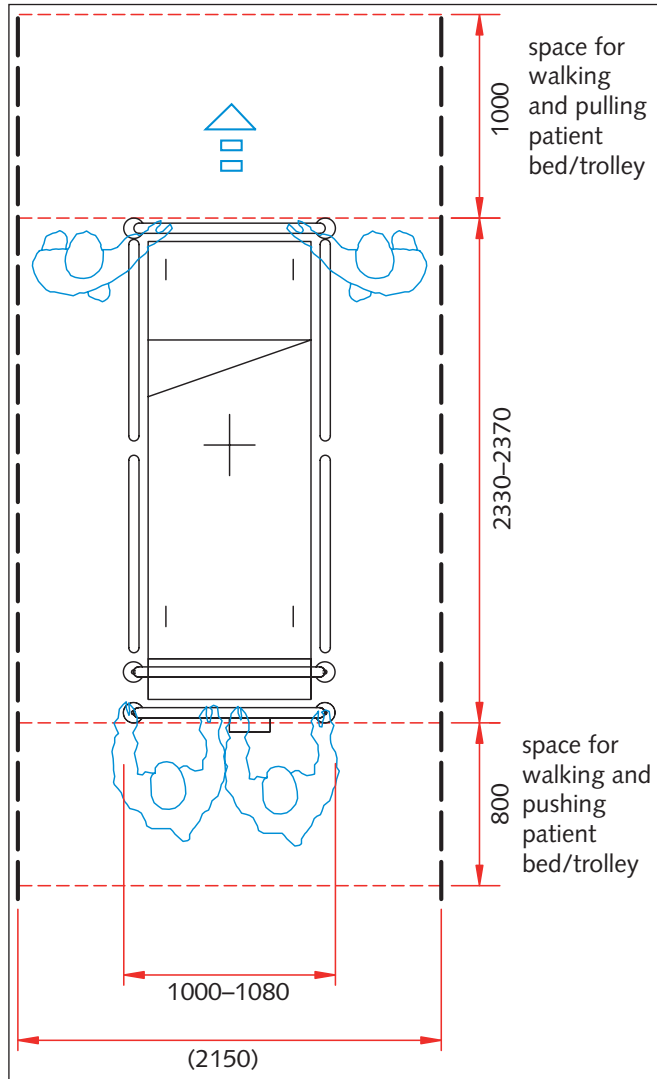

Figure 9 Bed passing space

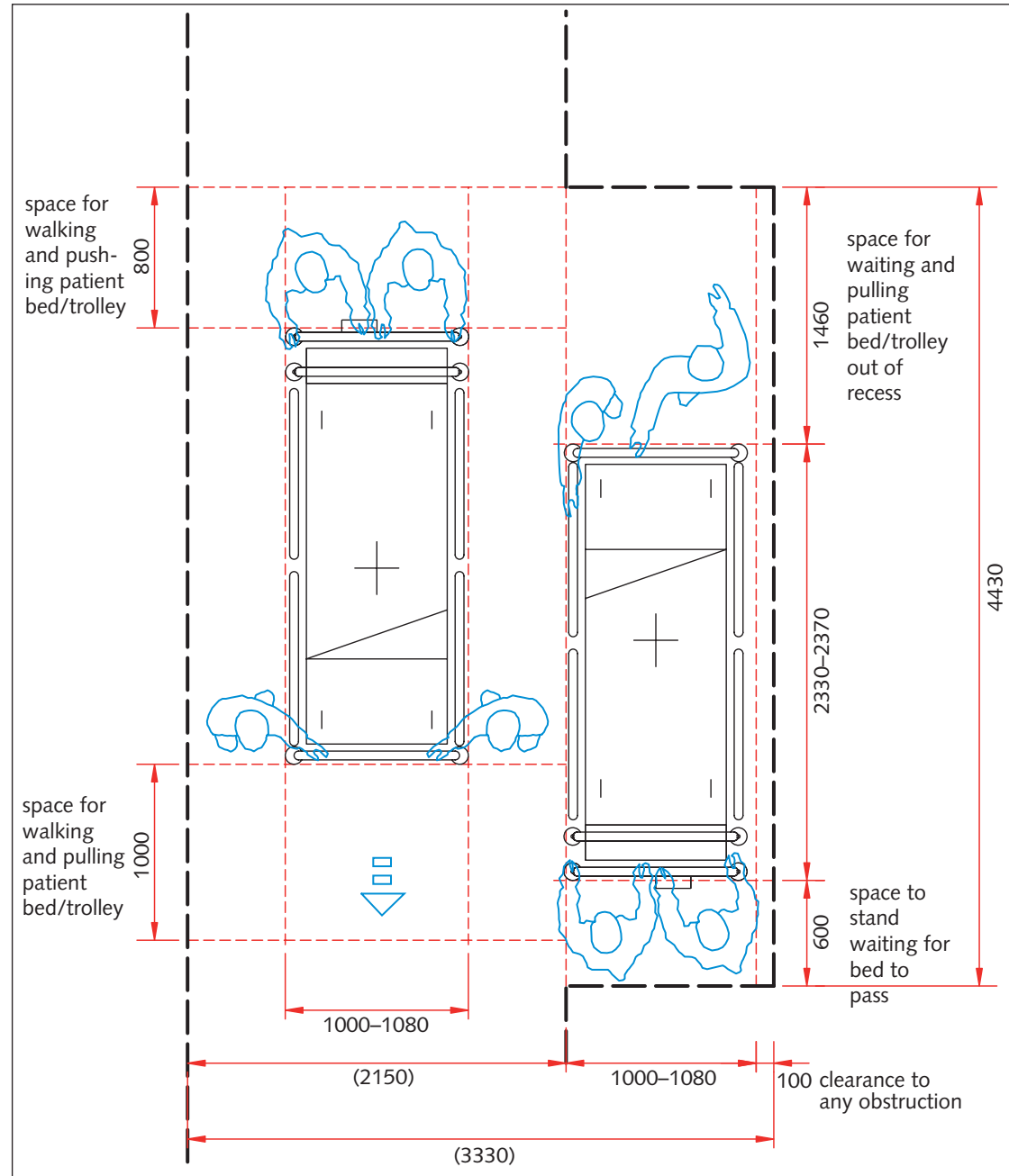

Figure 10 Space for two beds passing

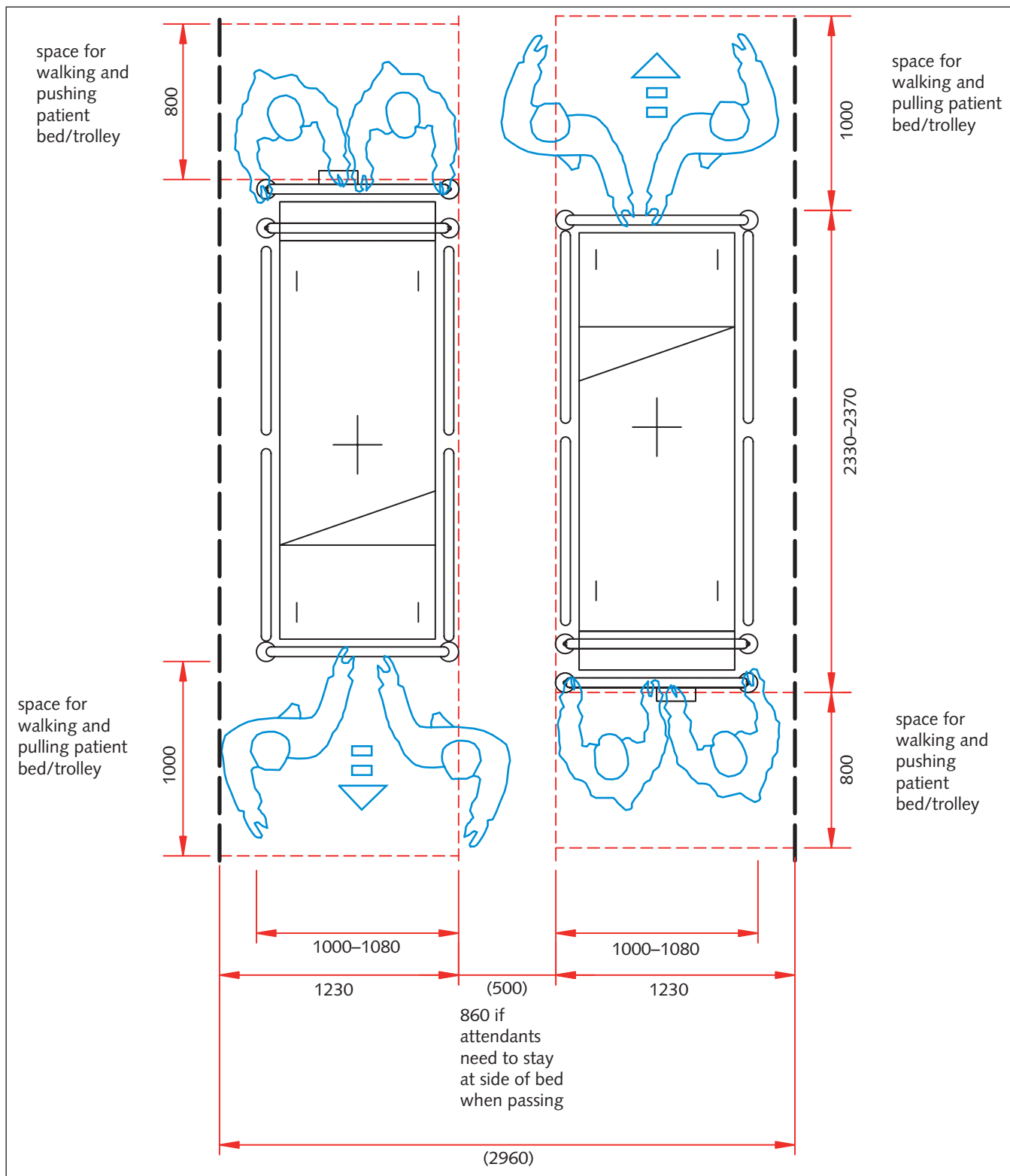
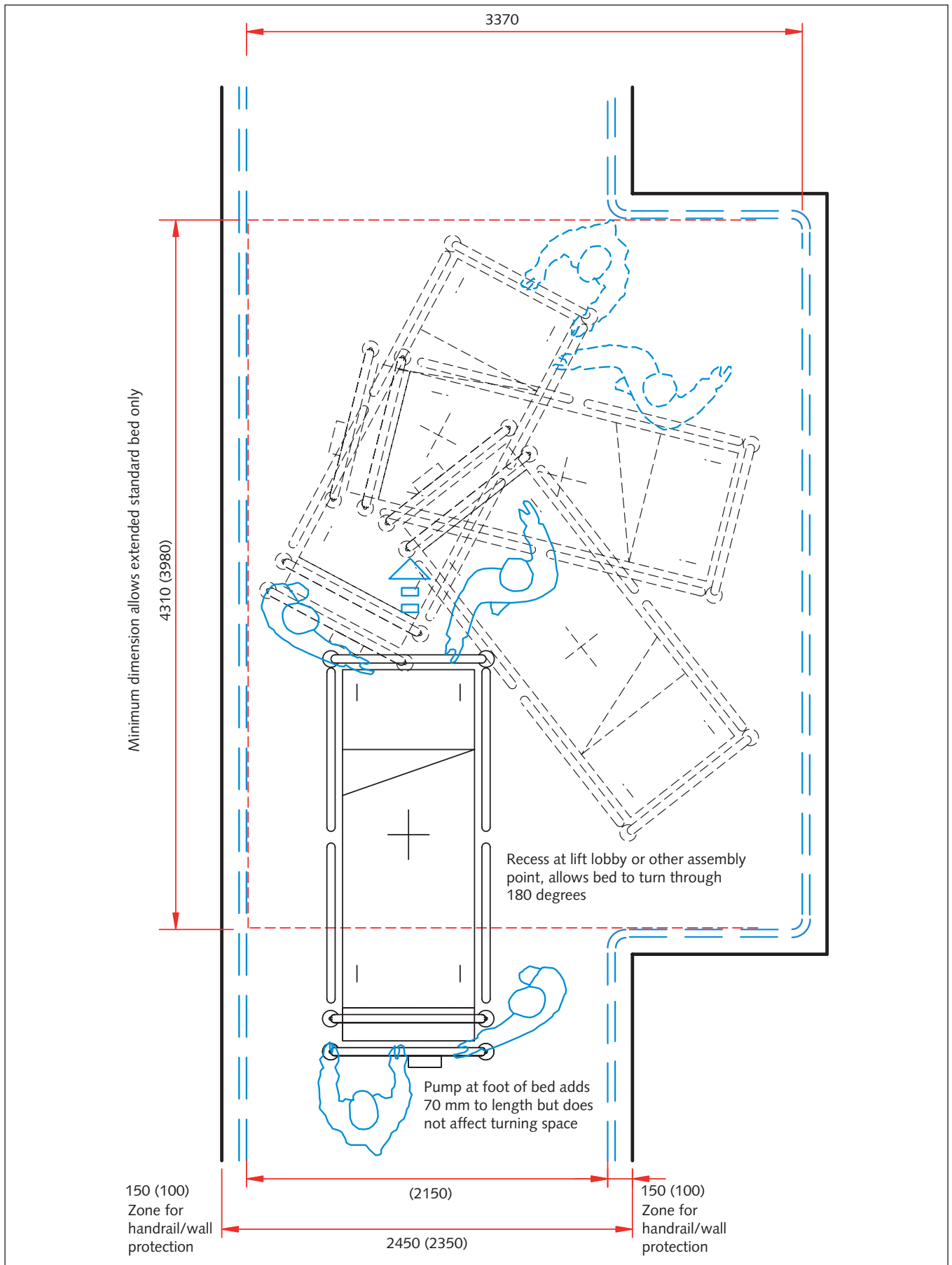

Figure 11 Corridor with recess for turning bed through 180 degrees



Obstructions

- 3.12 Sharp angles and overhead obstructions, such as staircases that jut out, should be avoided. If these exist, and cannot be removed, they should be emphasised by painting them in a bright, contrasting colour or, preferably by erecting a physical barrier (see paragraphs 5.20–5.21).
- 3.13 Corners should be carefully detailed. Splayed or rounded angles are helpful, as wall surfaces are likely to be touched by people who require a tactile knowledge of the building or use handrails for support.
- 3.14 Corridor widths should be unobstructed by projections. However, where obstructions are unavoidable (for example in existing buildings), a local reduction in clear width to 1200 mm is acceptable for general traffic corridors provided that hazard protection is installed (see Figure 12).

Doors

- 3.15 Figures 13 and 14 illustrate the minimum recommended corridor widths and single door sizes for general traffic, including turning into and out of a corridor.

- 3.16 Where doors are located within circulation routes, to help prevent partially-sighted users colliding with the door edge when the door is open or being opened, consideration should be given to stopping the handrail before it reaches the door swing area and making the last 500 mm knurled or patterned to indicate the approach of a potential hazard. See Figures 13–15 and 18–21.
- 3.17 Outward-opening doors into main circulation routes and corridors are not recommended. Where it cannot be avoided that a door opens into the corridor, the door should be recessed so that when fully open it does not restrict the clear corridor width (see Figure 14).
- 3.18 It may be acceptable to have a non-recessed door opening into a corridor provided the door gives access to a switchcupboard/service duct that is kept locked and only opened occasionally and the corridor is not on a major access or escape route (see Appendix 2).
- 3.19 Figures 15–17 illustrate the minimum recommended corridor widths and door sizes for bed movement and turning into and out of a corridor.

Figure 12 Corridor with section of restricted clear width for general traffic

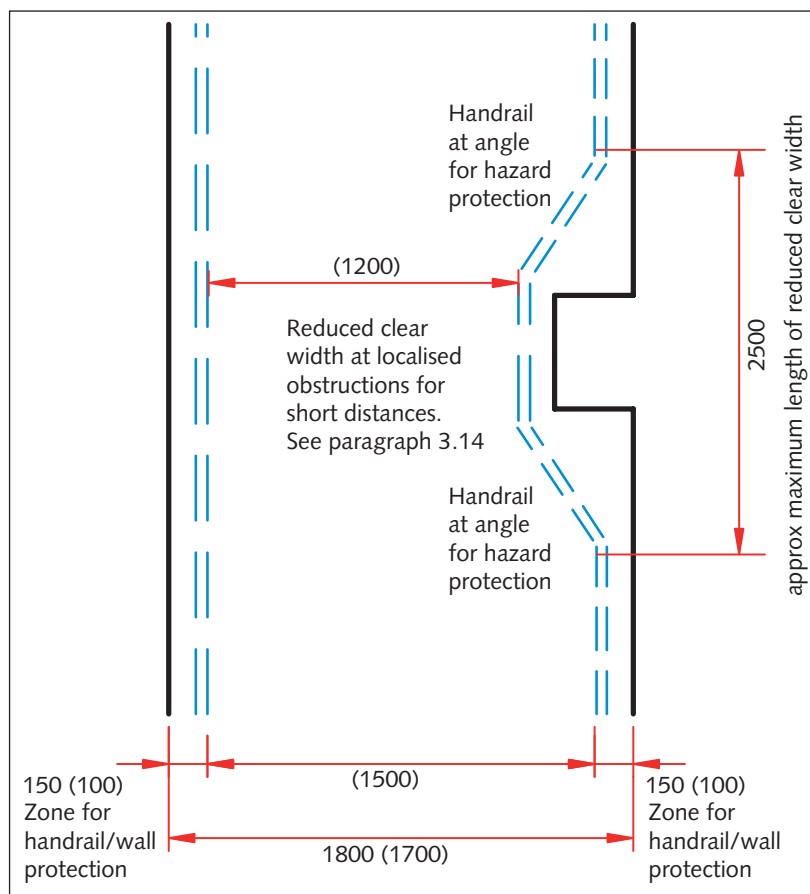

Figure 13 Straight corridor with single door for general traffic

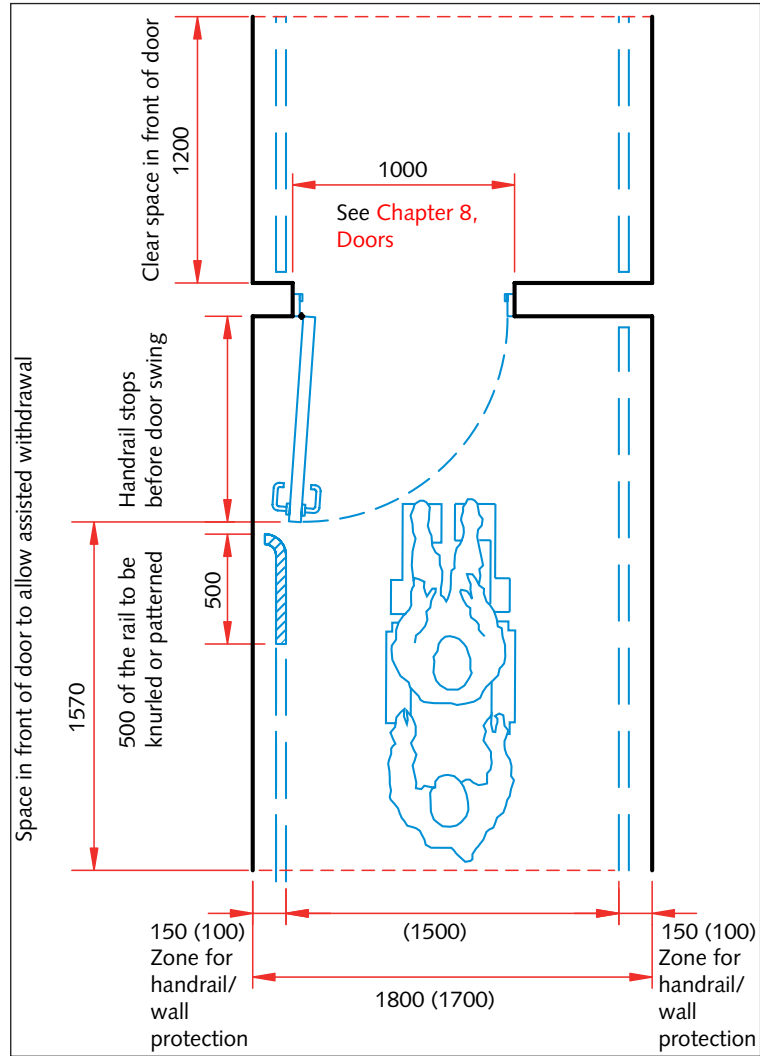

Figure 14 Corridor with single side door for general traffic

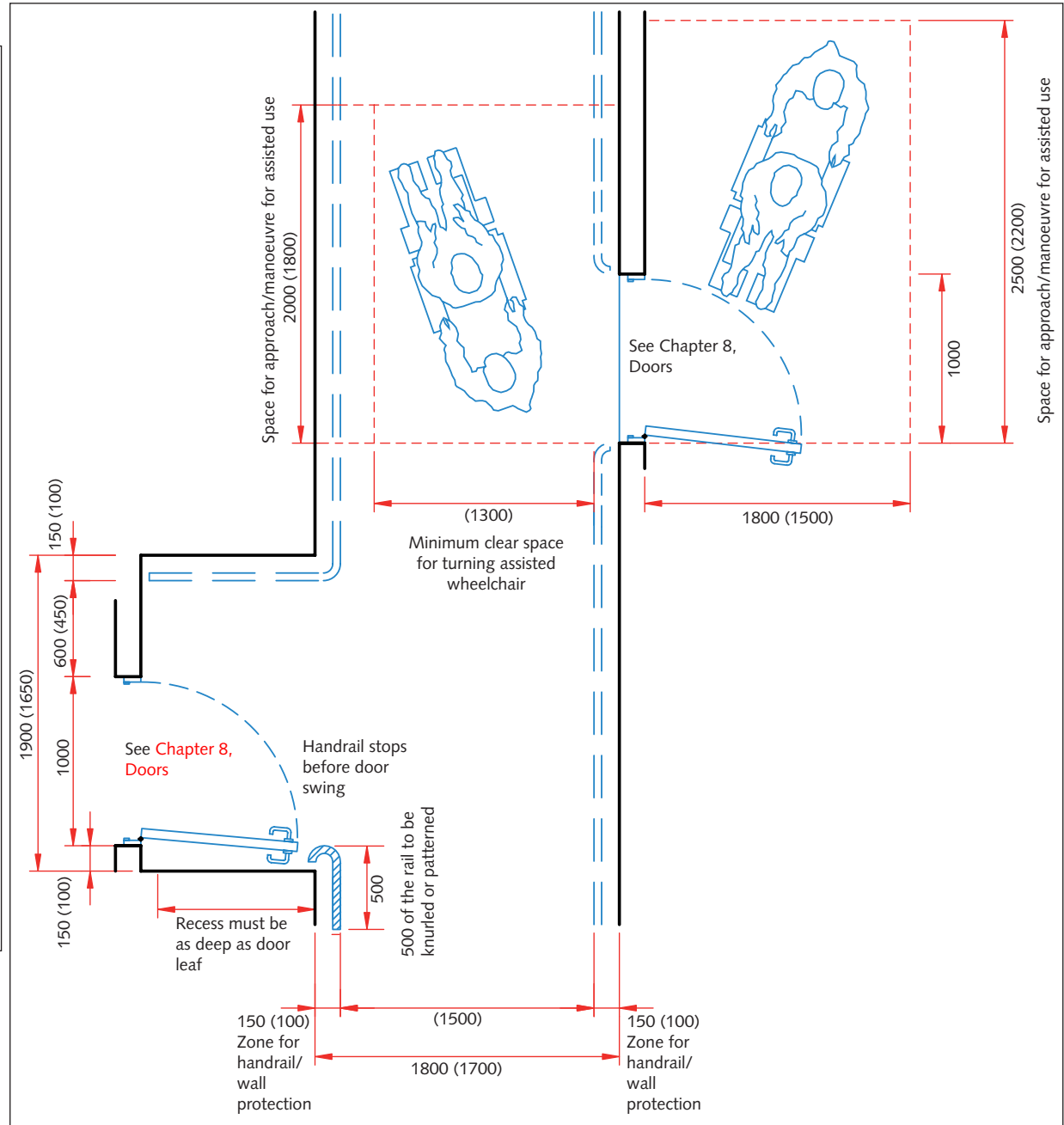

Figure 15 Straight corridor with double doors for bed movement

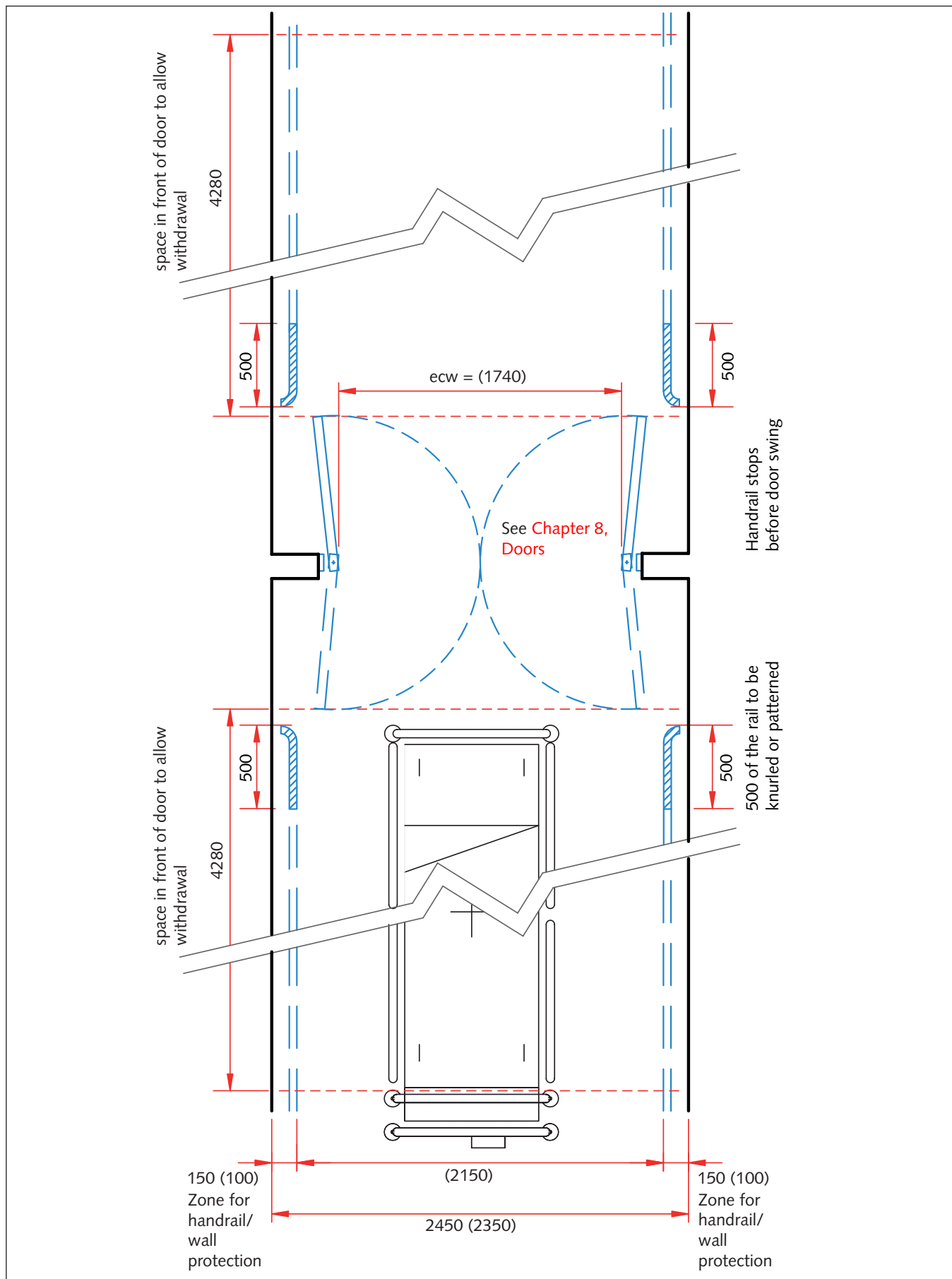

Figure 16 Turning a bed through a door off a straight corridor

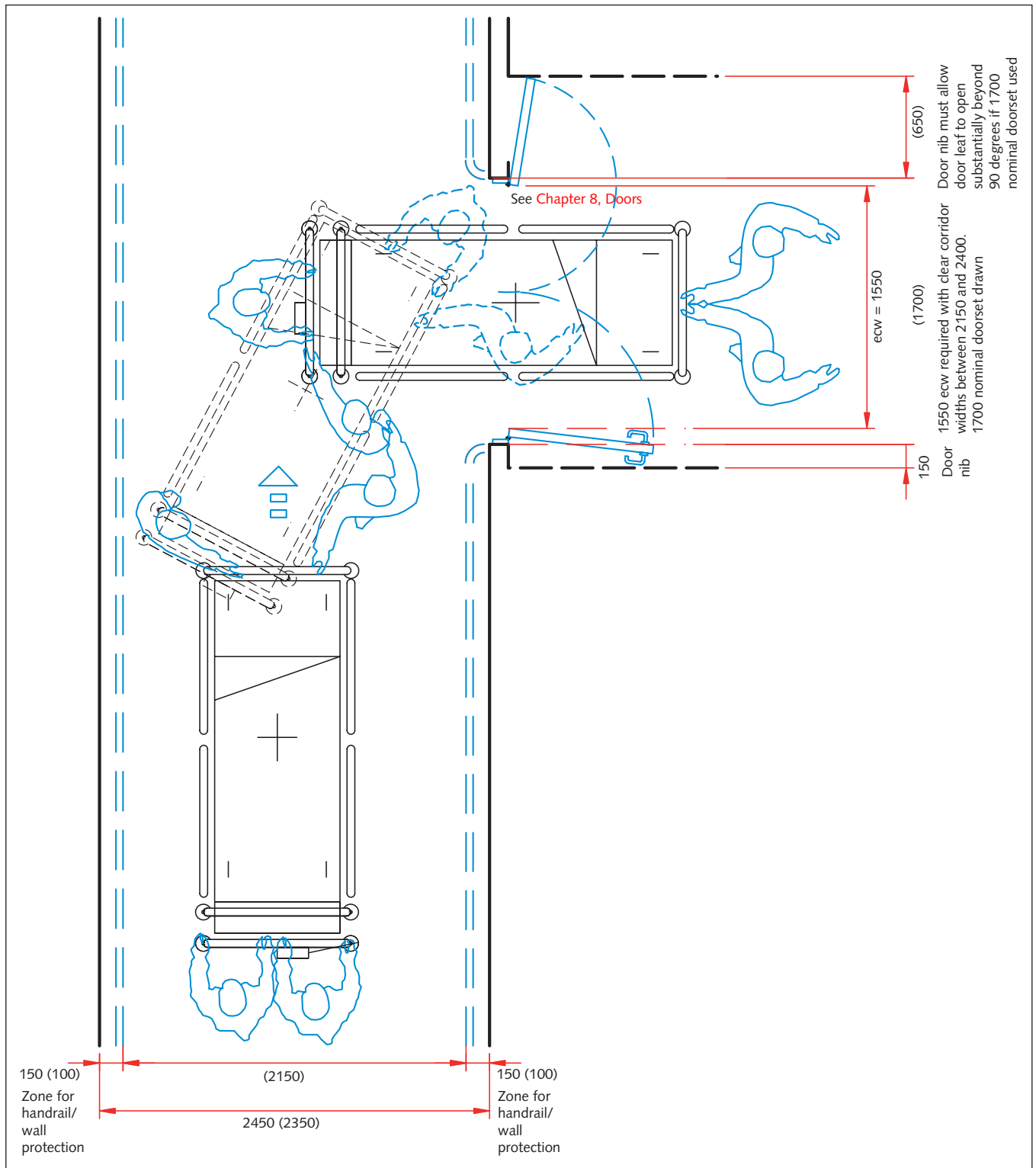
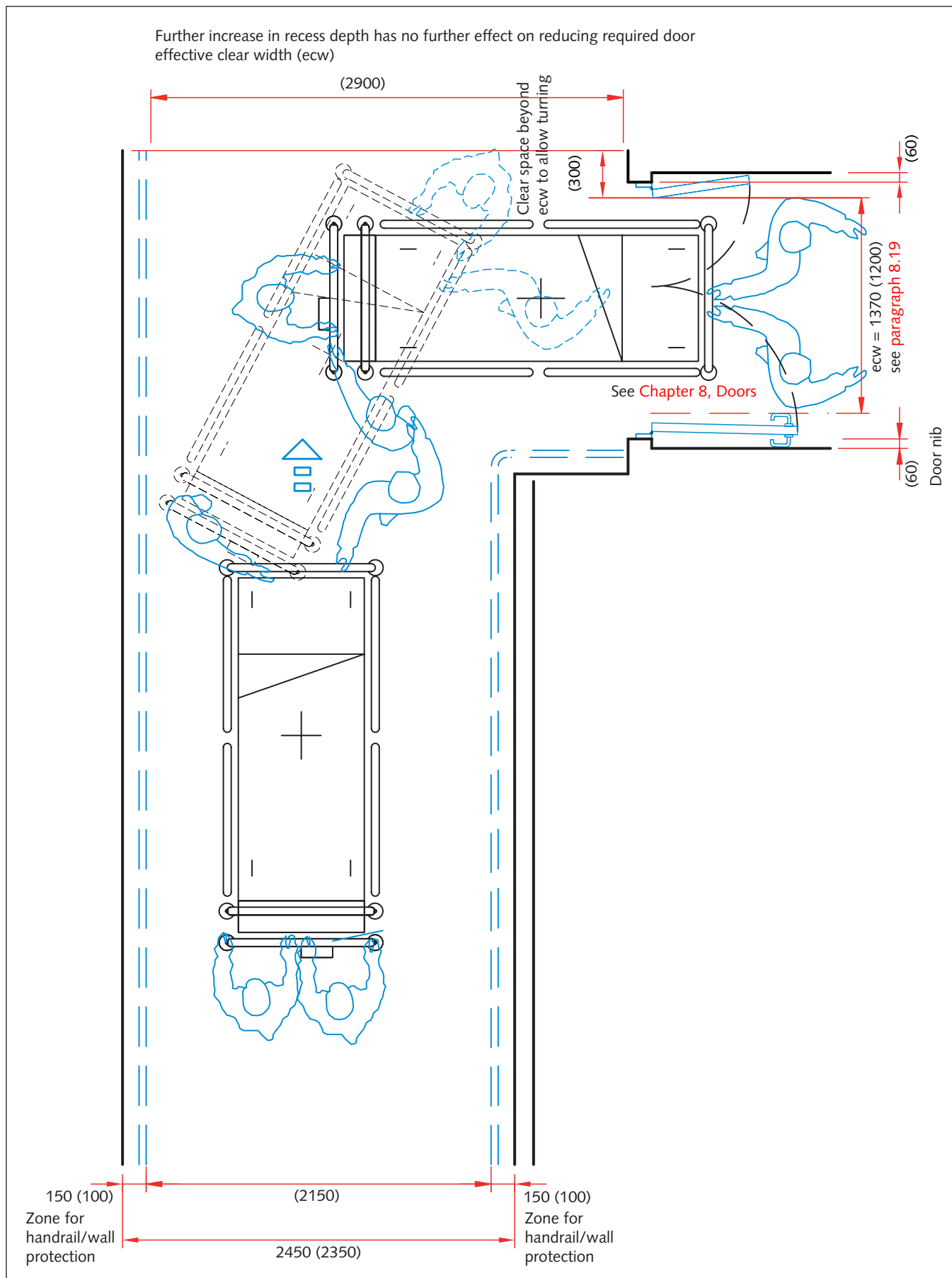

Figure 17 Turning a bed through a recessed door off a corridor



- 3.20 For guidance on the appropriate width of door leaves and required effective clear opening widths see paragraphs 8.13–8.21.

Note

Figures 15–17 are based on bed dimensions shown in Figures 8–10.

Lighting

- 3.21 Corridors should be well and evenly lit.
- 3.22 The position, size and shape of windows should maximise the use of natural light.
- 3.23 Windows should not be situated at the ends of corridors as this may produce glare.
- 3.24 Low windows can aid lighting of floor areas but should not cause glare or disorientation and should be designed to prevent people falling against or through them.
- 3.25 Glare may be minimised by using light-coloured walls and solar shading or fitting blinds or curtains.
- 3.26 Windows should open outwards and have restricted openings. Tilt-and-turn windows that protrude into corridors should be avoided.

- 3.27 Where specified, tubular fluorescent lamps and fittings should always be fitted with diffusers to minimise glare and reflection. Tubes should be positioned longitudinally down corridors to aid orientation. See the latest version of the Chartered Institution of Building Services Engineers (CIBSE) Lighting Guide 2 (LG2) – ‘Hospitals and health care buildings’ for detailed guidance on lighting.

Security

- 3.28 Corridors should be as straight as possible with limited recesses and chamfered corners to aid surveillance and security.

Handrails

- 3.29 Handrails should be fitted in main communication routes (that is, main corridors between departments) and in departmental corridors as required. See specific departmental guidance for further information.
- 3.30 All corridors should have a clear width that allows for the fitting of handrails without reducing the required clear space for access.
- 3.31 See Chapter 7 for detailed information on handrails.

4 Internal lobbies

Introduction

- 4.1 This chapter provides guidance on the design and appropriate length and width of internal lobbies (that is, lobbies connecting internal spaces, for example at staircases).
- 4.2 See also Health Technical Memorandum 05-02.

Lobby size

- 4.3 The type of traffic expected to pass through a lobby will influence the size of the lobby and the decision to provide double- or single-leaf doors.
- 4.4 Lobbies should be wide enough to allow two users to pass and to negotiate doorways. The actual width will depend upon:
- whether handrails are provided within the lobby;
 - the type of door ironmongery used and consequent nib size (see [paragraphs 8.13–8.15](#)).

Lobby width

- 4.5 For lobbies with single doors for general traffic, a minimum clear width of 1500 mm is recommended (see [Figure 18](#)). This allows for varying users passing and for the positioning of a 1000 mm doorset for access/egress. (See also [Figures A1 and A2 in Appendix 4](#) and [paragraphs 3.7–3.8](#) and [8.16](#).)
- 4.6 For lobbies with double doors for general traffic, a minimum clear width of 2020 mm is recommended (that is, 1900 mm doorset plus 60 mm door nib on either side – see [Figures 19–21](#)). See also [paragraph 8.21](#) for an explanation of door width requirements.
- 4.7 For lobbies with automatic double sliding doors for general traffic, a minimum clear width of 1500 mm is recommended (see [Figure 22](#)).
- 4.8 For lobbies with double doors (sliding or swing) for patient trolley/bed access, a minimum clear width of 2150 mm is recommended (see [Figure 23](#)). See also [paragraph 3.9](#).

Lobby length

- 4.9 Where swing doors are used, a minimum clear length (that is, clear of the furthest point that any door(s) will swing into) of:
- 1570 mm should be provided for general traffic access (see [Figures 18, 20](#) and [21](#)).
 - 4100 mm should be provided for bed/trolley access.

Note

A single swing door hinges from the corner of the door so that a 926 mm leaf swings approximately 930 mm into the lobby at its further point, depending on the hinge design. A double swing door generally hinges from part way along the door so that the leaf does not project as far when swinging.

- 4.10 For lobbies where both sets of doors are automatic sliding doors, the length can be reduced as no door swings are involved, nor is space required for manual operation. See [Figures 22](#) and [23](#).

Doors

- 4.11 Automatic sliding doors are preferred to swing doors. However, where swing doors are used, the two sets of doors at either end of the lobby should swing in the same direction, particularly for escape purposes (see [Figure 21](#)).
- 4.12 Doors may swing towards each other, or in both directions, but the lobby must be larger and ideally the doors should be offset (see [Figure 18](#)).
- 4.13 Where automatic swinging doors project more than 100 mm into access routes where users approach the door from the side (that is, not head on), the zone into which the doors open should be guarded by a barrier to protect users (see [Figures 18, 20](#) and [21](#)). See also [paragraph 3.17](#).
- 4.14 In reception areas, lobby doors should be visible from the reception desk to enable assistance to be given to anyone having difficulty negotiating the entrance.

4.15 For guidance on the appropriate width of door leaves and required effective clear opening widths see paragraphs 8.13–8.21.

Lighting

4.17 Internal lobbies should be well and evenly lit. See also paragraph 3.26.

Surfaces

4.16 Floor surfaces in lobbies should be level without thresholds at doorways.

Figure 18 Lobbies with single doors for general traffic

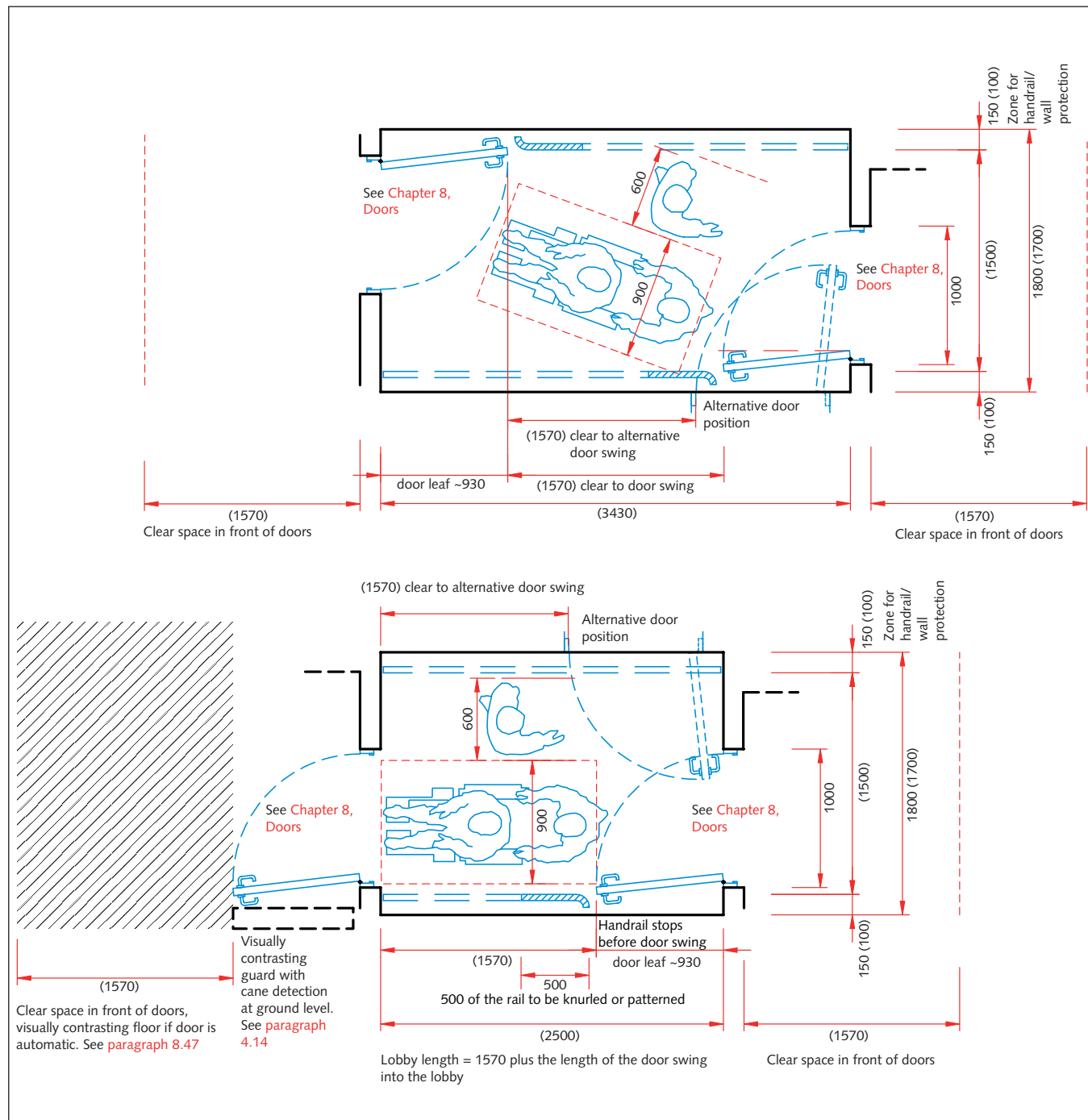

Figure 19 L-shaped lobby with double doors opening inwards for general traffic

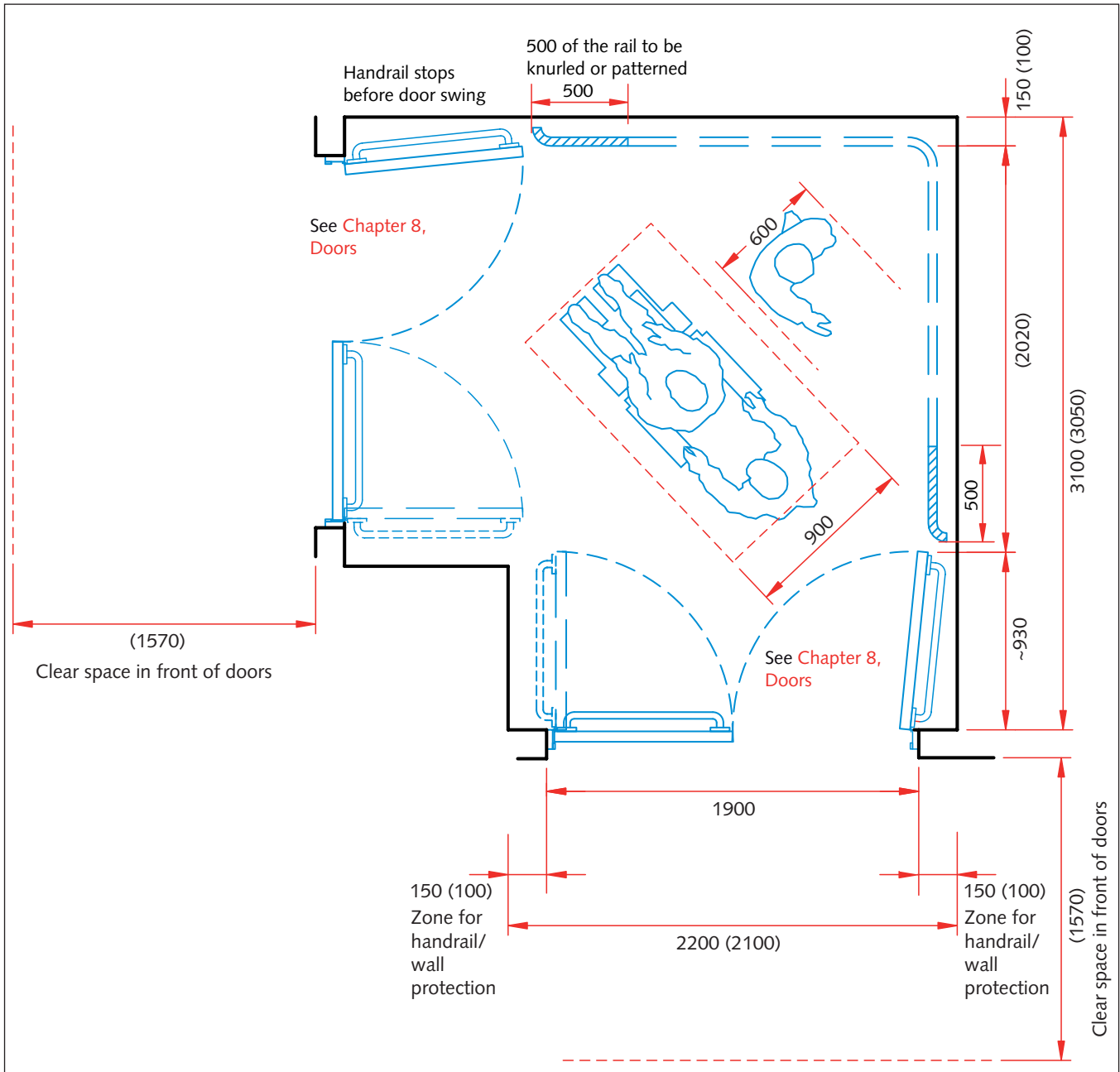

Figure 20 Lobby with double doors for general traffic

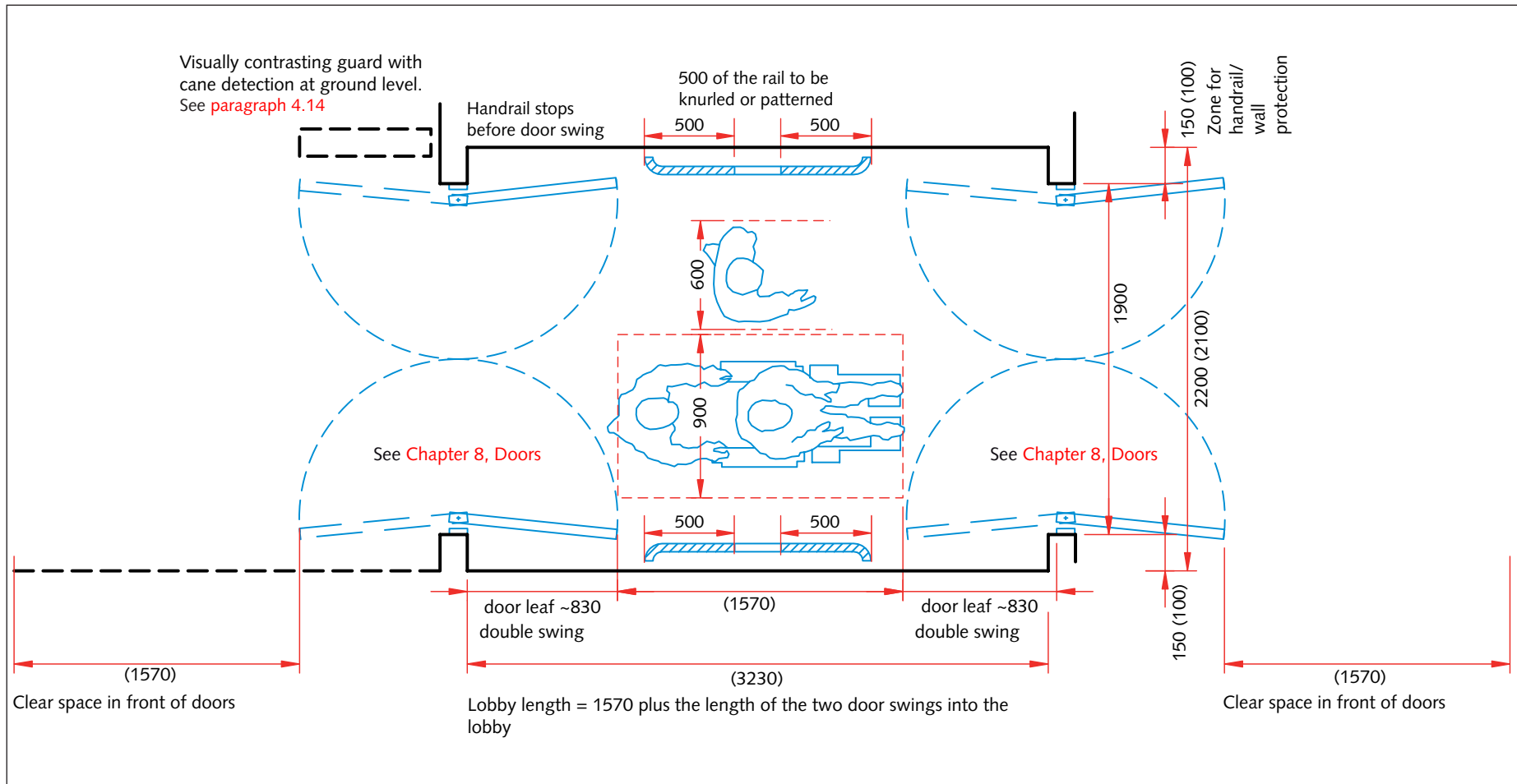

Figure 21 Lobby with double doors opening in same direction for general traffic

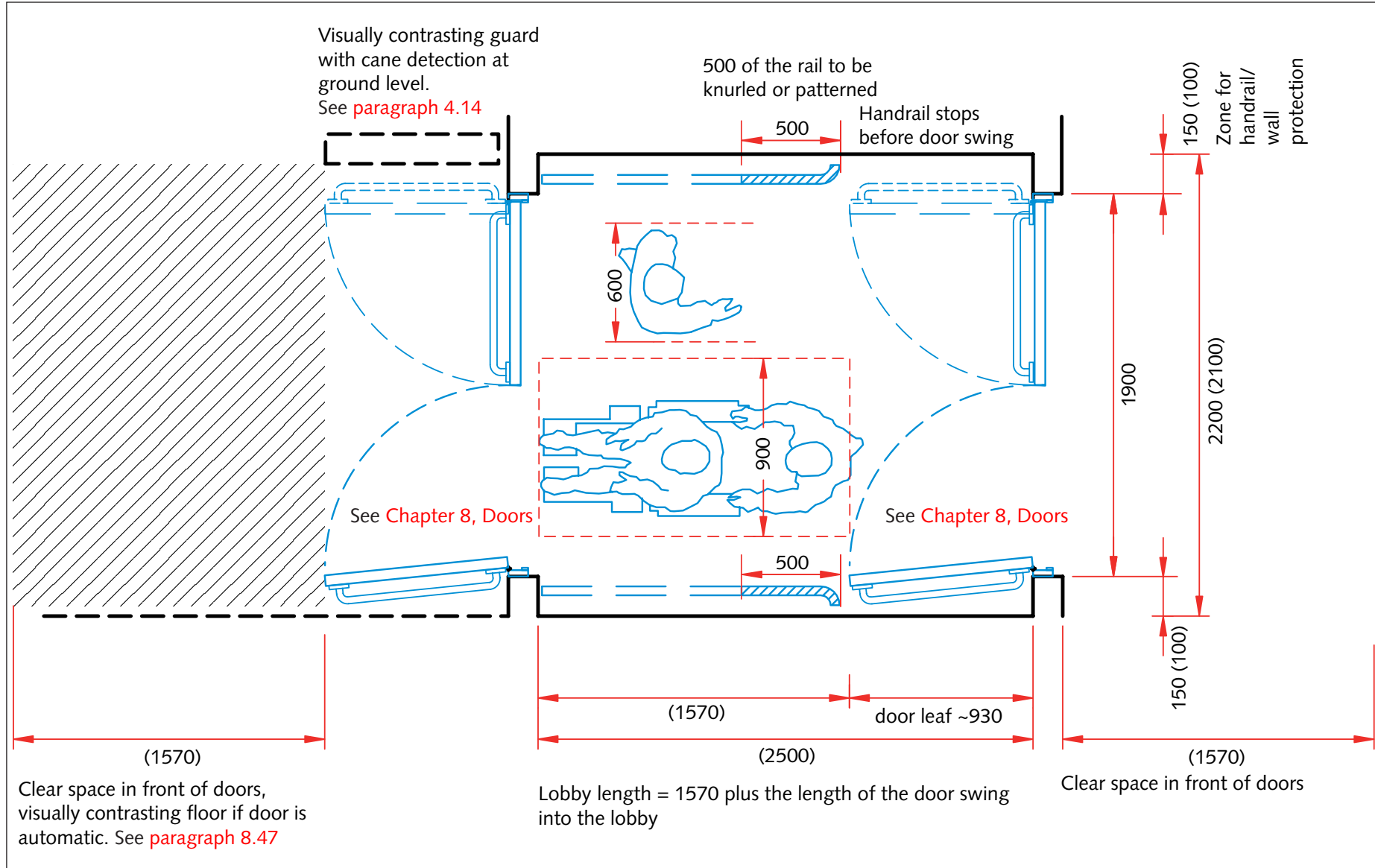

Figure 22 Lobby with automatic double sliding doors for general traffic

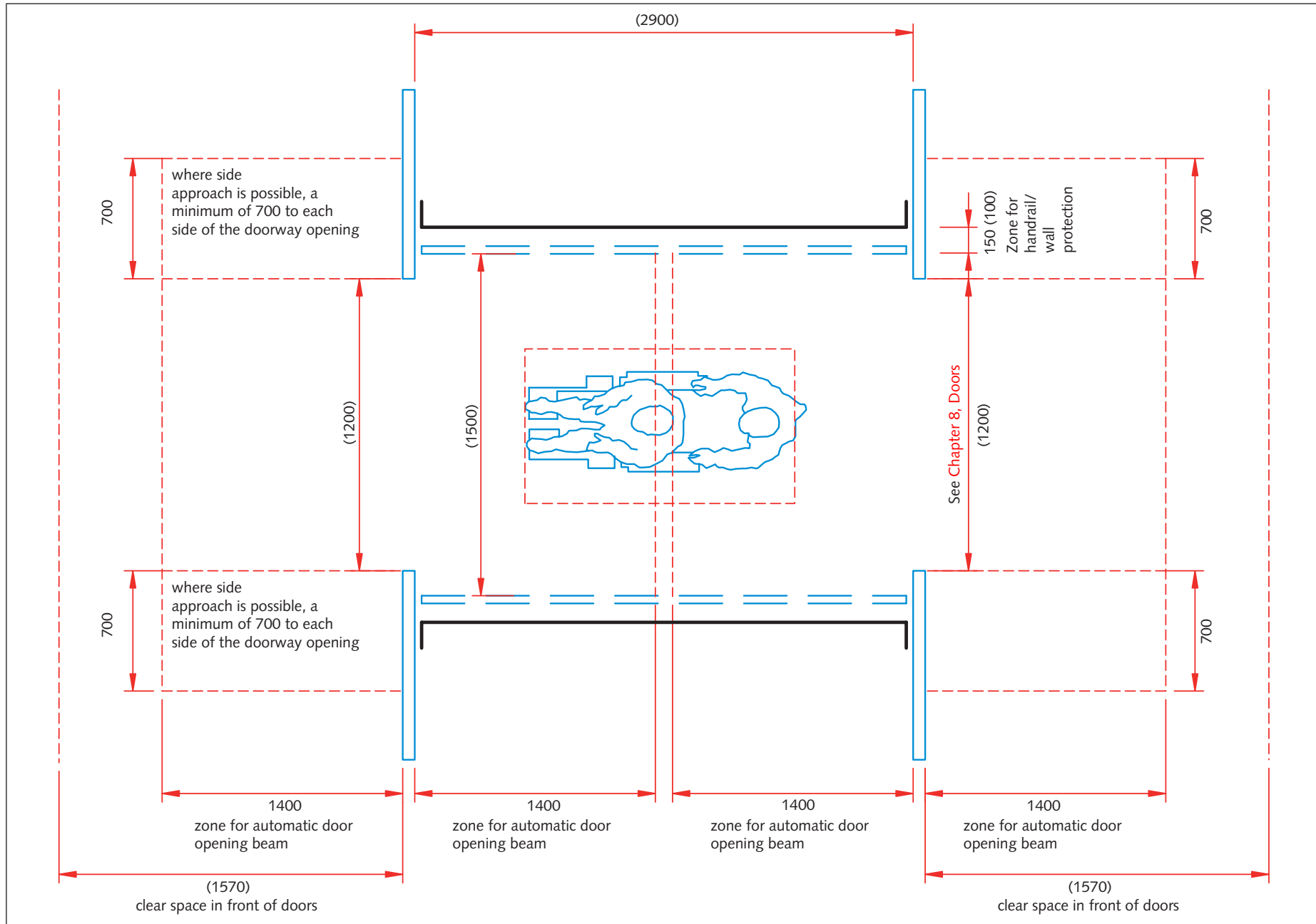
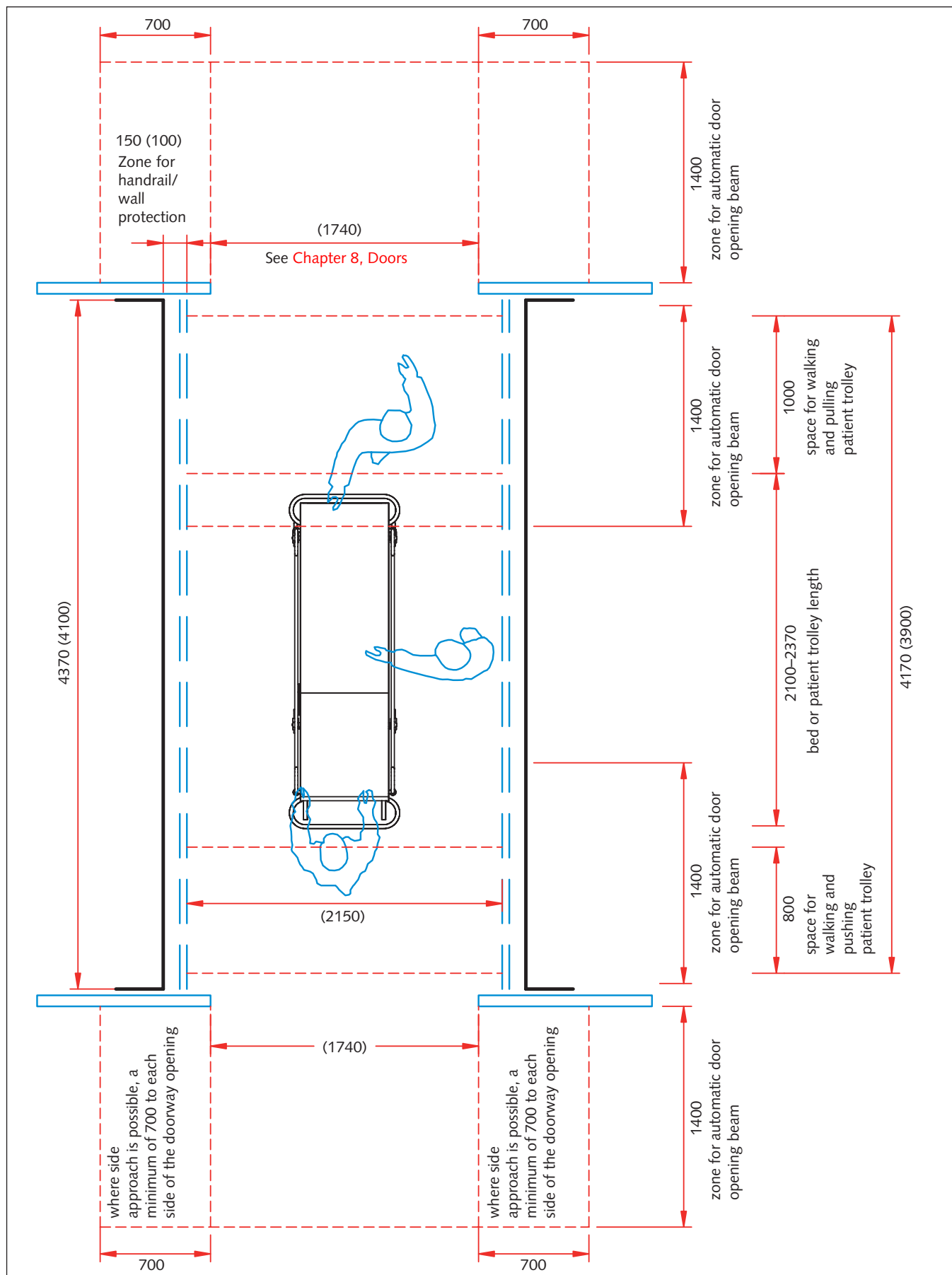

Figure 23 Lobby with automatic double sliding doors for patient trolley/bed access



5 Internal stairs

Introduction

- 5.1 This chapter provides guidance on the design of internal stairs suitable for general traffic, and for mattress evacuation.
- 5.2 Single steps may be difficult to negotiate, are not visually obvious and should be avoided.

Approach and landings

- 5.3 Stairs should be designed so that they are not in the direct line of normal pedestrian travel or access routes.
- 5.4 A landing should be provided at the top and bottom of each flight of stairs. The minimum clear landing depth is 1200 mm but must equal the clear stair width between handrails (see [paragraph 5.27](#)).
- 5.5 [Figure 24](#) shows the clear landing depth as 1500 mm to equal the example clear stair width between handrails.
- 5.6 The top and bottom steps of a flight should not encroach onto the landing area. Doors must open clear of the unobstructed clear landing.
- 5.7 To indicate that there are descending steps ahead, consideration should be given to providing a hazard-warning zone on each landing. The zone should use a floor finish that contrasts visually with the general floor finish, but has the same slip resistance.
- 5.8 The warning zone should be at least 400 mm from the nosing and a minimum of 800 mm deep and 1200 mm wide (see [Figure 24](#)). See [Appendix 2](#).

Height

- 5.9 The maximum recommended number of risers between landings for a flight of internal stairs is 12–14 (see [Appendix 2](#)).
- 5.10 Where possible, the number of risers in successive flights should be equal.

Risers and goings

- 5.11 Risers and goings should be uniform throughout the flight, as any irregularities may cause people to stumble. The recommended riser height for healthcare buildings is 150–170 mm.
- 5.12 Risers should not be of the open type, as they are a trip hazard (especially for semi-ambulant people with leg braces and prostheses), disorientating, and may transmit distracting sounds.
- 5.13 The minimum recommended length of an internal going in healthcare buildings is 280 mm, preferably 300 mm.

Nosings

- 5.14 Nosings should contrast visually with the stairs, extend the full width of the step, and reach a depth of 50–60 mm on both tread and riser to allow visually-impaired people to detect the edge of each step.
- 5.15 Although rounded nosings may cause slipping, sharp projecting nosings and abrupt angles should be avoided.
- 5.16 A tread should not overlap the one below. Where there is an overlap, the nosing should not project by more than 25 mm.

Edge protection

- 5.17 For steps not adjacent to a wall, a barrier, with a minimum height of 100 mm above the level of the treads, should be provided, for safety reasons (to prevent feet, crutches and sticks from accidentally slipping off the edge of steps).

Step finishes and type

- 5.18 Stair finishes should not have patterns that may cause step edges to be indistinguishable or cause visual confusion of any kind.
- 5.19 Helical and spiral steps, the treads of which are often too narrow, should be avoided.

Areas under stairs

- 5.20 Open areas on the underside of stairs should be avoided to eliminate the possibility of anyone walking into the overhang created.
- 5.21 If enclosure is not possible, two rails – one at 1000 mm and one at 200 mm above floor level – or some other, strategically placed, permanent barrier should be provided.

Handrails

- 5.22 Handrails should be provided on both sides of steps.
- 5.23 Handrails should be located within the width of the tread of the stairs.
- 5.24 See [Chapter 7](#) for further details on handrails.

Clear width of steps

- 5.25 Steps should be wide enough to allow people to negotiate them comfortably by holding onto one or both handrails or by being assisted.
- 5.26 The width of the steps should reflect the amount of pedestrian traffic.
- 5.27 A minimum unobstructed, clear stair width between handrails of 1000 mm for one person, or 1500 mm for two-way traffic, is necessary. The minimum 1000 mm wide channel ensures that people can use both handrails if they wish.
- 5.28 [Figure 24](#) illustrates an example design of internal stairs for healthcare buildings.

Lighting

- 5.29 Stairs and landings should be well illuminated; see the latest version of LG2 for detailed guidance on lighting.

- 5.30 The lighting should be designed so that it highlights the differences between risers and treads, the top and bottom steps, and any changes in direction.
- 5.31 Lighting that causes glare (for example poorly located spotlights, floodlights or low-level light sources) should be avoided.

Ramps

- 5.32 Ramps may be provided in place of steps in some situations, in particular to facilitate egress of wheelchair users or those with pushchairs in an emergency, and should be provided to bypass all short flights of steps. (See [Approved Document M \(2013\)](#) and [BS 8300:2009+A1:2010](#) for detailed guidance on ramps.)
- 5.33 However, ramps are generally not considered appropriate for any significant changes in internal level within a healthcare building.

Mattress evacuation

- 5.34 [Figure 25](#) illustrates an example staircase design for mattress evacuation. [Table 1](#) provides optional/alternative dimensions for the clear width of stairs and landings. Dimensions in [Table 1](#) are supported by [Figure A3 in Appendix 4](#).
- 5.35 For mattress evacuation, the number of turning manoeuvres in descending a staircase should be as few as possible.
- 5.36 See [Health Technical Memorandum 05-02](#) for further details of staircase design for mattress evacuation.

Figure 24 Internal stairs

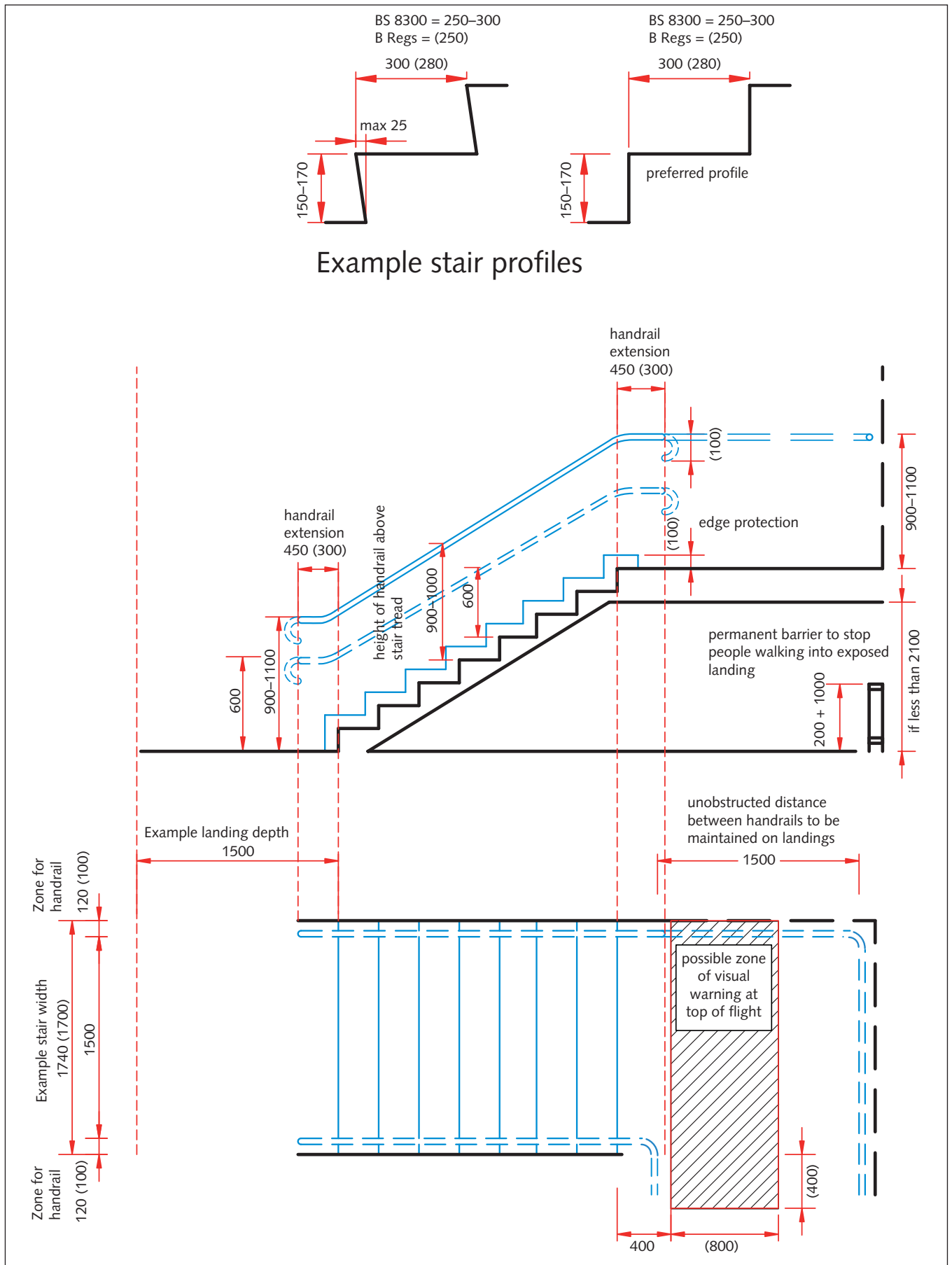

Table 1 Alternative stair and landing dimensions to facilitate mattress evacuation

A Minimum clear landing width	B Minimum clear stair width	C Minimum clear landing depth	
2800	1100	1950	allows mattress evacuation only
2800	1200	1925	
2800	1300	1850	allows mattress evacuation and restricted ambulant passing
3000	1400	1750	
3220	1500	1550	
3400	1600	1600*	allows mattress evacuation plus ambulant passing
3800	1800	1800*	

* Stair width is not determined by the number of people expected to use the stairs in a fire emergency, but principally by the requirements of mattress manoeuvrability.

For a clear landing width of 3400 mm, the minimum clear landing depth for mattress evacuation is 1450 mm. 1600 mm is recommended to enable ambulant passing and to equal the clear stair width. See BS 8300.

For a clear landing width of 3800 mm, the minimum clear landing depth for mattress evacuation is 1350 mm. 1800 mm is recommended to equal the clear stair width. See BS 8300.

Figure 25 Mattress evacuation down stairway

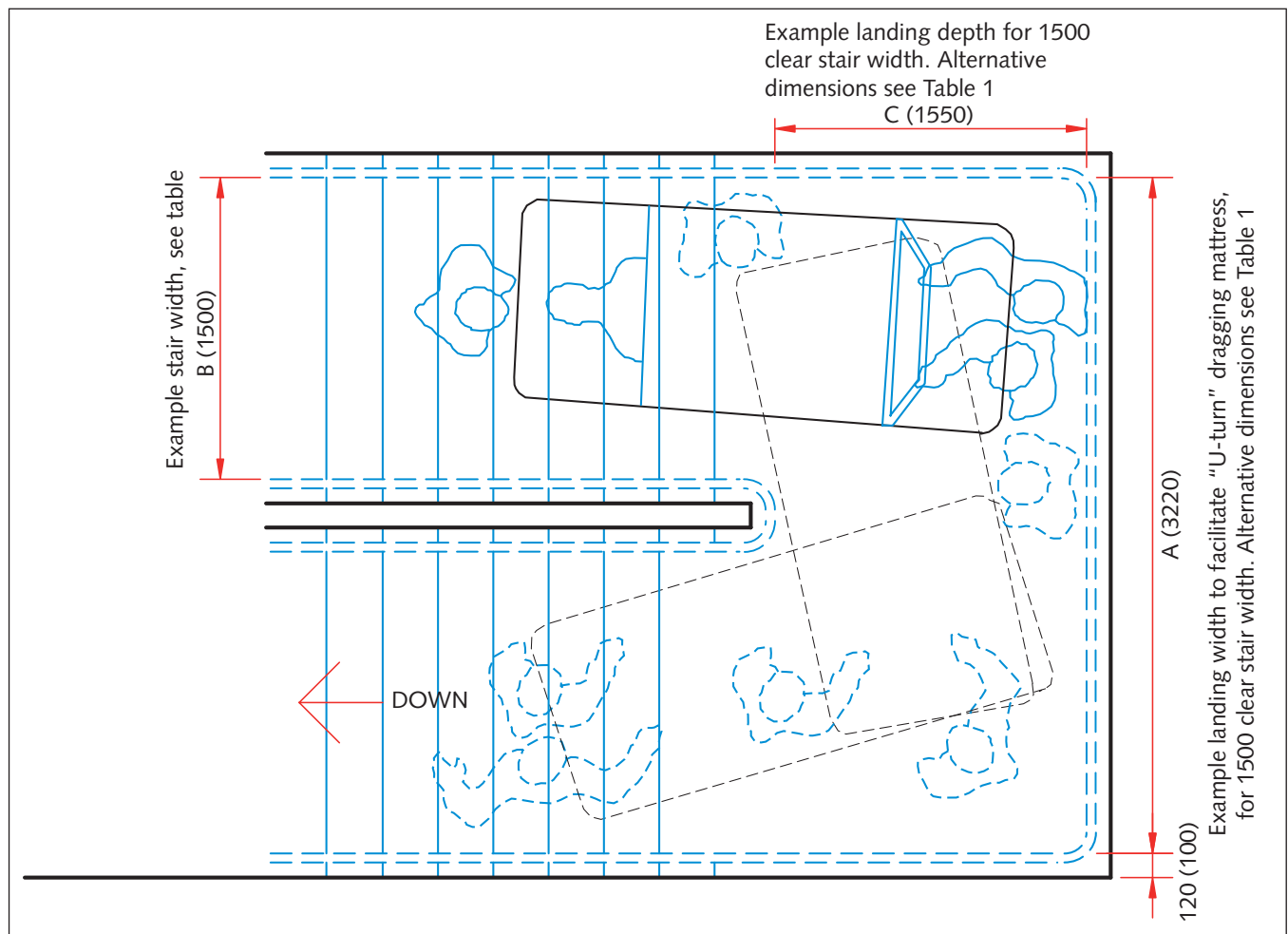

6 Lifts

Introduction

- 6.1 This chapter provides guidance on the design of lifts for general traffic, patient trolleys/stretchers and beds.
- 6.2 It does not cover goods traffic lifts.
- 6.3 The following guidance is for planning purposes only. For detailed technical information see:
- Health Technical Memorandum 00 – ‘Policies and principles of healthcare engineering’;
 - Health Technical Memorandum 05-03 Part E – ‘Escape lifts in healthcare premises’;
 - BS 8300:2009+A1:2010/Approved Document M (2013) for information on landing indicators, landing calls, lift car controls and emergency communication etc in relation to disabled access;
 - BS 5655-6:2011;
 - CIBSE Guide D;
 - BS EN 81-70:2003.

Selection of lifts

- 6.4 Lifts should be versatile to accommodate as many types of load as possible.
- 6.5 The number, type, size and speed of lifts should be determined from a traffic analysis specific to the proposed building development, and should allow adequate flexibility of the lift solution to accommodate future changes.
- 6.6 At least one wheelchair-accessible lift should be in operation between each floor of a healthcare facility.
- 6.7 Where planning allows, lift cars may be provided with doors on opposing sides to allow wheelchair users to exit without reversing out.

Lift size

- 6.8 All lifts in healthcare buildings should have minimum internal dimensions of 1100 mm (wide) × 1400 mm (deep); that is, be capable of accommodating at least eight people (or 630 kg).

General traffic lifts

- 6.9 General traffic lifts should have minimum internal dimensions of 1600 mm (wide) × 1400 mm (deep). See [Figure 26](#).
- 6.10 Handrails should be provided on both the side and rear walls of lift cars for general traffic. See [Chapter 7](#) for further details on handrails.
- 6.11 Consideration should be given to the provision of larger general traffic lifts, of 2000 mm (wide) × 1400 mm (deep). This size can accommodate any type of wheelchair together with wheelchair attendants and other passengers.

Lifts for trolley/stretcher movement

- 6.12 The recommended minimum lift size for patient trolley/stretcher movement is 1400 mm × 2400 mm (this will accommodate trolleys up to 800 mm × 2375 mm). See [Figure 27](#).
- 6.13 A lift of this size will just accommodate an extended standard hospital bed (1000–1050 mm × 2370 mm). However, it is not recommended for moving patients in beds.
- 6.14 Where trolley/stretcher lifts are to be used for general traffic, the lift car will require handrails (see paragraph 6.10); the internal dimensions of the lift (that is, 1400 mm × 2400 mm) will need to be clear of handrails.
- 6.15 Where provided, handrails should be limited to one sidewall of the lift car to minimise the potential risk to patients on trolleys; while patient trolleys may fit underneath side handrails, the rail overhang may inconvenience or pose a hazard risk to a patient on a trolley.

Lifts for bed movement

- 6.16 The recommended minimum lift size for the movement of patients on beds is 1800 mm × 2700 mm.
- 6.17 In order to segregate traffic, for operational and infection control reasons, it is not anticipated that lifts for bed movement will be used for general traffic.
- 6.18 Where bed lifts are also to be used for general traffic, the lift car will require handrails (see paragraphs 6.10 and 6.15). See Figure 28.

Lift landings and lobbies

- 6.19 Each lift should open onto a landing of adequate depth, in order not to restrict traffic flow in front of the lift entrance, or onto a protected lobby. Lifts should not open directly onto corridors.
- 6.20 A protected lobby should be provided where a lift does not open off a hospital street (see paragraphs 6.25–6.27 of Health Technical Memorandum 05-02 for details). See also Health Technical Memorandum 08-02 – ‘Lifts’ for details of current best practice.
- 6.21 Figures 26–28 illustrate the minimum space requirements outside lifts.
- 6.22 The lift landing/lobby walls and lift door should contrast visually, as should the landing floor and lift floor.
- 6.23 Additionally, a visually contrasting floor surface measuring at least 1500 mm × 1500 mm should be provided outside the lift door area. See the latest version of LG2 for detailed guidance on lighting.

Lift finishes

- 6.24 The lift car should be fitted with a slip-resistant floor covering with similar frictional qualities to the floor of the lift landing.
- 6.25 The floor covering should provide good grip but minimum resistance to the movement of wheelchairs and wheeled trolleys (studded flooring is not recommended).
- 6.26 The floor should have a high luminance to reassure people that they are not stepping into an open lift shaft.
- 6.27 Mirrors and reflective glass should be avoided in lifts, as they can cause confusion and disorientation.

Lighting

- 6.28 Wall-wash lighting, uplighting or perimeter lighting rather than direct downlighting should be used in bed and trolley/stretcher lifts to avoid dazzling patients being transported.

Doors

- 6.29 Lift doors for general traffic lifts should provide a clear opening width of 1100 mm and height of 2000 mm (see BS ISO 4190-1:1999).
- 6.30 Lift doors for movement of patient trolleys/ stretchers and beds should provide a minimum clear opening width of 1370 mm and height of 2100 mm.

Figure 26 General traffic lift

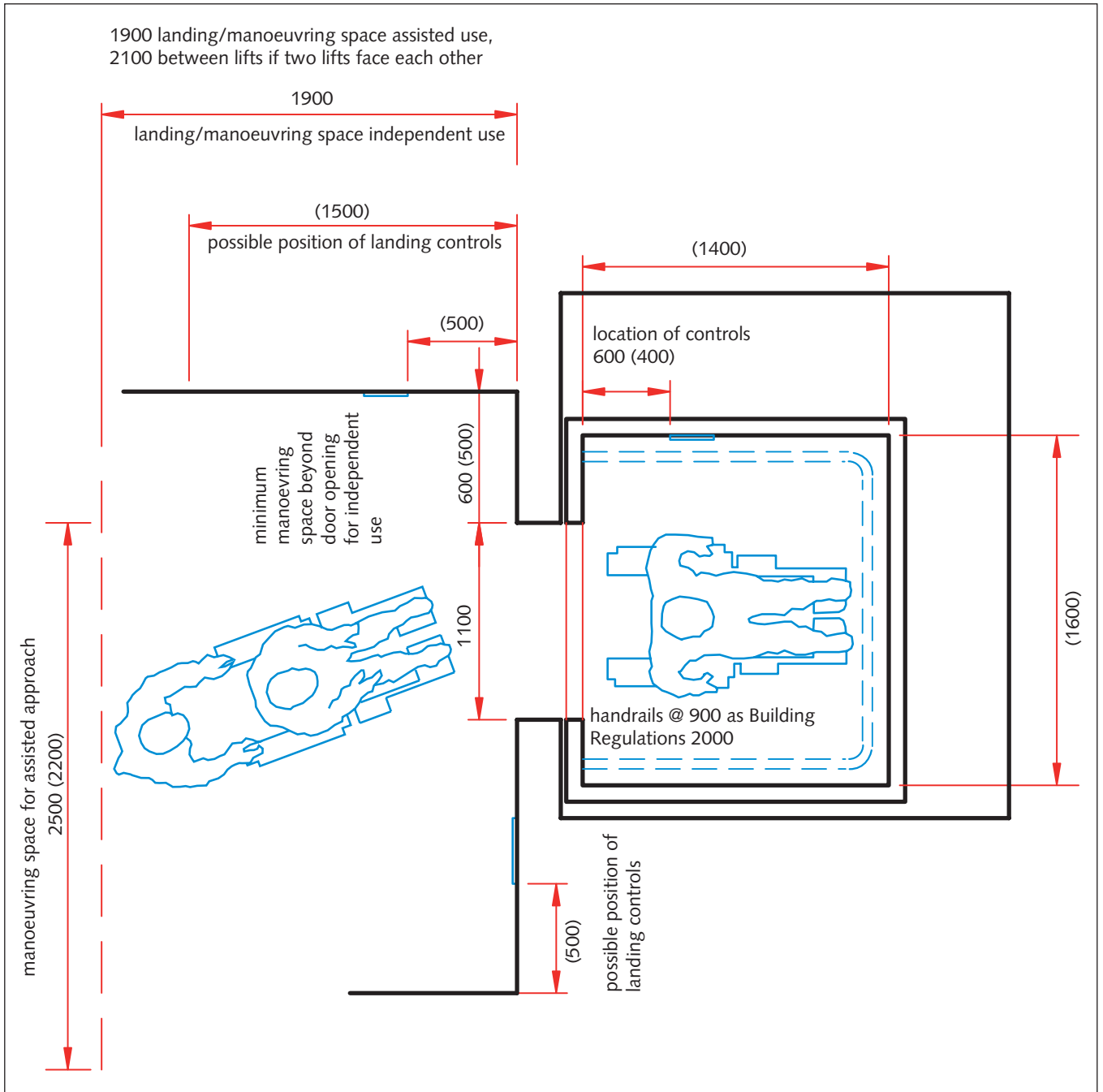

Figure 27 Lift for trolley/stretcher movement

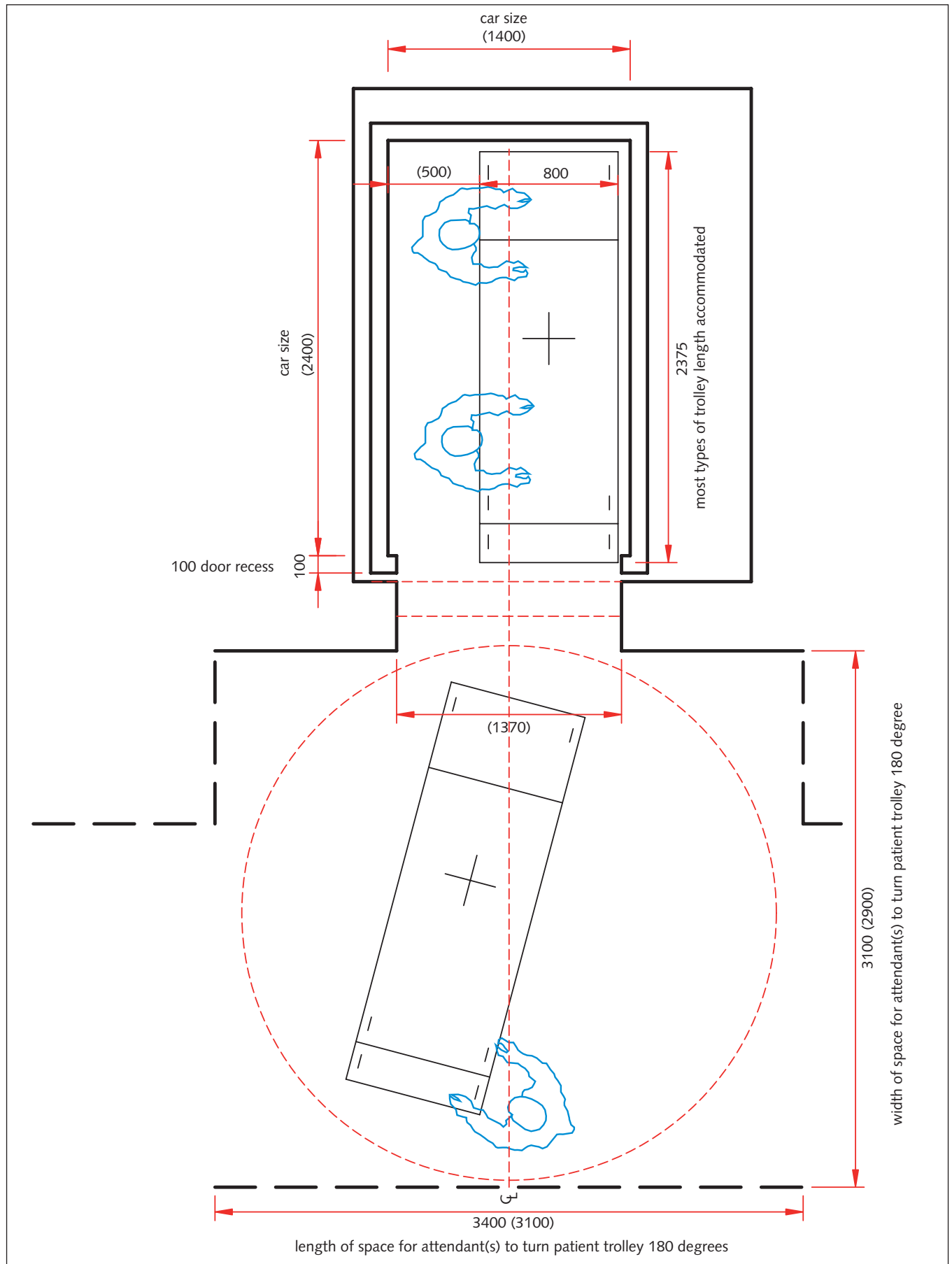
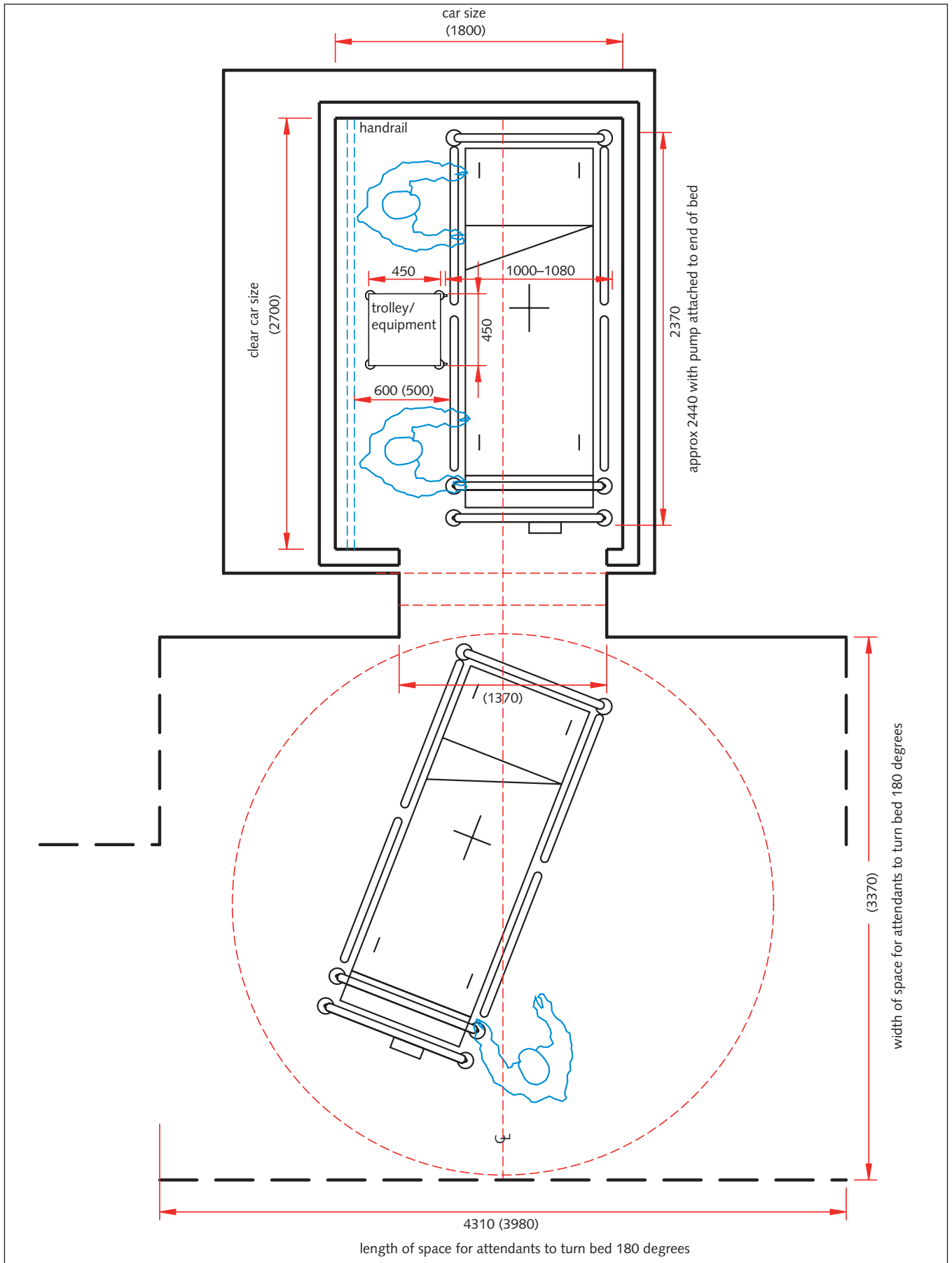

Figure 28 Lift for bed movement



7 Handrails

Introduction

- 7.1 This chapter provides guidance on the design of handrails in circulation and communication spaces. See also [paragraphs 3.29–3.31](#).
- 7.2 Where handrails and wall protectors are required, they may be combined or kept separate (see [paragraph 7.20](#)). For further details on wall protection see Health Building Note 00-10 Part B: ‘Walls and ceilings’.

Shape and size

- 7.3 Handrails should be easy to grasp; the size and shape should allow a firm but comfortable grip with the whole hand.
- 7.4 Handrails that are too small are uncomfortable and provide an unsatisfactory grip, whereas handrails that are too large are difficult to grip for people with weak or arthritic hands.
- 7.5 A handrail that is round in cross-section with a diameter of 40–45 mm (differing from Approved Document M requirement of 32–50 mm) is recommended. Oval handrails with dimensions of 38 mm × 50 mm wide (that is, 1mm narrower than the 39 mm required by Approved Document M) are acceptable. In both cases, the longer dimension should be horizontal.
- 7.6 Handrails with a large square or rectangular cross-section should be avoided.

Clearance

- 7.7 Handrails should allow enough space between the rail and the adjacent wall (or any other obstacle) for hands to pass without scraping knuckles and to aid those who want to use the rail as a support for the whole forearm.
- 7.8 A clearance of 60–75 mm (10 mm less than Approved Document M states) is recommended, as this allows the forearm to be rested on the rail without any danger of it getting trapped.

- 7.9 Recessed handrails are not recommended, as they cannot be leant on for support.

Height

- 7.10 The top of the handrail should be:
- 900–1000 mm above the surface of a ramp, ramp landing or pitch line of a flight of steps or along a corridor;
 - 900–1100 mm from the surface of a stair landing.
- 7.11 A second lower rail at a height of 600 mm should be provided in corridors, stairs and landings in children’s healthcare facilities and on ramps (for wheelchair users). They should also be provided on stairs and landings in healthcare premises where there are likely to be a significant number of semi-ambulant users.

Withstandable force

- 7.12 Handrails should be rigid, securely fixed and able to support the weight of a person leaning on them.
- 7.13 They should be sufficiently secure to support a person grasping them to prevent or arrest a fall:
- vertically, they should support 95% of people plus a margin of 50% (that is, 88 kg + 44 kg) = 132 kg;
 - horizontally, they should support a force from an adult of 155 N + 50% = 233 N.

Provision on stairs, ramps and landings

- 7.14 Continuous handrails on stairways, ramps and landings help people to negotiate changes in direction.
- 7.15 Vertical handrail risers or interruptions of handrails to accommodate newel posts and supports should be avoided.
- 7.16 Handrails should extend horizontally for 300 mm past each end of the change in level and, where they

do not interrupt pedestrian routes, an extension of 450 mm is recommended.

- 7.17 They should return to a wall or at least 100 mm down towards the floor, and should terminate in a way that reduces the risk of clothing being caught.
- 7.18 Handrails on ramps may be provided on low walls (see Figure 29), but the handrail must not be located more than 50 mm back from the edge of the ramp.

Provision in corridors

- 7.19 Handrails should return into recessed doorways and openings, but otherwise be continuous to aid navigation.

Handrails in association with wall protection

- 7.20 Where handrails and wall protectors are provided:
- a minimum vertical clearance of 50 mm must be maintained between the handrail and wall protector (see Figures 30 and 31);
 - where the wall protector protrudes in front of the handrail, the clear width of the corridor will be to the wall protector (see Figure 31).

Balustrades

- 7.21 Balustrades should be provided around landings at a height of 1100 mm above the floor. The space between the balusters should be no wider than 100 mm. They should not provide toeholds for climbing.

Appearance/finishes

- 7.22 Handrails should be:
- easily visible, that is, contrast visually with the surface to which they are fixed;
 - smooth and free of any abrasive elements;
 - neither too cold nor too hot to the touch.
- 7.23 Handrails may have raised indicators built in to convey information such as floor level.

Figure 29 Handrail on low wall, suitable for ramped access

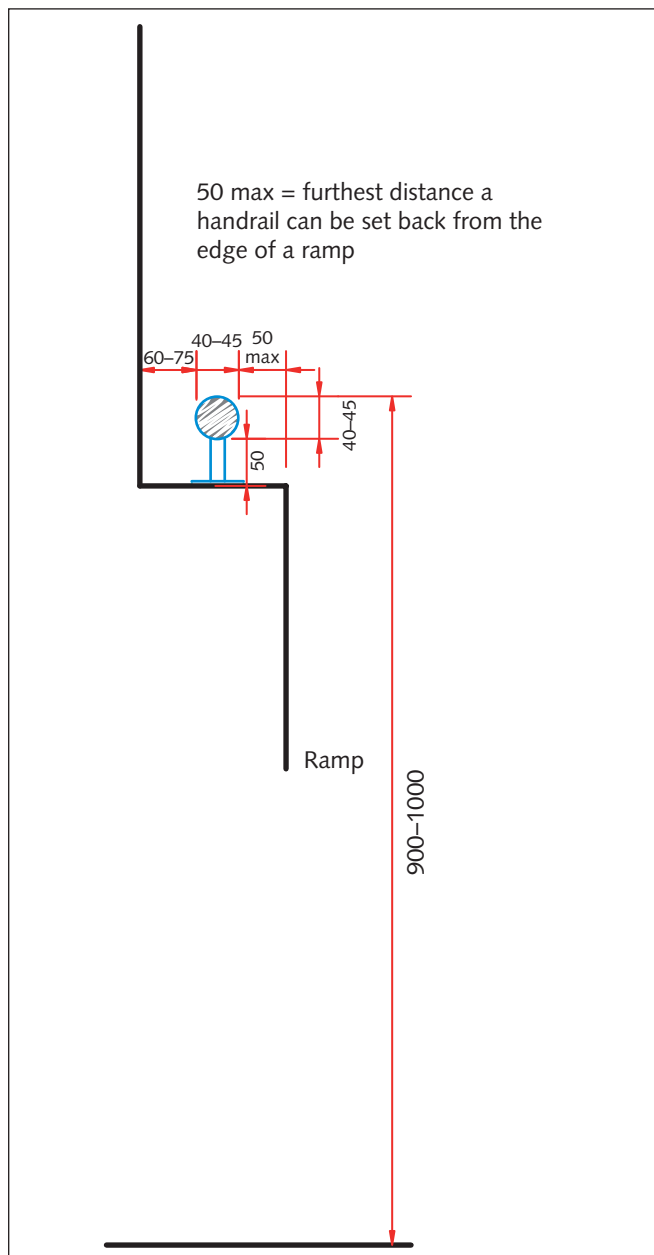

Figure 30 Handrails and separate wall protection

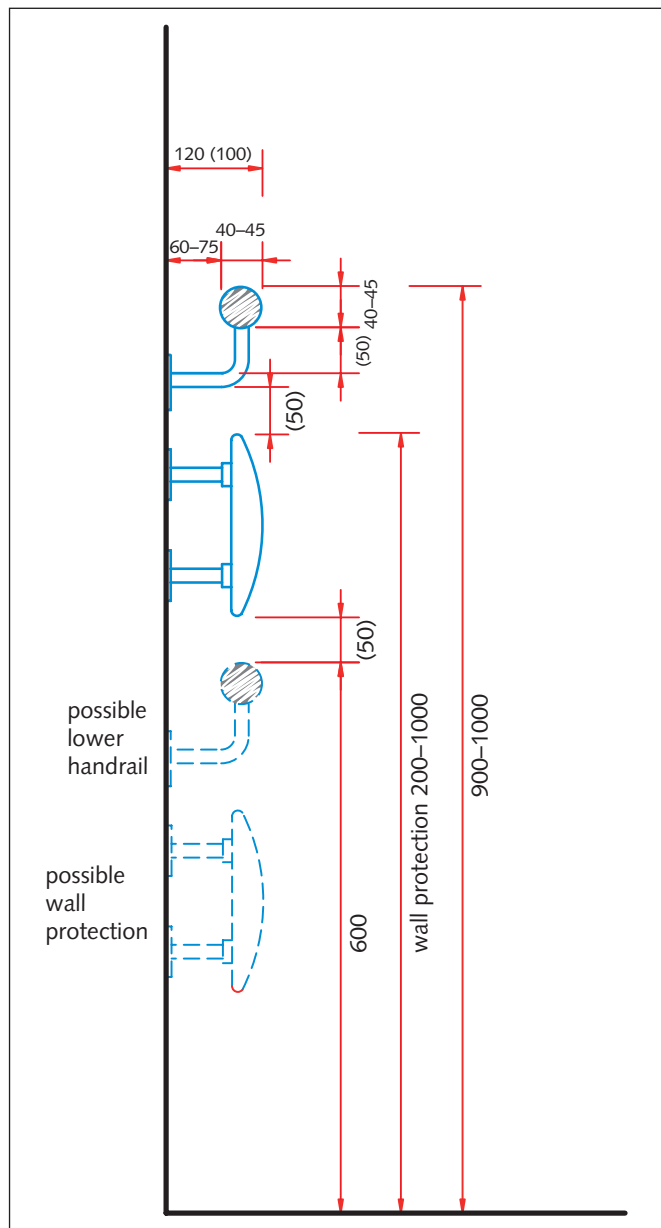
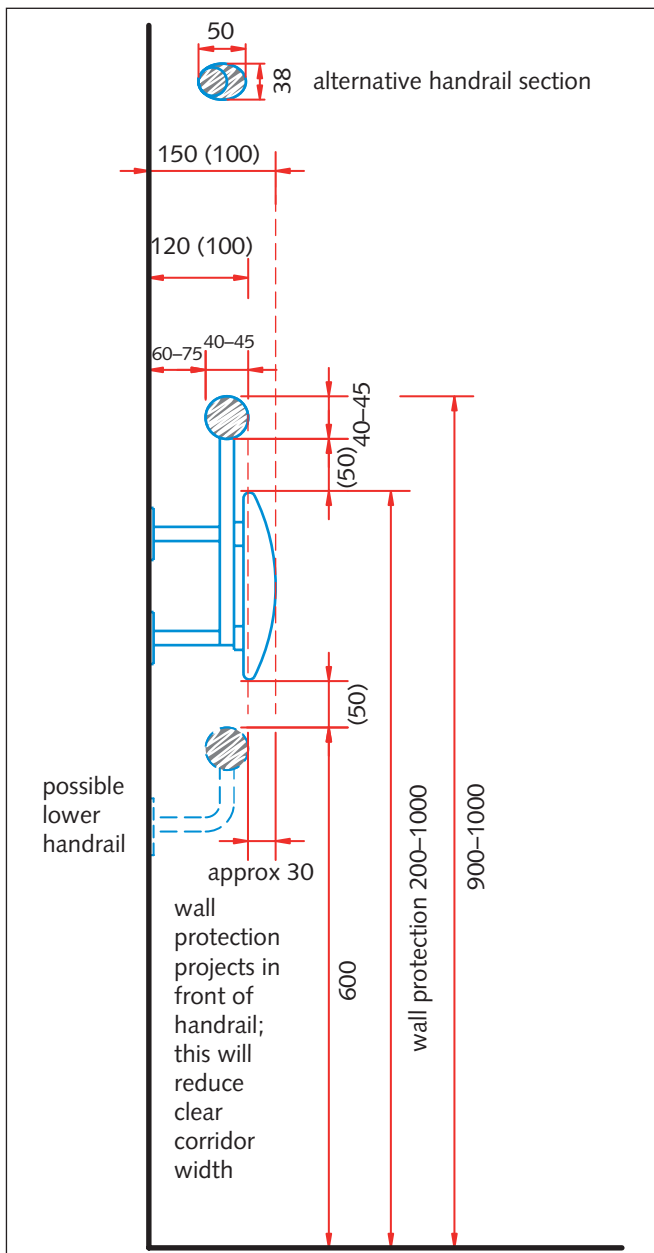

Figure 31 Handrails and combined wall protection



8 Doors

Introduction

- 8.1 This chapter provides guidance on the design of internal doorsets in circulation and communication spaces.
- 8.2 See Health Building Note 00-01 – ‘General design principles’ for guidance on doors and frames.

Approach

- 8.3 A level area is required in front of doors to allow people to stand/park a wheelchair/pushchair whilst manoeuvring the door.
- 8.4 Generally, doors should open away from areas with high traffic flow towards areas with a lower traffic flow. However, this will be influenced by the requirements of means of escape (see [paragraph 3.4](#)).
- 8.5 Clear space should be provided at the latch side of each door to provide access to the door handle and allow a person to wait whilst someone comes through the door in the opposite direction.
- 8.6 Where there is high usage it will be necessary to provide a waiting space on both sides of the door.
- 8.7 The following clear spaces should be provided:
 - 600 (450) mm to the latch side of the door, when the door opens towards a person using it;
 - 450 (300) mm to the latch side of the door, when the door opens away from a person using it;
 - 600 (450) mm to the latch side, on both sides of the door, where doors swing in both directions.
- 8.8 Doors in the corner of spaces/rooms should be hung with the hinges nearest to the corner of the room so that the door rests alongside the wall when open. This assists people with wheelchairs/pushchairs and/or mobility difficulties to manoeuvre effectively and pass through the door.

Threshold

- 8.9 A step or threshold should be avoided at doorways.
- 8.10 Where a threshold is unavoidable on internal doors (for example doors with acoustic seals), its maximum height should be 10–13 mm.
- 8.11 A threshold in excess of 5 mm should be chamfered or rounded.
- 8.12 Rubber thresholds are the most easily traversed by wheelchairs and pushchairs.

Door opening width

- 8.13 The key issue with regard to access through a door is the effective clear opening width (ecw) of the door(s) rather than the doorset size.
- 8.14 The ecw for a swing door is the available width measured at 90 degrees to the plane of the doorway clear of all obstructions (such as protruding ironmongery) when the door is opened through 90 degrees or more. See Approved Document M (2013), Diagram 9.
- 8.15 The ability of the door to open through greater than 90 degrees will depend upon the size of the door nib and the extent of any protruding ironmongery.

Note

The door nib is the length of wall between the edge of the structural door opening and a wall running, generally, perpendicular to the one incorporating the door. See [Figures 32–36](#).

Single doors

- 8.16 For internal single doors, an ecw of 850 mm (minimum 800 mm) is generally recommended. This can be achieved with a standard 1000 mm doorset where the door can open beyond 90 degrees (see [Figure 32](#)). This will allow:
 - general traffic access;

- limited hoist access including standing/raising aide.

Note

Standing/raising aide is a type of hoist used where patient has weight-bearing capability in their legs. See website www.arjo.com/int/Products.asp?PageNumber=243&ProductCategory_Id=13

- 8.17 The use of a sling hoist with legs closed or multipurpose hygiene chair will require a minimum clear corridor width of 1350 mm (see [Figure 32](#)).

Leaf and a half doors

- 8.18 With a leaf and a half door, the leaves are divided asymmetrically.
- 8.19 Suitable access will be possible when the following conditions are met:
- for general traffic access, the larger of the two doors must provide an ecw of 850 mm (minimum 800 mm subject to minimum clear approach space of 1500 mm) when only the larger leaf is open. This can be achieved with a 1300 mm doorset (see [Figure 33](#));
 - for hoist access (including shower trolleys and sling hoists with legs open and two attendants), an ecw of 1150 mm (minimum 1050 mm) is recommended when both leaves are open. The minimum ecw can be achieved with a 1300 mm doorset (see [Figure 33](#)). However, a 1500 mm doorset is recommended as this provides the recommended ecw without opening the doors significantly beyond 90 degrees (see [Figure 34](#));
 - for bed access when turning 90 degrees from a corridor into a room, with four attendants passing through the door with the bed (two at the front and two at the back), an ecw of 1550 mm is recommended when both leaves are open and the clear corridor width is between 2150 and 2400 mm. The ecw of 1550 mm may be achieved with a standard 1700 mm doorset with at least one door leaf opening significantly greater than 90 degrees (see [Figure 16](#));
 - for bed access when turning 90 degrees from a corridor into a room with a recessed door, with four attendants passing through the door with the bed (two at the front and two at the back), an ecw of 1370 mm is recommended when both

leaves are open and the clear corridor width is a minimum of 2900 mm opposite the door. The ecw of 1370 mm may be achieved with a standard 1700 mm doorset with the doors opening just greater than 90 degrees (see [Figures 17 and 35](#));

- for bed access when turning 90 degrees from a corridor into a room with a recessed door, with two attendants passing through the door with the bed (one at the front and one at the back), a minimum ecw of 1200 mm is considered acceptable when both leaves are open and the clear corridor width is a minimum of 2900 mm opposite the door (see [Figure 17](#)). The ecw of 1200 mm may be achieved with a 1500 mm doorset with standard ironmongery when the door leaves opens beyond 90 degrees (see [Figure 34](#)).

Note

The recommended ecws for bed access are based on the assumption that bed-mounted equipment will not project significantly beyond the bed width of 1000–1080 mm (see [paragraph 1.16](#)). Where mobile equipment needs to be moved with the bed and/or larger beds are to be used, a risk assessment should be carried out on the space requirements for access. See [Appendix 1](#).

- 8.20 To avoid confusion, wherever an asymmetrical door arrangement occurs, if possible, the handing of asymmetrical doors should be consistent throughout the building.

Double doors

- 8.21 Suitable access will be possible when the following conditions are met:
- for general traffic access, in heavily trafficked areas, it is recommended that both leaves provide an ecw of 850 mm (minimum 800 mm) when only one leaf is open. This can be achieved with a 1900 mm doorset (see [Figure 36](#));
 - for beds access, heavily trafficked areas, a minimum ecw of 1740 mm is recommended when both leaves are open. This can be achieved with a standard 1900 mm doorset (see [Figure 36](#)).

Figure 32 1000 mm single doorset

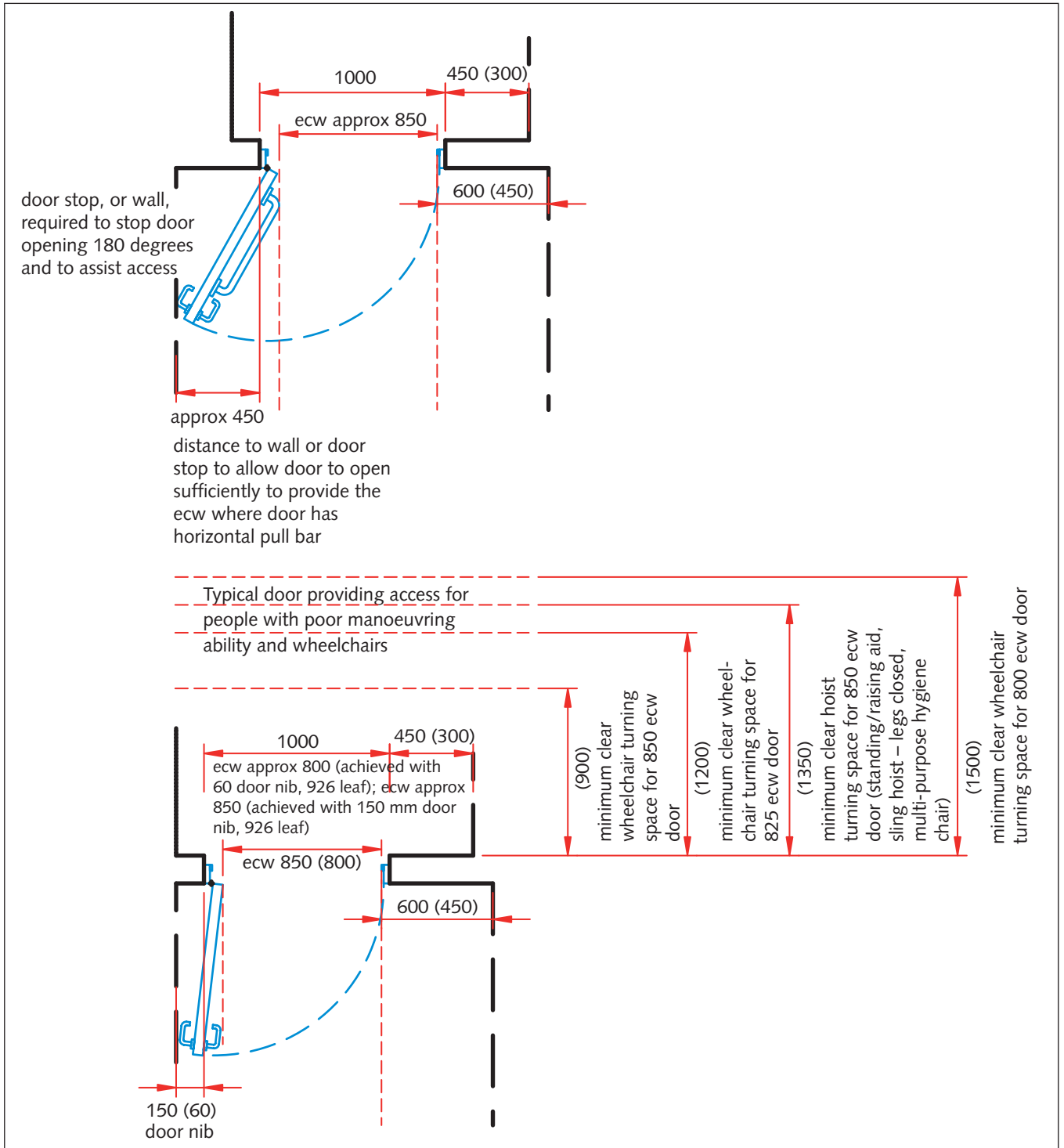

Figure 33 1300 mm leaf & half doorset

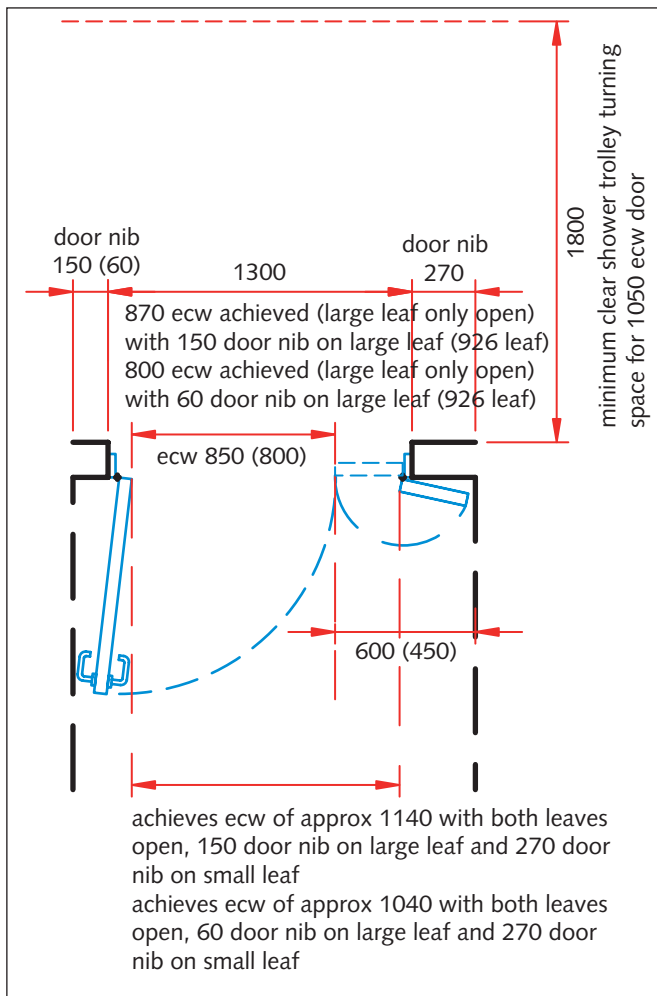

Figure 34 1500 mm leaf & half doorset

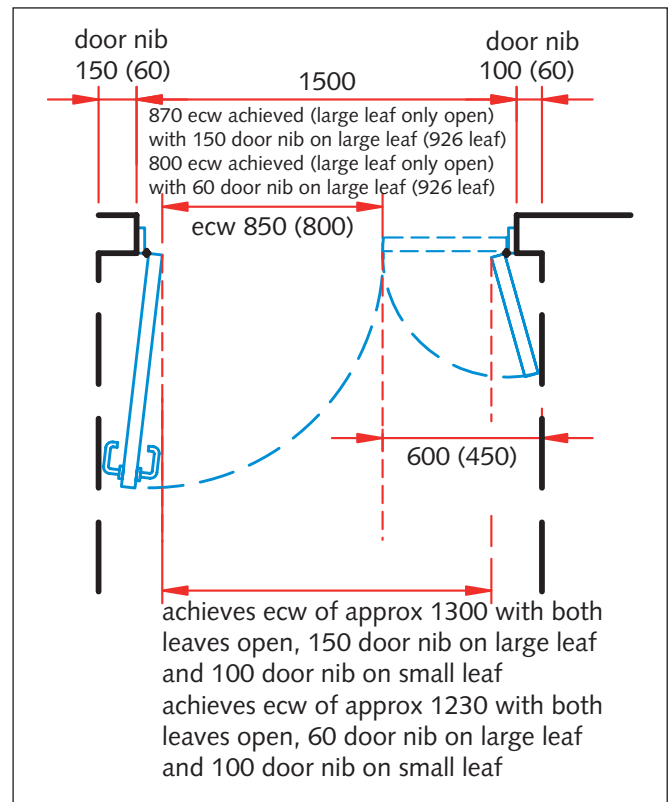

Figure 35 1700 mm leaf & half doorset

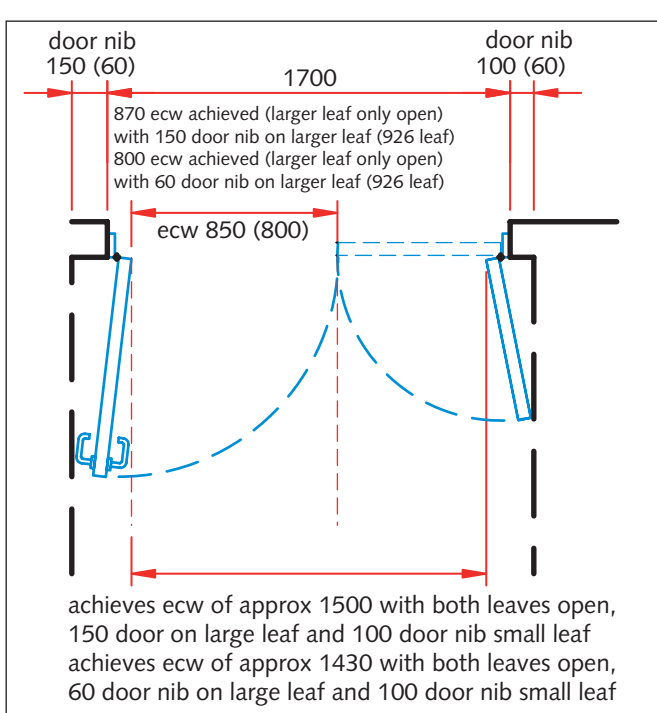
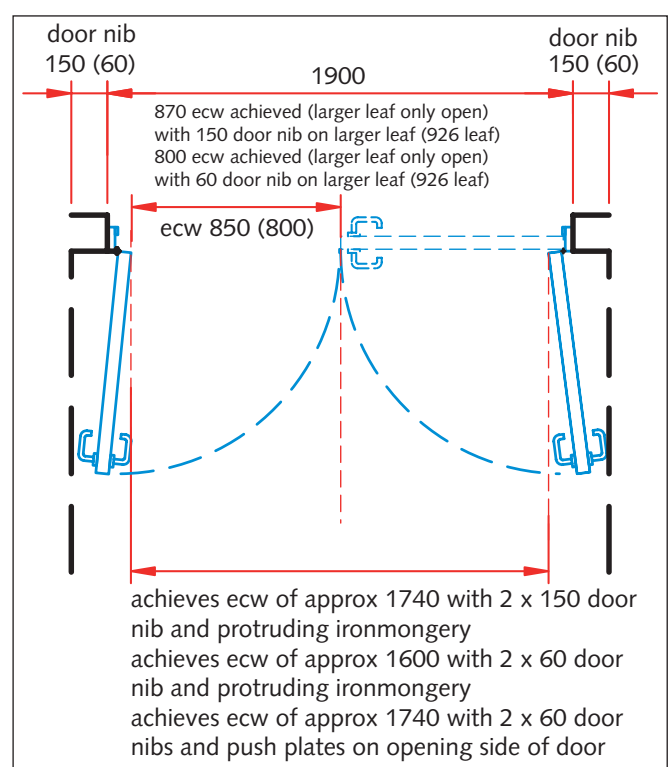

Figure 36 1900 mm double doorset



Force to open door/door closers

- 8.22 The force required to push or pull doors should be kept to a minimum.
- 8.23 Door closers should meet the requirements of both Approved Document B and Approved Document M, as appropriate. See BS 8300 and Approved Document M in relation to door closers.
- 8.24 Automatic closers on double swing doors should have a check mechanism to prevent them swinging beyond the closed position.
- 8.25 Strong floor spring closers (often fitted to external heavy doors) should be avoided unless used in conjunction with automatic opening and closing devices.

Fire doors

- 8.26 Fire doors fitted with door closers are heavy and awkward to open and hamper easy circulation. Fire doors on circulation routes, and those not needing to be closed for security reasons, should be fitted with electromagnetic stays or swingfree door closers, which will close in the event of a fire alarm.
- 8.27 On doors that are designed to remain open, the edges should be recessed when open in order to avoid creating an obstruction. Alternatively, the edges should contrast visually with the background against which they will be viewed.

Door handles

- 8.28 Door handles should be easy to use. Their section should be circular or similar (see Figure 17 in BS 8300).
- 8.29 Door handles should allow a firm grip for the hand, and be fixed at a height of 900–1100 mm, preferably 1000 mm (see Figure 37).
- 8.30 Consistent positioning will allow people to find the handle more easily.

Pull handles

- 8.31 Knobs and round pull handles should be avoided, since people with impaired hand function find these difficult (if not impossible) to use.
- 8.32 Pull handles should be D-shaped to reduce the risk of catching clothing or causing injury.

- 8.33 Doors to be closed by wheelchair users without assistance should be fitted, along the width of the closing side of the door, with a horizontal pull bar handle. The handle should be mounted at a height of 900–1100 mm, preferably 1000 mm (see Figure 37).
- 8.34 Horizontal bars reduce the ecw of the door, and this must be considered when selecting the doorset (see Figure 32).
- 8.35 Vertical pull handles enable people of different heights to grasp them at a height that gives them the best mechanical advantage, enabling doors to be opened more easily (see Figure 37).

Handles for latching doors

- 8.36 Door handles that unlatch should be easy to grasp and open with one hand.
- 8.37 Lever handles are recommended because they can be elbow-operated by a person with impaired hand function. The design of the lever handle should minimise the risk of catching clothing or causing injury, for example by curving the end of the lever towards the door.
- 8.38 Minimal force should be required to operate the lever.

Sliding doors

- 8.39 Sliding doors are economical in terms of space requirements.
- 8.40 Automatic sliding doors are easy to use.
- 8.41 Heavy sliding doors must be automatically controlled.
- 8.42 Automatic sliding doors should allow manual operation in the event of a power failure.
- 8.43 Sliding doors should:
 - allow for rapid evacuation;
 - be clearly marked to avoid confusion with conventional push/pull side-hung doors;
 - be well-maintained to ensure that the tracks allow smooth movement;
 - incorporate a safety device (that is, a guard), either along the length of the sliding sections or between the doors and walls.

Figure 37 Recommended zones for vision panels and location of ironmongery

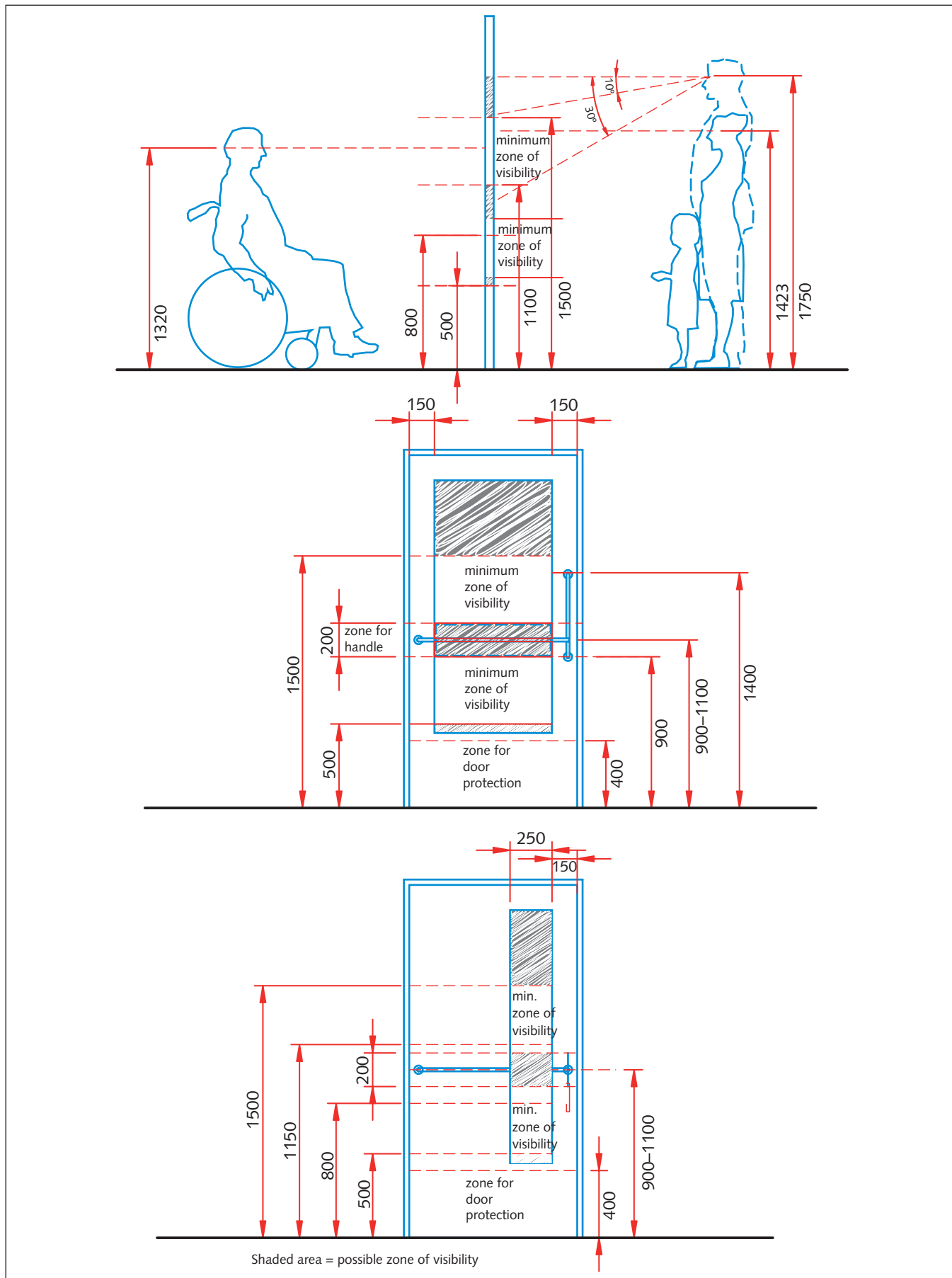

Automatic doors

- 8.44 The provision of automatic doors is recommended in areas of high use.
- 8.45 Automatic sliding doors are preferable to automatic swing doors, and should open automatically in the event of a power failure or the need for rapid evacuation of a building (see BS 7036:1996).
- 8.46 Automatic doors should be provided with suitable warnings. See [paragraph 4.13](#).
- 8.47 For automatic swing doors, it is desirable that the depth of the door swing, when fully open, and an additional 1570 mm is marked on the floor in contrasting colour/tone (see [paragraph 4.9](#)).
- 8.48 Automatic double sliding doors should have a minimum clear width of 1200 mm for wheelchair traffic and 1740 mm for bed/trolley traffic.
- 8.49 Automatic doors may be triggered by photoelectric sensors, pressure pads or push buttons.
- 8.50 Sensors should detect all users, including children and guide dogs, and the sensor should not allow the door to close if the doorway is not clear.
- 8.51 If floor sensors are used, they should be sensitive to uneven pressure, for example that exerted by people using crutches.
- 8.52 Push buttons to activate automatic doors should be sited clear of the fully open door swing, at a height of 750–1000 mm, should contrast visually with the surrounding background, and should measure approximately 50 mm by 50 mm.
- 8.53 The use of power-operated revolving doors requires careful consideration and a risk assessment. If a revolving door is used, an additional accessible side-hung door must be available for use, without the need to call for assistance (see BS 8300 and BS 7036-5 for details).

Glazing

- 8.54 Door glazing should be easily identifiable as such.
- 8.55 Frameless glass doors should be easily identifiable to prevent people colliding with them (see Approved Document M for details).

- 8.56 All doors in corridors on circulation routes, and any which swing in both directions, should contain a glazed portion to allow people to see others approaching from the opposite direction (see [Figure 37](#)).

Kick plates

- 8.57 Doors should be fitted with kick plates, which should be mounted to a minimum height of 400 mm to protect them from damage from pushchairs and wheelchairs.

Visual contrast

- 8.58 Door frames should contrast visually with the walls/surrounding surfaces.
- 8.59 See BS 8300 (paragraph 9.1.1) for guidance on the visual characteristics of doorsets to assist people with impaired vision.

Privacy curtains

- 8.60 Where staff need to enter and exit rooms whilst patients are being examined or treated, and it is not possible to avoid potential views into the room, for patient privacy and dignity, consideration should be given to the use of privacy curtains inside the doors.
- 8.61 Local infection control advice should be sought on the use of privacy curtains. Consideration should be given to the design of the privacy curtains and provision of a suitable cleaning regime.
- 8.62 If wipeable curtains are used, they must be regularly wiped, they should not become discoloured (particularly with fungal growth), and they will need to be replaced regularly. If linen curtains are used, they must be changed frequently.
- 8.63 [Figures 38–40](#) illustrate the minimum space required for a person to open, pass through and close different doors behind a privacy curtain. The precise required layout of a curtain track will depend upon the door size and room configuration.

Figure 38 Privacy curtain options for 1000 mm doorset

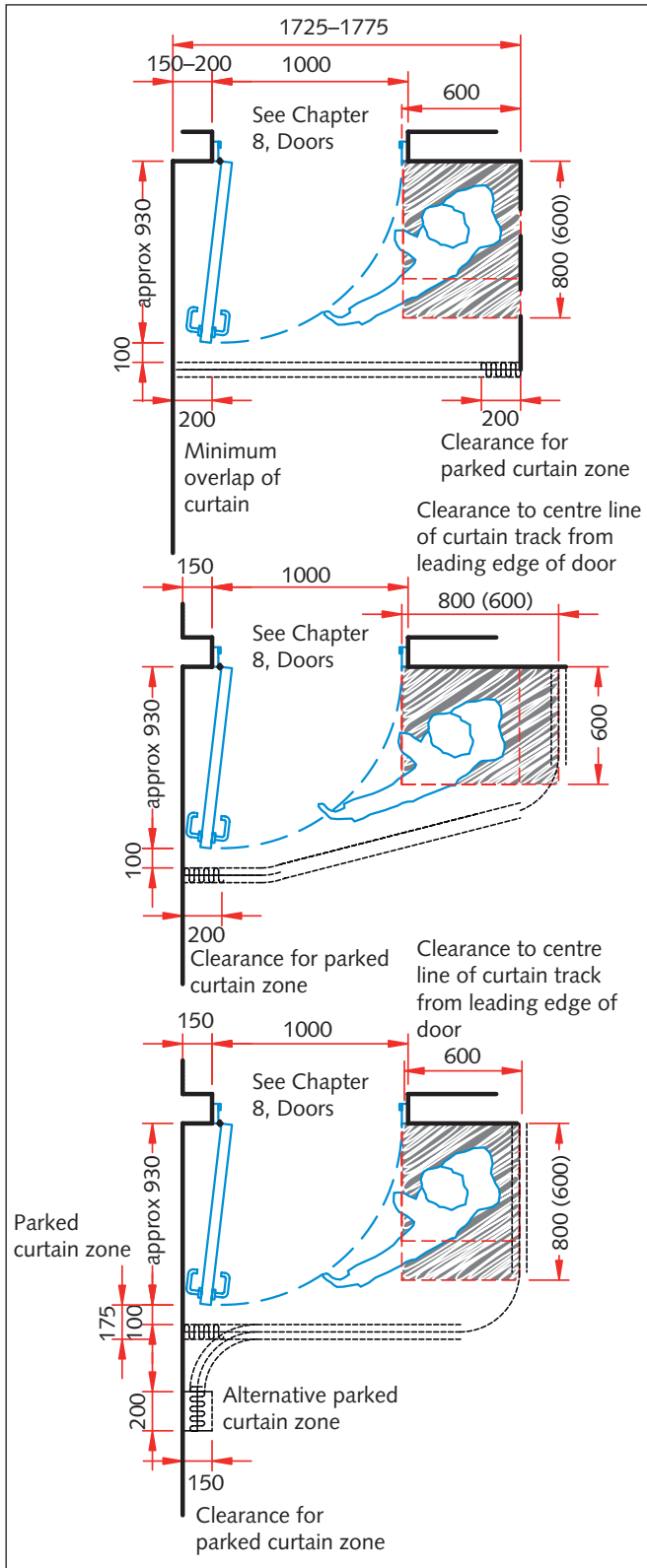
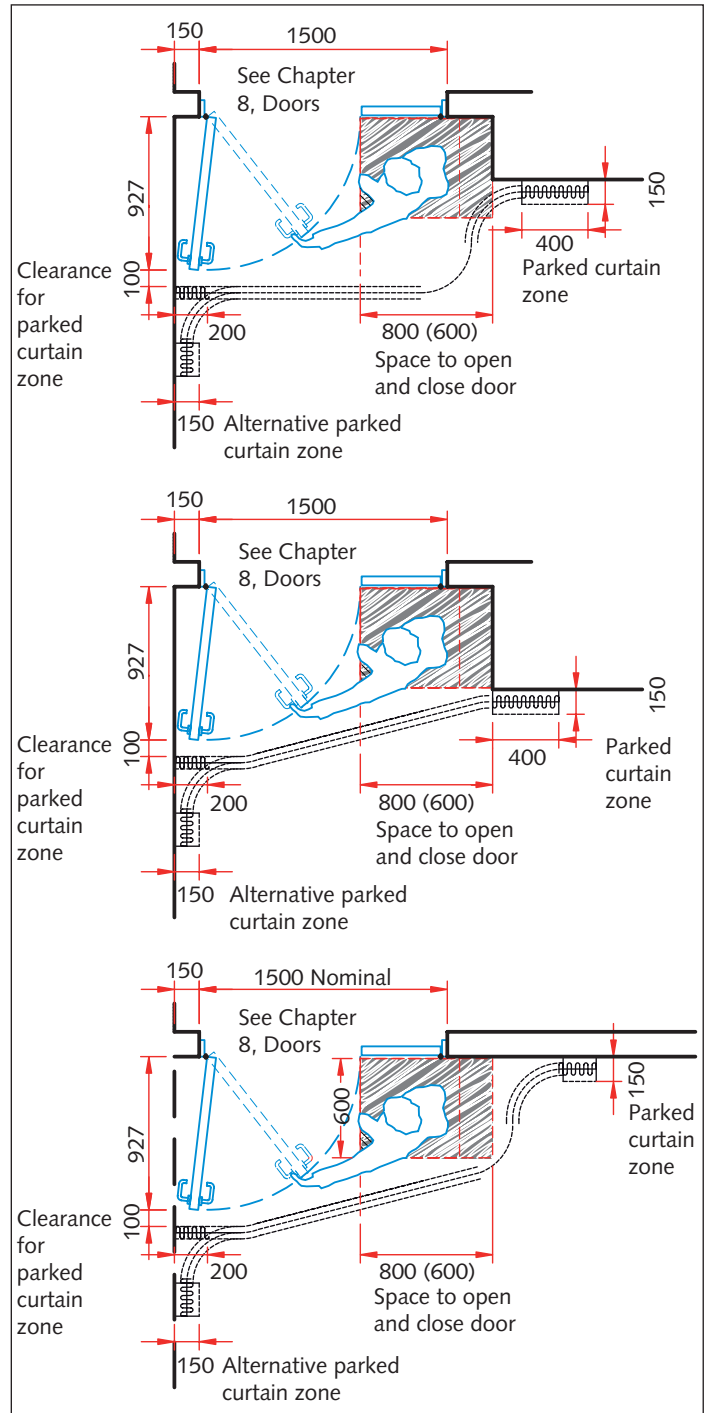
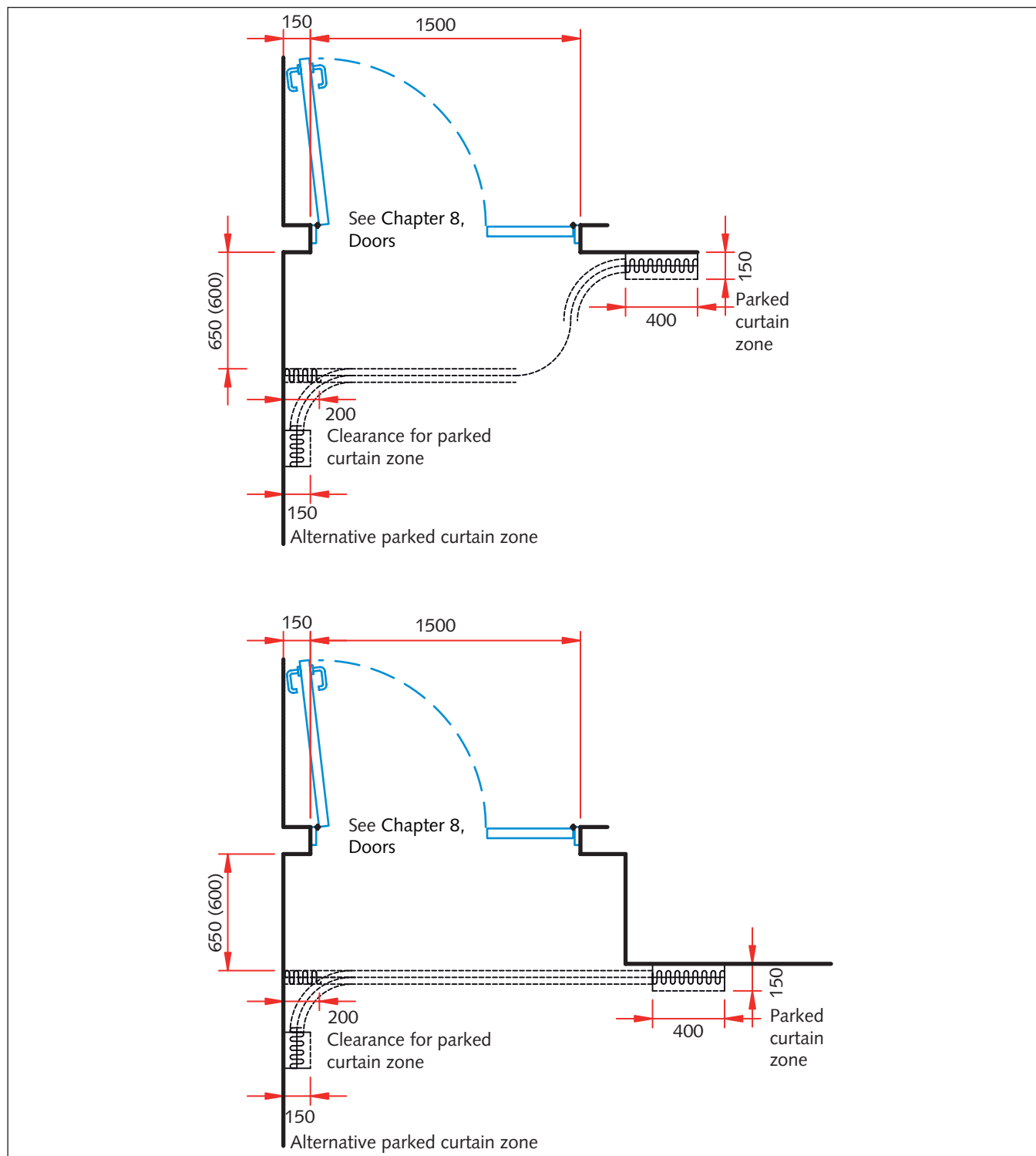

Figure 39 Privacy curtain options for 1500 mm doorset



Note: Shaded area = area required for someone to open and close the door behind the curtain

Figure 40 Privacy curtain options for 1500 mm outward opening doorset



Door signage

8.64 Signs on or adjacent to doors should be at a height of 800–1500 mm and tactile so that they can be easily read by touch. See 'Wayfinding: effective wayfinding and signing systems guidance for healthcare facilities' for further details.

Appendix 1 – Bed movement study

The bed movement study was conducted at Leicester General Hospital during 2005. The study investigated space requirements for movement of:

- a standard hospital bed, with or without orthopaedic or other attachments (2190 mm × 1050 mm, or 2370 mm × 1050 mm with bed extended) and;
- a bariatric bed for a 450 kg patient (2330 mm × 1080 mm).

The study was based on the following assumptions/qualifications:

- attendants grasp the bed frame at the foot and head when manoeuvring beds – even when there are orthopaedic attachments present;
- four attendants are frequently used to manoeuvre beds;
- when pushing beds along corridors, attendants are usually positioned at the side of the bed but move to the end when required, for example at pinch points;
- attendants generally do not have to stay at the side of the bed during movement unless “bagging” a patient (for example providing artificial respiration to a patient on a ventilator);
- orthopaedic attachments require a minimum height of 1950 mm to ensure clearance under door frames or door closer mechanisms where present.

The anthropometric dimensions and skill of the handlers who carried out the study were analysed/considered.

The recommendations for space requirements take into account that:

- all handlers carrying out the study were fairly skilled;
- people with deep trunks need more space when turning sideways, that is, facing the side of the bed, as when going through “pinch” points;
- tall people’s elbows stick out more when pushing and pulling on bed frames;
- those who are of “large” build, for example have broad shoulders, require more space as they walk alongside the bed.

The space requirements illustrated in [Figures 8–11, 16 and 17](#) and associated text generally represent the findings of the study. However, it should be noted that the minimum ecw of 1200 mm in [Figure 17](#) and noted in [paragraph 8.19](#) is an agreed acceptable DH minimum, based on the recorded data during the study and professional opinion, but was not recommended in the report associated with the study.

Appendix 2 – Variations from Approved Document M and BS 8300

Corridor widths for general traffic

Approved Document M requires a minimum unobstructed corridor width of 1200 mm, if passing spaces are provided. However, BS 8300 states a preferred clear corridor width of 1800 mm in buildings with a significant number of wheelchair users. Due to the nature of the users/visitors in healthcare premises (that is, increased semi-ambulant and wheelchair users) and having considered the space requirements for circulation, this guidance recommends a minimum unobstructed width of 1500 mm but recognises that 1800 mm will allow most users to pass comfortably.

Lobby length/size

BS 8300 allows for a reduction in lobby length if doors feature vision panels, on the basis that a sighted person would be able to see a user immediately in front of the door and not open the door into them. However, vision panels will not assist visually impaired people to negotiate a lobby and are therefore not used as an argument for reducing lobby length in healthcare premises.

Approved Document M allows for a reduction in lobby length of 100 mm for every 100 mm added to the lobby width. Research for this Health Building Note indicates there is no clear evidence to support this argument. This guide does not, therefore, recommend applying this argument to justify reducing lobby lengths in healthcare premises.

Internal stair tread

Approved Document M requires internal staircase tread goings to be a minimum of 250 mm whilst BS 8300 recommends 250–300 mm with a preference for 300 mm. This Health Building Note aligns closely with BS 8300 and recommends a minimum of 280 mm and a preference for 300 mm.

Internal stairs, number of risers in flights

Approved Document M states that “normally a flight between landings should contain no more than 12 risers”. However, the floor-to-floor height in many healthcare

premises is 4200 mm. Therefore, 14 risers are considered appropriate.

Visual warnings, change in level

Rising steps are readily detected by cane users, and the use of contrast nosings and handrails assists other visually impaired users; this Health Building Note therefore recommends that over and above recommendations in Approved Document M and BS 8300, for the safety of visually-impaired people a visual warning zone, using finishes that contrast visually with the surrounding floor, be applied at the top landing of all changes in level.

Approved Document M (2013) states: “Where a lift is provided, as a minimum a utility stair should be designed to be suitable for people with impaired sight. The lift should be suitable for an unaccompanied wheelchair user. Suitable provision should also be made for people with sensory impairments. Measures should also be adopted which give a disabled person sufficient time to enter the lift to reduce the risk of contact with closing doors.”

Lifts

Approved Document M and BS 8300 recommend a minimum lift car size of 1100 mm × 1400 mm for wheelchair access with a handrail fitted on the back wall of the lift car. However, both documents acknowledge that the minimum car size has access limitations. In healthcare premises, for flexibility of access, handrails are recommended on both side walls as well as the back wall. Additionally, to allow for more than one attendant with a wheelchair user, a minimum lift car size of 1600 mm × 1400 mm is recommended.

Handrails

The Department of Communities and Local Government (DCLG) has clarified its recommendations in relation to handrail sizes. In this clarification, the required cross-section size of circular handrails is 40–50 mm. However for healthcare premises, in accordance with (unpublished) research commissioned by the Department of Environment and carried out by Robert Feeny Associates, 40–45 mm is recommended.

The required clear space around handrails is 50–60 mm. However for healthcare premises, in accordance with research cited earlier, 60–75 mm is recommended.

Door access space

Approved Document M defines the minimum clear width to the latch side of a manually operated door as 300 mm. However, BS 8300 states: “Increasing this space to 450 mm will improve manoeuvrability, reduce the risk of wheelchairs colliding with the wall, and speed up completion of the task.”

This view is supported by this guidance, which recommends 450 mm as a minimum clear width to the latch side of the door, to allow for less experienced users, with a preference for 600 mm.

Doors opening into corridors

Approved Document M states: “Corridors and passageways will satisfy Requirement M1 or M2 if: . . . (g) any door opening towards a corridor, which is a major access route or an escape route, [is] recessed so that, when fully open, it does not project into the corridor space, except where the doors are to minor utility facilities, such as small store rooms and locked duct cupboards; (h) any door from a unisex wheelchair-accessible toilet projects when open into a corridor that is not a major access route or an escape route, provided the corridor is at least 1800 mm wide at that point.” However, this guidance recommends that non-recessed outward-opening doors (other than doors to locked service cupboards) are not allowed on any corridor in patient areas in healthcare premises based on a sensory impairment risk assessment.

Appendix 3 – References

Statutory/other requirements

The Equality Act 2010 and the Equality Act 2010 (Disability) Regulations 2010.

The Building Regulations 2010 (SI 2010/2214).
The Building (Amendment) Regulations 2011 (SI 2011/1515) came into force on 15 July 2011 and should be read in conjunction with The Building Regulations 2010.

Approved Document M (2013).

BS 8300:2009+A1:2010.

BS 5655-6:2011.

BS EN 81-70:2003 – ‘Safety rules for the construction and installation of lifts’.

BS ISO 4190-1:2010 – ‘Lift installation’.

BS 7036-1:1996. Code of practice for safety at powered doors for pedestrian use. General.

BS 7036-2:1996. Code of practice for safety at powered doors for pedestrian use. Straight and curved sliding doors and prismatic and folding doors.

BS 7036-3:1996. Code of practice for safety at powered doors for pedestrian use. Swing doors and balanced doors.

BS 7036-4:1996. Code of practice for safety at powered doors for pedestrian use. Low energy swing doors.

BS 7036-5:1996. Code of practice for safety at powered doors for pedestrian use. Revolving doors.

BS 7036:1988. Code of practice for provision and installation of safety devices for automatic power operated pedestrian door systems.

DH Estates and Facilities Policy Division publications

Health Building Note 00-01 – ‘General design principles’.

Health Building Note 00-02 – ‘Sanitary spaces’.

Health Building Note 00-03 – ‘Clinical and clinical support spaces’.

Health Building Note 00-10 Part A – ‘Flooring’.

Health Building Note 00-10 Part B – ‘Walls and ceilings’.

Health Building Note 00-10 Part C – ‘Sanitary assemblies’.

Health Technical Memorandum 05-02 – ‘Guidance in support of functional provisions for healthcare premises’ (DH 2007).

Health Technical Memorandum 05-03 Part E – ‘Escape lifts in healthcare premises’ (DH 2006).

Health Technical Memorandum 08-02 – ‘Lifts’ (DH 2010).

‘The Healthcare Cleaning Manual’ (DH 2009).

‘Wayfinding: effective wayfinding and signing systems guidance for healthcare facilities’ (DH 2005).

Department of Trade and Industry publications

ADULTDATA – The handbook of adult anthropometric and strength measurements (1998).

Other

T21027: Dulux Trade Colour & Contrast CD.

‘Building sight’ (RNIB 1995).

‘Colour, contrast and perception – Design guidance for internal built environments’. Project Rainbow, Bright, Cook and Harris (Reading University, 1997).

CIBSE Lighting Guide 02: Hospitals and Health Care Buildings (Society of Light and Lighting SLL LG2) 2008.

CIBSE Guide D – ‘Transportation systems in buildings’ (Chartered Institution of Building Services Engineers 2010).

‘Safer surfaces to walk on – reducing the risk of slipping’ (CIRIA 2006).

‘Lighting and colour for hospital design’ (Dalke et al 2004).

Appendix 4 – Additional ergonomic studies

Figure A1 Space for straight movement, visually-impaired person with stick

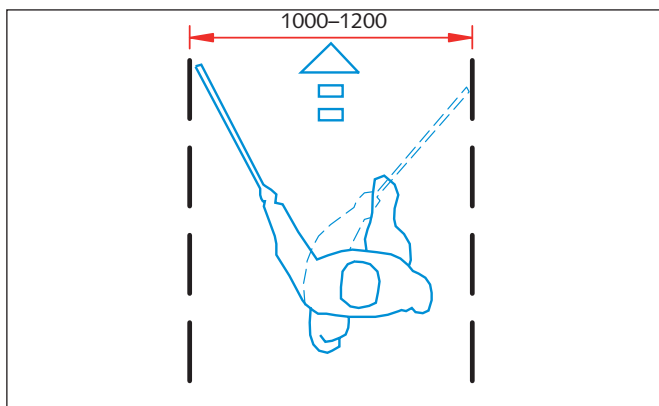

Figure A2 Space for straight movement, semi-ambulant person with frame and assistance

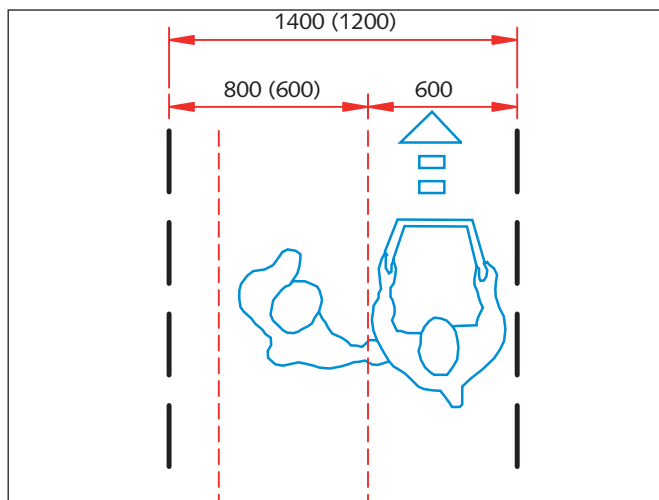

Figure A3 Mattress evacuation straight

